

Warner Electric

Twiflex

Braking Solutions for the Elevator Market



Power Transmission Solutions for the Elevator Market

WARNER ELECTRIC BRAKES FOR ELEVATOR APPLICATIONS

***YOUR JOURNEY WITH US IS MORE THAN JUST A BUSINESS PARTNERSHIP;
IT IS A CUSTOMER-CENTRIC EXPERIENCE.***

As one of the largest industrial brake and clutch manufacturers in the world, Warner Electric knows customers need quality products and timely delivery. That's why we're proud to be known for our:

- Proven and reliable technology
- Engineer-to-engineer collaboration
- Ability to manufacture worldwide
- Assembly line versatility
- Decades of experience
- Industry-leading testing lab
- Customized and standard solutions



From design and prototyping to testing and production, we believe in building a highly collaborative partnership with our customers.

- Quick prototype delivery with 3D printing options.
- Comprehensive live testing facilities to push the limits in hot, cold, dry, or wet environments.

Global customer service and account management teams are available at all time zones to offer the support you need. We comply with all major industry standards, including ISO, UL, and CSA.

With versatile global production capabilities, we can accommodate single-unit requirements or high-volume production. Count on us! Quality and care are at the core of everything we do.

**At Warner Electric, we provide solutions!
Visit our website at www.warnerelectric.com**

WARNER ELECTRIC INNOVATIONS FOR ELEVATOR BRAKES



QUIETLIFT™
Electrically Released Brake
Designed to offer a double braking system
Pages 3-4



WES
Contactless Warner Electric Sensor
Monitoring solution for elevator applications
Pages 5-6

THE WARNER ELECTRIC AND TWIFLEX FAMILY OF ELEVATOR BRAKES



ERS FENIX 08
Electrically Released Brake
To prevent ascending car overspeed and unintended movement
Pages 7-8



ERS VAR 15
Electrically Released Brake
Modular and redundant brake for gearless machines
Pages 17-18



ERS FENIX 09
Electrically Released Brake
Designed to offer a double braking system
Pages 9-10



ERS VAR 11-01
Electrically Released Brake
Modular and redundant brake for gearless machines
Pages 19-20



ERS FENIX 10
Electrically Released Brake
To prevent ascending car overspeed and unintended movement
Pages 11-12



ERS VAR 12
Electrically Released Brake
Modular and redundant brake for gearless machines
Pages 21-22



ERS VAR 07
Electrically Released Brake
Redundant brake for gearless machines
Pages 13-14



ERS VAR 14
Electrically Released Brake
To prevent ascending car overspeed for retrofit and modernization
Pages 23-24



W134
Friction Material
Advanced friction material technology for elevators
Pages 15-16



V-Series
Hydraulically Released Brakes
Caliper braking systems for high rise buildings and heavy duty escalators
Pages 25-26

QUIETLIFT™ BRAKE for the Elevator Market



Elevator Applications

- Gearless Motors

ELECTROMAGNETIC BRAKE FOR ELEVATORS



Spring-Applied Electromagnetic Brake

The QuietLift™ brake is a spring-applied electromagnetic brake, which operates in static and emergency braking. The QuietLift™ brake is designed to offer a double braking system. It is particularly suitable for gearless motors to meet Elevator standards EN81-20/50:2020.

The QuietLift™ brake is equipped with the Warner Electric Sensor (WES), which ensures reliable detection and offers a wear monitoring option. Featuring a steel-constructed innovative low-noise system, this brake ensures optimal performance throughout its lifespan. Additionally, the brake is designed to accommodate modular mounting positions and sizes for your project's requirements.

- Compact design
- Torque 125Nm - 700Nm
- Redundant brake circuits
- Single voltage as standard
- WES: Contactless sensor detection
- Silent operation <60 dB(A) (patent pending)
- Modular fixation (easy PCD adjustment)
- Duty cycle: 50% energized

www.warnerelectric.com

 **WARNER ELECTRIC™**
A REGAL REXNORD BRAND

QUIETLIFT™ BRAKE

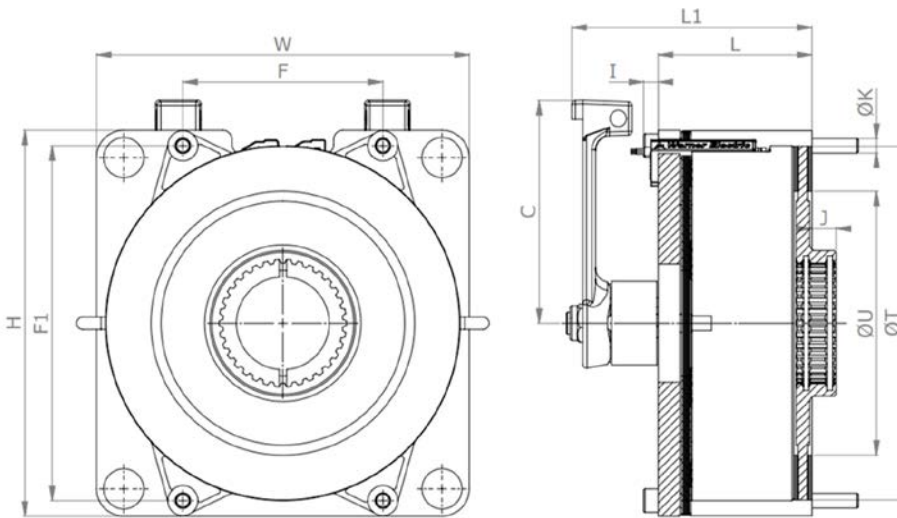

The QuietLift™ brake has been designed to propose compact squared dimensions and short length.

Dimensions defined below are preferred dimensions.

Further adaptation to your projects available on request.

Size		1	2	3	4	5
Standard Torque 2x	Nm	120 - 160	220 - 320	350 - 450	525 - 700	In progress
Cert. Max Speed	RPM (m/s)	1000 (8,9)	1000 (10,8)	900 (10,8)	800 (10,9)	
Power	W	63	68	82	82	
Weight	kg (HR)	16 (17)	28 (29)	36 (37)	43 (44)	
Splines Dimensions	DIN5480	N60 x 2,5 x 22 or N65 x 3 x 20	N65 x 3 x 20 or N70 x 2 x 34	N65 x 3 x 20 or N70 x 2 x 34	N70 x 2 x 34	
Hub Bore Max	mm	Ø45	Ø50	Ø50	Ø50	
W	mm	205	295	295	315	
H	mm	212	240	275	315	
L	mm	90,5	96,5	96,5	96,5	
L1	mm	138	144	144	144	
C	mm	125	125	125	125	
F	mm	110	264	272	237	
F1	mm	195	90	120	258	
I	mm	8	8	10	10	
J	mm	13	13	13	13	
ØK	mm	4xM8	4xM8	4xM10	4xM10	
ØU	mm	145	200	210	250	
ØT	mm	190	231,5	258	290	

WES for the Elevator Market



Elevator Applications

- Gearless Motors
- Gear Motors

CONTACTLESS MONITORING SOLUTION FOR ELEVATORS

Warner Electric Sensor (WES)

The WES is a contactless monitoring solution, providing reliable detection of the smallest strokes, especially on spring applied brakes with noise damping systems. With no sensitive mechanical parts, it outmatches the electromechanical solutions by far regarding functional safety and lifecycle expectancy.

The WES features a temperature compensated sensor able to operate from -40°C up to 105°C . It offers 4 types of outputs. An NPN type (Version 1) with an integrated pull-up resistor that simplifies the integration in almost all PLC based installations, a highly isolated SSR relay type NC and NO outputs (Version 2 and 4) that provides backward compatibility with almost all dry contact switches of the market, and an optional analog ratiometric output (Version 3) which offers a real time wear detection that measures the brake air gap.

- Compact design
- Accurate sensing :
Hysteresis $< 0.05\text{ mm}$ over the full range of temperature
- No “relaxation” areas are needed
- NPN output (integrated pull-up resistor)
- Backward compatible with NO/NC mechanical microswitches
- Analog output for wear sensor
- Operating temperature -40°C to 105°C



www.warnerelectric.com

WARNER ELECTRIC
A REGAL REYNOLD BRAND

WES

VERSION 1

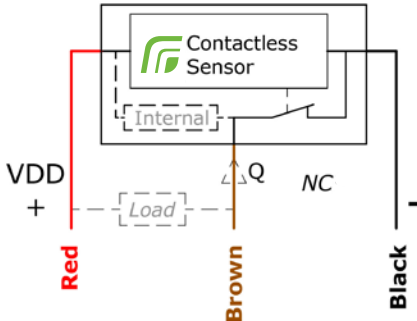

State Detection - NC

NPN Output (Sink) - 3 wires

Parameter	Symbol	Values			Note/Conditions
		Min	Typ	Max	
Supply Voltage	VDD	4 VDC	24 VDC	30 VDC	Reverse Voltage Protected
Supply Current				10 mA	
Operating Temperature		-40 °C		105 °C	
Output Voltage	Q	0.5 VDC	24 VDC	30 VDC	
Output Current	Q	< 1mA		30 mA	DC Current ESD protection to IEC 61000-4-2, level 4
Output Saturation Voltage				0.6 V	
Output Fall Time		50 μs			Depending on Load
Output Rise Time		50 μs			

VERSION 2

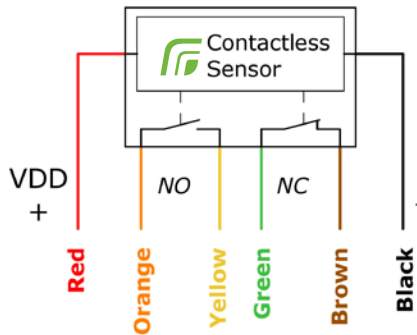

State Detection - NO/NC

SSR Outputs - 6 wires

Parameter	Symbol	Values			Note/Conditions
		Min	Typ	Max	
Supply Voltage	VDD	4 VDC	24 VDC	30 VDC	Reverse Voltage Protected
Supply Current	IDD			25 mA	
Operating Temperature		-40 °C		85 °C	
Output Voltage				60 VDC Peak	AC or DC allowed
Output LOAD Current				100 mA	AC or DC allowed
Output ON Resistance				16Ω	
Output OFF State					
Leakage Current				1 μA	
Output Fall Time				10 ms	VL = 10V
Output Rise Time				10 ms	

VERSION 3

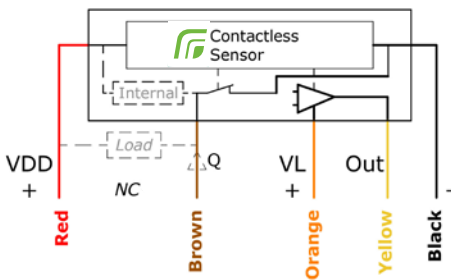

State Detection - NC + Brake Air Gap Measurement

NPN Output (Sink) - Analog Output - Ratiometric 5 VDC output - 5 wires

Parameter	Symbol	Values			Note/Conditions
		Min	Typ	Max	
Supply Voltage	VDD	4 VDC	24 VDC	30 VDC	Reverse Voltage Protected
Supply Voltage	VL	4.5 VDC	5 VDC	5.5 VDC	Reverse Voltage Protected
Supply Current				10 mA	
Operating Temperature		-40 °C		105 °C	
Output Voltage	Q	0.5 VDC	24 VDC	30 VDC	
Output Current	Q	< 1 mA		30 mA	DC Current ESD protection to IEC 61000-4-2, level 4
Output Voltage	Out	0.375 VDC	2.5 VDC	4.625 VDC	Out(Typ) = -S*Airgap(mm) + 2,5
Output Current	Out			1 mA	
Output Voltage Sensitivity	S	0.95 V/mm	1 V/mm	1.048 V/mm	

VERSION 4

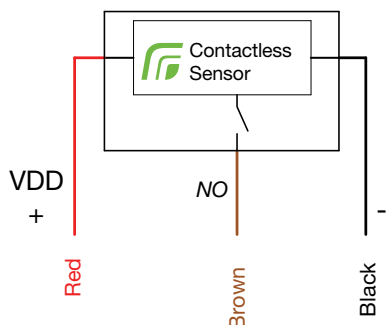

State Detection - NO

SSR Outputs - 3 wires

Parameter	Symbol	Values			Note/Conditions
		Min	Typ	Max	
Supply Voltage	VDD	4 VDC	24 VDC	30 VDC	Reverse Voltage Protected
Supply Current	IDD			25 mA	
Operating Temperature		-40 °C		85 °C	
Output Voltage				60 VDC Peak	AC or DC allowed
Output LOAD Current				100 mA	AC or DC allowed
Output ON Resistance				16Ω	
Output OFF State					
Leakage Current				1 μA	
Output Fall Time				10 ms	VL = 10V
Output Rise Time				10 ms	

ERS FENIX 08 for the Elevator Market



Elevator Applications

- Gearless Motors
- Gear Motors

ELECTRICALLY RELEASED BRAKE FOR ELEVATORS

Electrically Released Brake

The ERS FENIX 08 is an electrically released brake that is intended to prevent ascending car overspeed and unintended movement. The ERS FENIX 08 is suitable for new build gear motors to meet EN81-20&50 conformity.

- Complies with Directive 2014/33/EU
- Compact design with torque from 5Nm up to 2300Nm
- Single magnet and single friction disc
- Available with optional dustcover and hand release
- Low noise operation through the life of the brake
- Very easy installation
- Micro switch equipped
- Nearly maintenance free (further information in our service manual)
- Overexcitation (dual voltage) or single voltage

Customer drawing available on request

www.warnerelectric.com

WARNER ELECTRIC
A REGAL REYNOLD BRAND

ERS FENIX

Brake Configuration		Nominal Torque of Brake size / 100		Real Selling Torque of Brake	
08	1 Magnet & 1 Disc	0.05	5 Nm		06
09	2 Magnets & 2 Discs	0.10	10 Nm	10	1000 Nm
10	1 Magnet & 2 Discs	0.20	20 Nm	12	1200 Nm
		0.35	35 Nm	15	1500 Nm
		0.60	60 Nm	20	2000 Nm
		01	100 Nm	23	2300 Nm
		02	200 Nm	30	3000 Nm
		03	300 Nm	46	4600 Nm
		04	400 Nm		

Example of name: **ERS FENIX 08 10-1000**

(Brake with 1 magnets, 1 disc, nominal torque of size = 1000Nm, real torque of size = 1000Nm)

ERS FENIX 08

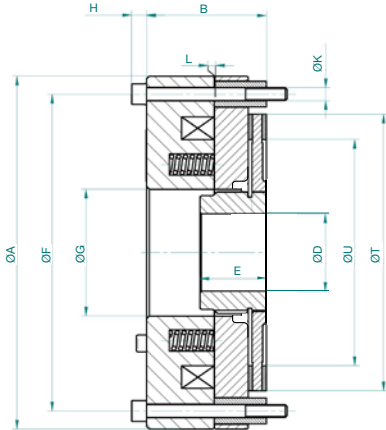

Voltage (VDC)

With Overexcitation		Without Overexcitation
Holding Voltage	Overexcitation Voltage	Single Voltage
24	48	24
52	103.5	103.5
103.5	207	207
ED=50%		

Size		01	02	03	06	10	15	23							
High Speed High Energy	Nm	70	130	150	250	200	400	575	800	900	1350	1500	2000	1700	2500
Cert. Max Speed	RPM	3000	1200	2800	1000	2200	800	1900	600	1500	500	1400	400	1200	400
A	mm	166	194	234	274	332	365	395							
B	mm	75	81	78	98	91	113	125							
D Standard H7	mm	Can vary depending on customer specifications													
E	mm	Can vary depending on customer specifications													
F	mm	145	170	214	250	303	330	360							
G	mm	59	70	80	98	145	145	188							
H	mm	9.4	9.4	9.4	13.1	13.1	17.3	17.3							
K	-	3xM8	3xM8	6xM8	3xM12	4xM12	4xM16	4xM16							
T	mm	125	150	194	222	275	296	325							
U	mm	90	116	145	175	230	230	210							
Hand- Release	-	OPTION													
Weight	Kg	10	14	21	34	41	69	85							

Size		0.05	0.10	0.20	0.35	0.60					
High Speed High Energy	Nm	5	7.5	10	15	20	30	35	50	60	75
Cert. Max Speed	RPM	5000	2000	5000	2000	4600	1700	4000	1500	3500	1200
A	mm	86	98	133	153	164					
B	mm	53	54	52	52	60					
C	mm	3.2	3.2	6	6	6					
D	mm	Can vary depending on customer specifications									
E	mm	Can vary depending on customer specifications									
F	mm	72	90	112	132	145					
G	mm	26	31	43.5	51	52					
ØK	mm	3xM4	3xM5	3xM5	3xM6	3xM8					
AA	mm	86	98	133	153	164					
T	mm	60	77	96	116	125					
U	mm	48	60	68	80	90.5					
Hand release	-	OPTION									
Weight	Kg	1.7	2	4	5.4	6.7					

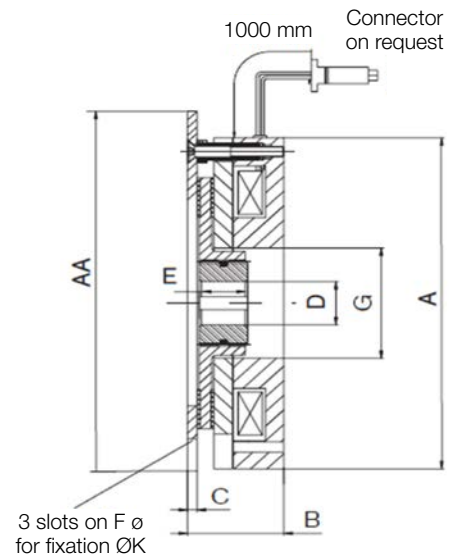

ERS FENIX 09 for the Elevator Market



Elevator Applications

- Gearless Motors
- Gear Motors

ELECTRICALLY RELEASED BRAKE FOR ELEVATORS

Electrically Released Safety Brake

The ERS FENIX 09 is an electrically released safety brake that operates in static and emergency stops that is designed to offer a double braking system. The ERS FENIX 09 is particularly suitable for gearless motors to meet EN81-20&50 conformity.

- Complies with Directive 2014/33/EU
- Standard torque capacity from 2x5Nm up to 2x2300Nm
- 2 magnets and 2 friction discs
- Available with optional dustcover and hand release
- Low noise operation through the life of the brake
- Very easy installation
- Micro switch equipped
- Nearly maintenance free (further information in our service manual)
- Overexcitation (dual voltage) or single voltage

www.warnerelectric.com

WARNER ELECTRIC
A REGAL REYNOLD BRAND

ERS FENIX

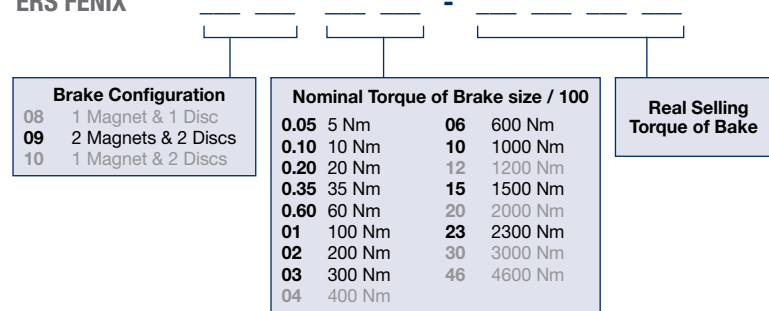

Example of name: **ERS FENIX 09 10-1000**

(Brake with 2 magnets, 2 disc, nominal torque of size = 1000Nm, real torque of size = 1000Nm)

ERS FENIX 09

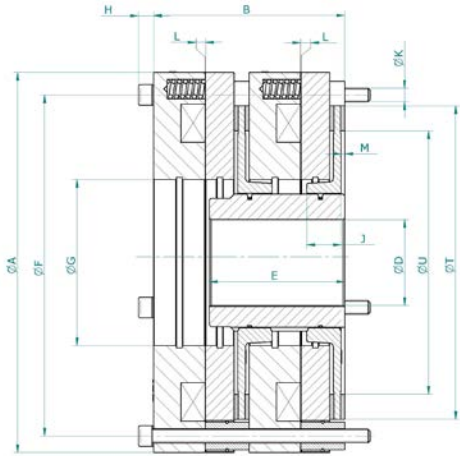

Voltage (VDC)

With Overexcitation		Without Overexcitation
Holding Voltage	Overexcitation Voltage	Single Voltage
24	48	24
52	103.5	103.5
103.5	207	207
ED=50%		

Size		01	02	03	06	10	15	23							
High Speed I High Energy	Nm	2x 70	2x 130	2x 150	2x 250	2x 200	2x 400	2x 575	2x 800	2x 900	2x 1350	2x 1500	2x 2000	2x 1700	2x 2500
Cert. Max Speed	RPM	3000	1200	2800	1000	2200	800	1300	600	1500	500	1400	400	1200	400
A	mm	166	194	234	274	332	365	395							
B	mm	151	162	156	196	182	226	250							
D Standard H7	mm	Can vary depending on customer specifications													
E	mm	Can vary depending on customer specifications													
F	mm	145	170	214	250	303	330	360							
G	mm	59	70	80	98	145	145	188							
H	mm	9.4	9.4	9.4	13.1	13.1	17.3	17.3							
J	mm	13	13	13	30	30	30	28.5							
K	-	3xM8	3xM8	6xM8	3xM12	4xM12	4xM16	4xM16							
T	mm	125	150	194	222	275	296	325							
U	mm	90	116	145	175	230	230	210							
Hand- Release	-	OPTION													
Weight	Kg	20	28	42	68	82	138	170							

Size		0.05	0.10	0.20	0.35	0.60					
High Speed I High Energy	Nm	5	7.5	10	15	20	30	35	50	60	75
Cert. Max Speed	RPM	5000	2000	5000	2000	4600	1700	4000	1500	3500	1200
A	mm	86	98	133	153	164					
B	mm	106	108	104	104	120					
C	mm	3.2	3.2	6	6	6					
D	mm	Can vary depending on customer specifications									
E	mm	Can vary depending on customer specifications									
F	mm	72	90	112	132	145					
G	mm	26	31	43.5	51	52					
ØK	mm	3xM4	3xM5	3xM5	3xM6	3xM8					
AA	mm	86	98	133	153	164					
T	mm	60	77	96	116	125					
U	mm	48	60	68	80	90.5					
Hand release	-	OPTION									
Weight	Kg	3.4	4	8	10.8	13.4					

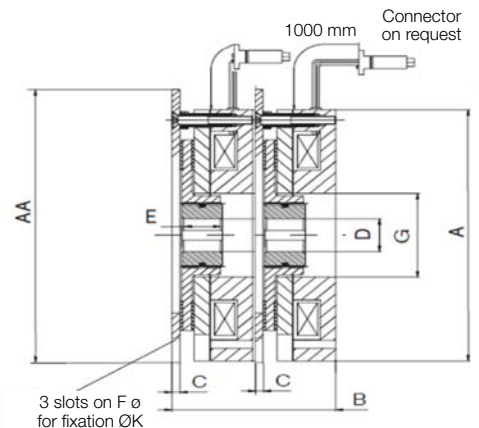

ERS FENIX 10 for the Elevator Market

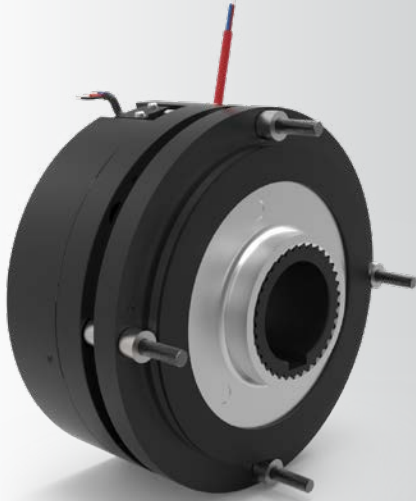

Elevator Applications

- Gearless Motors
- Gear Motors

ELECTRICALLY RELEASED BRAKE FOR ELEVATORS

Electrically Released Brake

The ERS FENIX 10 is an electrically released brake that is intended to prevent ascending car overspeed and unintended movement. The ERS FENIX 10 is suitable for new build gear motors to meet EN81-20&50 conformity.

- Complies with Directive 2014/33/EU
- Compact design with torque from 200Nm up to 4600Nm
- Single magnet and two friction disc
- Available with optional dustcover and hand release
- Low noise operation through the life of the brake
- Very easy installation
- Micro switch equipped
- Nearly maintenance free (further information in our service manual)
- Overexcitation (dual voltage) or single voltage

Customer drawing available on request

www.warnerelectric.com

WARNER ELECTRIC[™]
A REGAL REXNORD BRAND

ERS FENIX 10

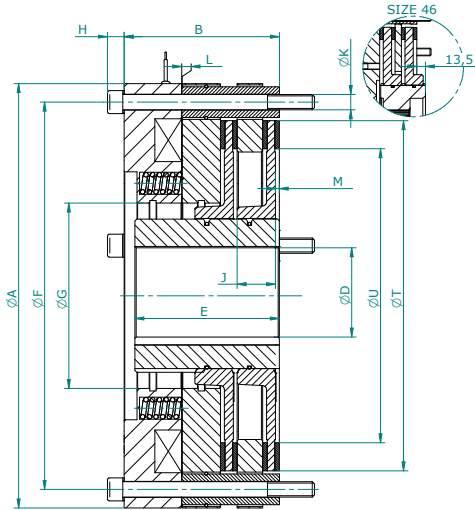

Voltage (VDC)

With Overexcitation		Without Overexcitation
Holding Voltage	Overexcitation Voltage	Single Voltage
24	48	24
52	103.5	103.5
103.5	207	207
ED=50%		

Size		02	04	06	12	20	30	46
High Speed High Energy	Nm	140 260 300	500	400 800	1150 1600	1800 2700	3000 4000	3400 5000
Cert. Max Speed	RPM	2600 1200 2800	1000	2200 800	1900 600	1500 500	1400 400	1200 400
A	mm	166	194	234	274	332	365	395
B	mm	98	103	109	124	121	151	170
D Standard H7	mm	Can vary depending on customer specifications						
E	mm	Can vary depending on customer specifications						
F	mm	145	170	214	250	303	330	360
G	mm	59	70	80	98	145	145	188
H	mm	9.4	9.4	9.4	13.1	13.1	17.3	17.3
J	mm	16	13	13	30	30	30	28.5
K	mm	3xM8	3xM8	6xM8	3xM12	4xM12	4xM16	4xM16
L Nominal	mm	0.4	0.4	0.4	0.4	0.4	0.5	0.5
T	mm	125	150	194	222	275	296	325
U	-	90	116	145	175	230	230	210
Hand-Release	mm	OPTION						
Weight	kg	12	17.3	25.2	38	50	76	104

ERS FENIX

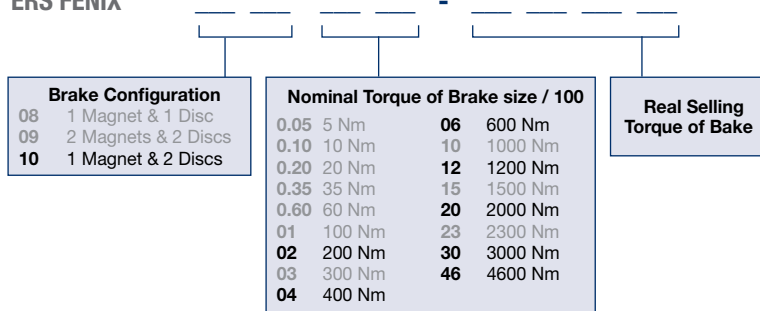

Example of name: **ERS FENIX 10 12-1200**
 (Brake with 1 magnets, 2 discs, nominal torque of size = 1200Nm, real torque of size = 1200Nm)

ERS VAR 07 for the Elevator Market



Elevator Applications

- Gearless Motors

ELECTRICALLY RELEASED BRAKE FOR ELEVATORS

Electrically Released Safety Brake

The ERS VAR 07, an electrically released safety brake that operates in static and emergency stops, is designed to offer a double braking system in a very compact dimension. The VAR 07 is particularly suitable for gearless motors with limited space

- Redundant system in accordance with EN 81-20/50
- Complies with Directive 2014/33/EU
- Extremely compact, round design
- Compact design with torque from 300Nm up to 900Nm
- Optional hand-release, mountable by customer
- Available with optional dustcover
- 1 shell / 2 independent braking circuits / 1 disc
- Low noise operation through the life of the brake
- Very easy installation
- Micro switch equipped
- Nearly maintenance free (further information in our service manual)
- Overexcitation (dual voltage) or single voltage

Customer drawing available on request

www.warnerelectric.com

WARNER ELECTRIC™
A REGAL REYNOLD BRAND

ERS VAR 07

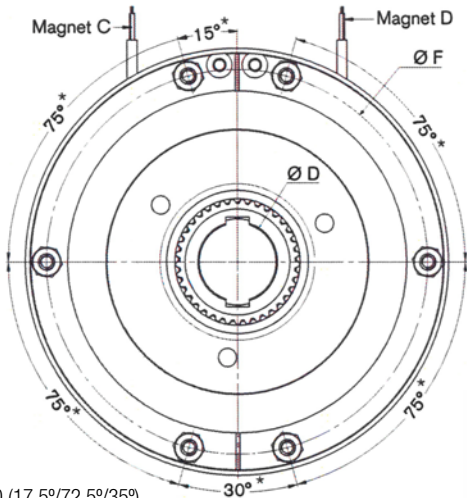

*SZ100 (17,5°/72,5°/35°)

*SZ300 (15°/75°/82.5°/15°/82.5°/75°)
*SZ500 (15°/57°/100.5°/15°/64.5°/93°)

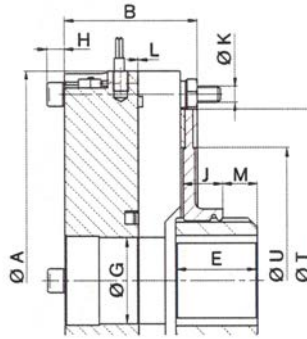

Voltage (VDC)

With Overexcitation		Without Overexcitation
Holding Voltage	Overexcitation Voltage	Single Voltage
24	48	24
52	103.5	103.5
103.5	207	207
ED=50%		

Size		300		420		600		800	
Standard Torque	Nm	2x315	2x350	2x350	2x450	2x500	2x600	2x800	2x900
Cert. Max Speed	RPM	600	300	600	300	600	300	500	300
A	mm	254		273		303		315	
B	mm	79		86		95		101	
D Standard H7	mm	Can vary depending on customer specifications							
E	mm								
M	mm								
F	mm	236		255		275		288	
G	mm	65		65		65		65	
H	mm	9.4		9.4		11.6		13.1	
J	mm	34		25		30		32.5	
K	-	6xM8		6xM8		6xM10		6xM12	
L Nominal	mm	0.4		0.4		0.4		0.4	
T	mm	210		233		243		258	
U	mm	175		190		200		200	
Hand- Release	-	OPTION							
Weight	Kg	25		32		42		54	
Inertia	kgcm								
Connection	-	On Request							

W134 for the Elevator Market

FRICITION MATERIAL FOR ELEVATORS

Advanced Friction Material Technology

The Warner Electric engineering team drew on its extensive brake technology knowledge, combined with vast elevator application experience, to develop the new W134 friction material.

The addition to the Warner Electric friction material family is designed to maintain consistent torque during both static braking and dynamic braking over a large range of rotation speeds with no torque overshoot at braking engagement. Consistent torque stability is also maintained in extreme temperatures and other challenging environmental conditions.

The W134 friction material is suitable for use in all elevator technologies, including belt-driven systems where torque stability is a critical concern.

The friction material was put through a rigorous battery of in-house testing to ensure that it's best-in-class performance is well-suited for a wide range of electrified powertrain applications.

	Current Lining	Friction W134
Energy per disc	57 kJ max	190 kJ
Max speed	900 rpm	1300 rpm
Max torque < 160%	100% adjusted brake	No adjustment
Holding torque	-10% / -15%	None
Climate	10% impact	None
Day + 1	Stability Recheck Warner	None

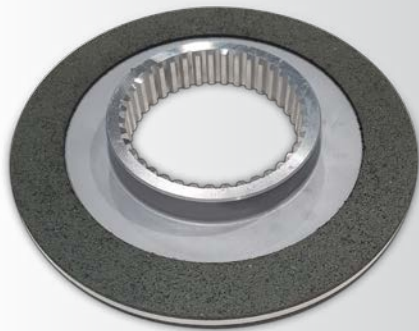

Elevator Applications

- Gearless Motors
- Gear Motors

www.warnerelectric.com

WARNER ELECTRIC
A REGAL REYNOLD BRAND

W134

- Superior torque stability during both static braking and dynamic braking
- Torque stability is maintained in extreme temperatures and other challenging environmental conditions
- Suitable for all elevator technologies, including belt-driven systems where torque stability is critical
- 100% organic-based, non-metallic add-ons
- Excellent energy dissipation

Dynamic torque 1600 Nm - 1300 rpm - 141 kJ

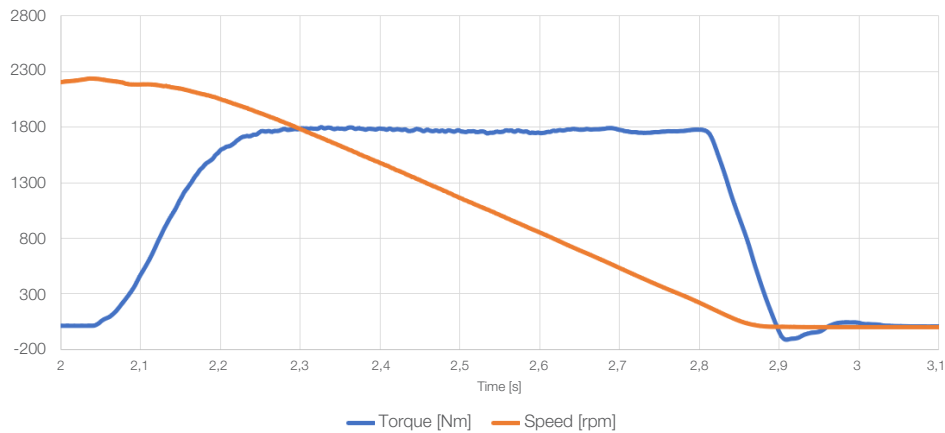

Dynamic braking

141 kJ

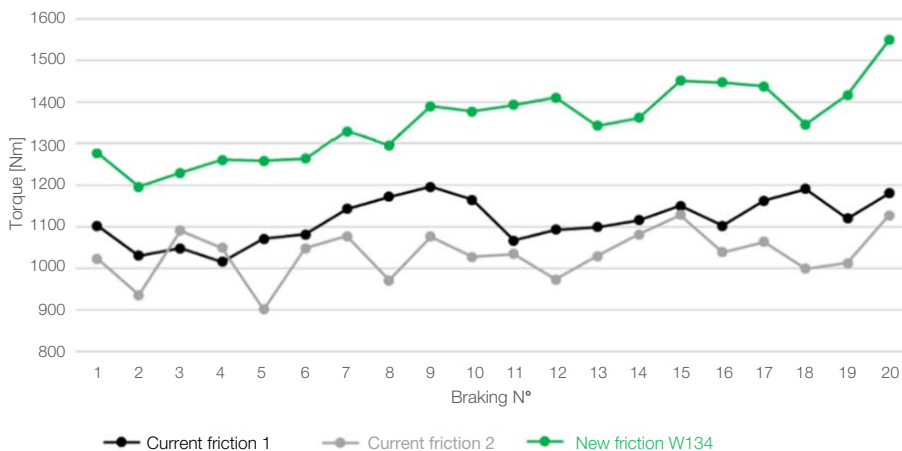

ERS VAR 15 for the Elevator Market



Elevator Applications

- Gearless Motors

ELECTRICALLY RELEASED BRAKE FOR ELEVATORS

Electrically Released Safety Brake

The ERS VAR 15, an electrically released safety brake with fixed magnets and a floating friction disc, is a highly modular braking system for gearless motors.

- Redundant system in accordance with EN 81-20/50 when two or more magnets are used
- Complies with Directive 2014/33/EU
- Compact and modular design: From 2 up to 4 magnets in standard configuration
- Torque Capacity in accordance with diameter of friction disc and number of magnets
- Available with optional hand release
- Low noise operation through the life of the brake
- Very easy installation
- Install directly on the drive housing or additional flange
- Micro switch equipped
- Nearly maintenance free (further information in our service manual)
- Overexcitation (dual voltage) or single voltage

www.warnerelectric.com

WARNER ELECTRIC[™]
A REGAL REXNORD BRAND

ERS VAR 15

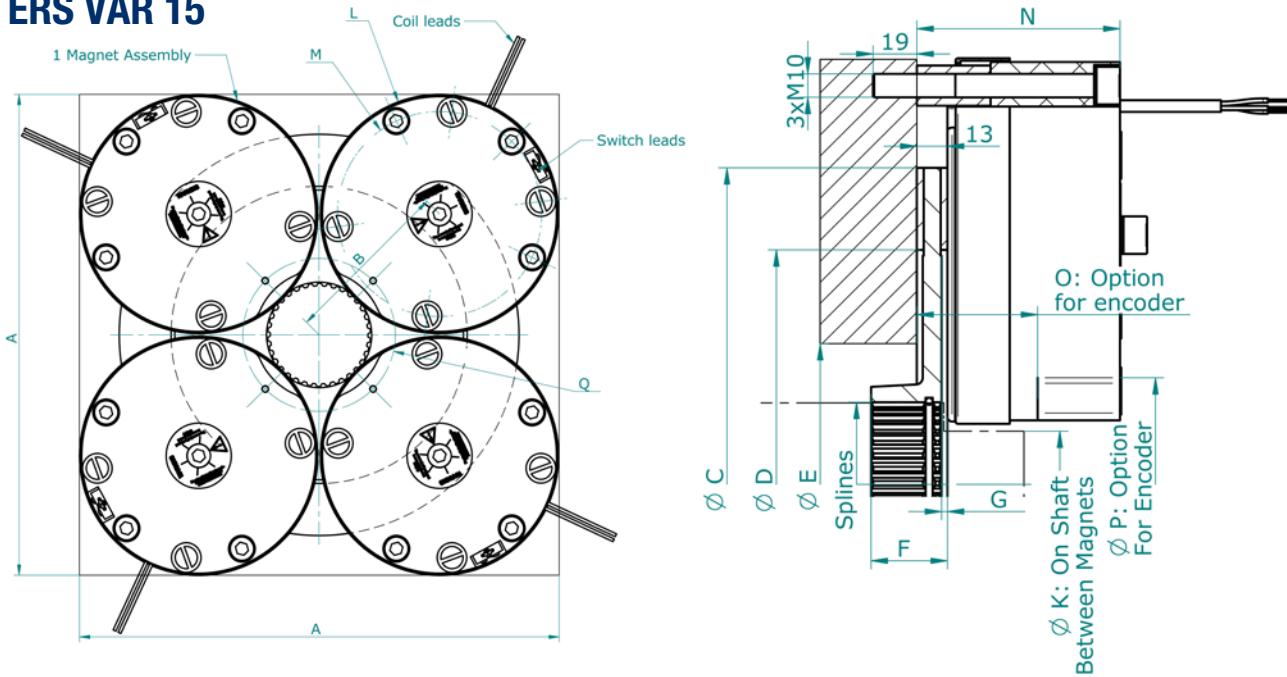

Characteristics for 1 Magnet Assembly

Size		ERS VAR15-02				ERS VAR15-11			
Friction Disc Ø	mm	237	270	237	270	237	270	237	270
Standard Torque Per Magnet	Nm	250	320	300	350	300**	400**	350	500
Cert. Max. Speed	m/s	6.5	3.25	6.5	3.25	6.15	3.69	6.15	3.69
Cert. Max. Speed	rpm	600	300	500	250	500	300	500	300
A	mm	290	305	292	324				
B	mm	103	112	93	115				
C	mm	237	270	237	270				
D	mm	177	200	177	200				
E _{min}	mm	100	100	100	100				
F	mm	30	30	30	30				
G	mm	3	3	3	3				
K	mm	59	78	25	69				
L Nominal	mm		143		161				
M	mm		124		138				
N	mm	101	101	86	86				
O (*)	mm	40	40	51	51				
P (*)	mm	83	105	50	90				
Q (*)	-	90	108	59	103				
Hand Release	-	Option							
Weight	Kg	10				11			

Voltage (VDC)

With Overexcitation	
Holding Voltage	Overexcitation Voltage
103.5	207
Without Overexcitation	
Single Voltage	
207	
103.5	
24	

Tolerances on the supply voltage at the brake terminals +5% / -10% (NF C 79-300).

(*) Option For Encoder

(**) 2 Magnets Maximum

ERS VAR 11-01 for the Elevator Market

ELECTRICALLY RELEASED BRAKE FOR ELEVATORS

Electrically Released Safety Brake Caliper

The VAR 11-01 is a highly modular braking system for modern elevators that is particularly suitable for flat gearless motors. The VAR 11-01 operates in static and/or emergency stops.

- Torque according to disc diameter and number of calipers
- Floating magnet and fixed disc
- Complies with Directive 2014/33/EU
- Hand release equipped
- Redundant capability according EN81-20/50 when two or more brakes are used
- Overexcitation (dual voltage)
- Microswitch equipped
- Very easy installation
- Nearly maintenance free (further information in our service manual)
- No airgap adjustment required

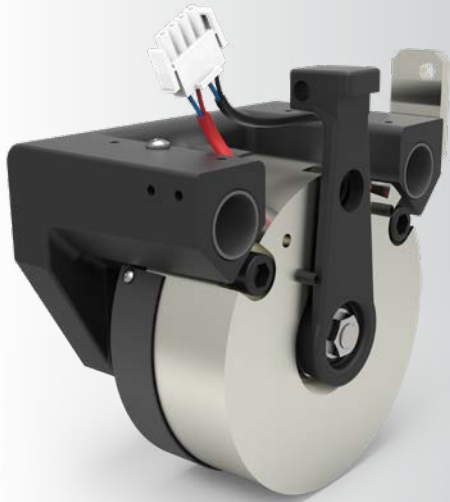

Elevator Applications

- Gearless Motors
- Gear Motors

www.warnerelectric.com

WARNER ELECTRIC™
A REGAL REYNOLD BRAND

ERS VAR 11-01

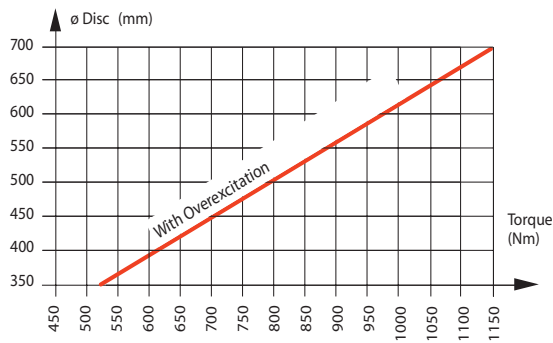
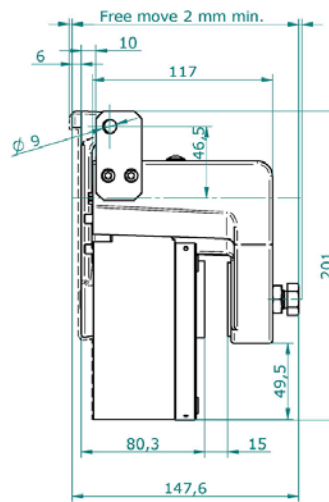
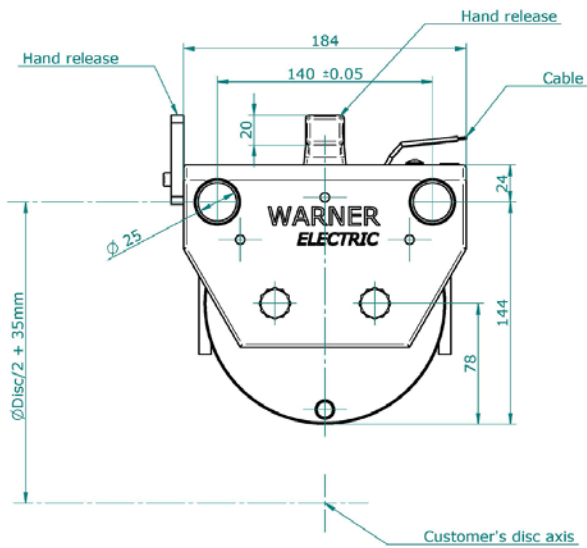

Linear speed (outer diameter of disc):
standard up to 15 m/s

Friction material: Steel or grey cast iron

Subject to alteration without prior notice.

Voltage (VDC)

With Overexcitation

Holding Voltage	Overexcitation Voltage
24	48
52	103.5
103.5	207
ED=50%	

Tolerances on the supply voltage at the brake terminals
+5% / -10% (NF C 79-300).

ERS VAR 12 for the Elevator Market



Elevator Applications

- Gearless Motors

ELECTRICALLY RELEASED BRAKE FOR ELEVATORS

Electrically Released Single Surface Brake

The VAR 12 is a highly modular braking system for modern elevators. With 2 brakes, the braking systems complies with EN81-20&50 and protects the elevator against ascending overspeed and unintended movement.

- Complies with Directive 2014/33/EU
- Torque capacity according to drum diameter
- Single voltage
- Hand release upon request
- Redundant capability according EN81-20/50 when two or more brakes are used
- Large braking torques can be achieved by using several brakes
- Very easy installation
- Nearly maintenance free (further information in our service manual)
- Microswitch equipped

www.warnerelectric.com

A REGAL REXNORD BRAND

ERS VAR 12

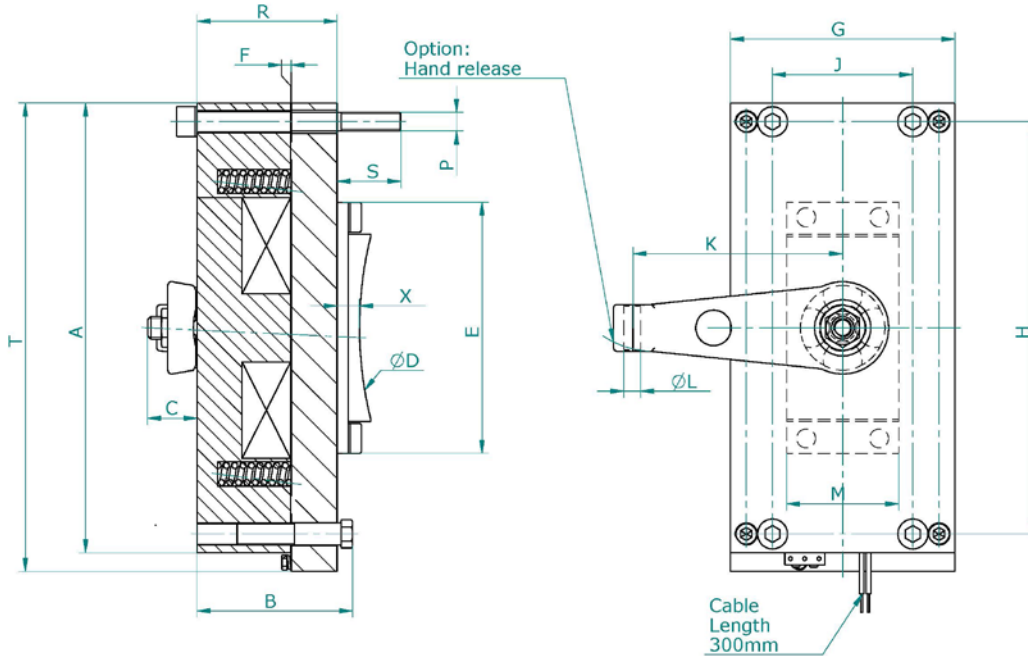

Tolerances on the supply voltage at the brake terminals =5% / -10% (NFC 79-300).

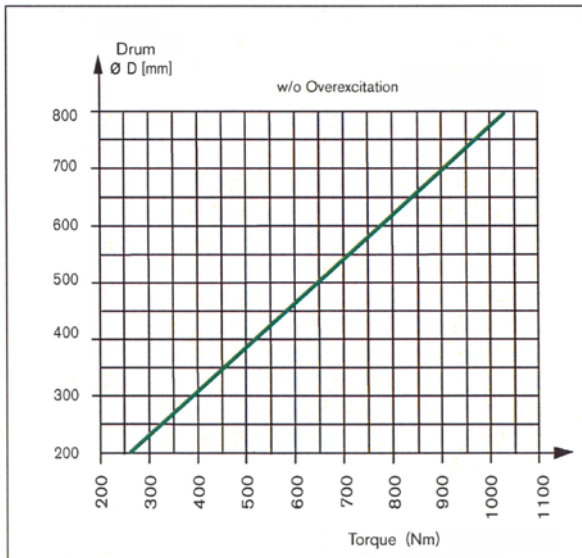

Linear speed (outer diameter of disc): standard up to 5 m/s
Friction material: Steel

Subject to alteration without prior notice.

VAR		12-03	12-04
A	mm	210	240
B	mm	93	83
C	mm	26	27
E	mm	100	134
F Nominal	mm	0,3	0,3
G	mm	120	120
H	mm	170	220
J	mm	85	75
K	mm	112,5	112,5
L	mm	9	9
M	mm	60	60
P	mm	4 X M10 X 1,5-6G	
R	mm	85	75
S	mm	25	35
T	mm	220	250
X	mm	8	12
Voltage*	VDC	24/207	24/207
ED	%	40	40
Weight	KG	16,5	16,8
Connection		Cable	Cable

Note: D has to be given by the customer.

*Single voltage

ERS VAR 14 for the Elevator Market



Elevator Applications

- Modernization

ELECTRICALLY RELEASED BRAKE FOR ELEVATORS

Sheave-Grip Modular Braking System

The VAR 14 electrically released brake is designed for modernization of gear motors and operates in static and emergency stops. It has been designed to prevent ascending car overspeed and unintended movement and complies with Section 2.19 ASME A.17.1 and EN81-20&50.

- Complies with Directive 2014/33/EU
- High modular braking system
- Standard braking force up to 6000 N
- Torque according to your sheave diameter
- Acting directly on traction sheave
- Basic configuration : 2 magnets
- Easy to install
- Microswitch equipped
- Nearly maintenance free (further information in our service manual)
- Overexcitation (dual voltage)

www.warnerelectric.com

WARNER ELECTRIC™
A REGAL REYNOLD BRAND

ERS VAR 14

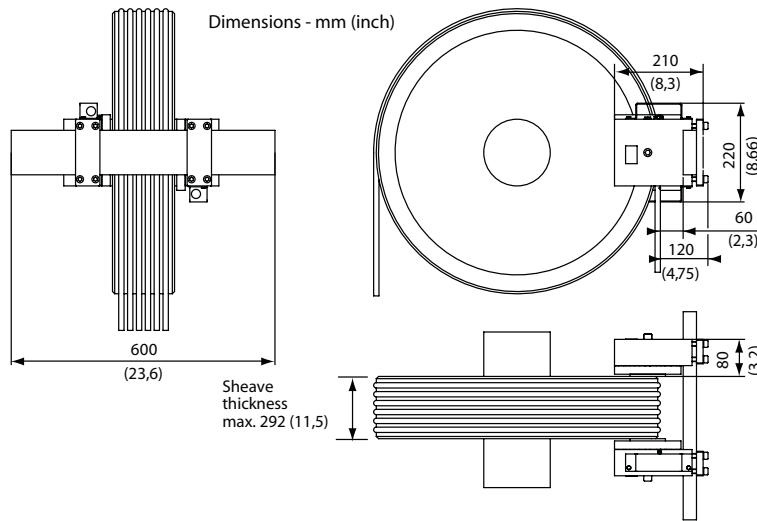

2 Magnets Silent				2 Magnets			
Model	ERS VAR 14-01-S			ERS VAR 14-01			
Part Number	1 12 106842	1 12 106843	1 12 106844	1 12 106847	1 12 106848	1 12 106849	1 12 106850
Braking Force (magnet A&B)	5000 N	4000 N	3000 N	6000 N	5200 N	4300 N	3500 N
OPTION: Electric connection on the CBC140-5 power supply / Serial connection of the 2 magnets – Part # 2 12 095515							
Nominal voltage	+5%/- 10%	230 VAC		Dependant on Application			
Nominal current	(holding)	2,2 A					
Overexcitation	(1,5 s)	4,4 A					
Power 20°C	(holding)	116 W					
Overexcitation	(1,5 s)	464 W					
OPTION: Electric connection on the CBC140-5 power supply / Parallel connection of the 2 magnets – Part # 2 12 095516							
Nominal voltage	+5%/- 10%	115 VAC		Dependant on Application			
Nominal current	(holding)	2,2 A					
Overexcitation	(1,5 s)	4,4 A					
Power 20°C	(holding)	116 W					
Overexcitation	(1,5 s)	464 W					
Electric connection directly on the magnets (data for 1 magnet)							
Nominal voltage	+5%/- 10%	52 VDC		52 VDC			
Overexcitation	(1,5 s)	103,5 VDC					
Nominal current	(holding)	1,1 A		1,1 A			
Overexcitation	(1,5 s)	2,2 A		4,5 A			
Power 20°C	(holding)	58 W		58 W			
Overexcitation	(1,5 s)	232 W					
ED		50%		100%			
Mass		31 kg (w/o connection rail)		31 kg (w/o connection rail)			
Airgap		0,4 mm		1 mm			
Temperature range	(ambient)	0°C to +40°C		0°C to +40°C			
Magnet insulation		Class F 155°C		Class F 155°C			
Maximum speed		5 m/s (outer sheave dia.)		5 m/s (outer sheave dia.)			
Switch voltage		24 VDC		24 VDC			
Switch current		10 - 100 mA		10 - 100 mA			

Subject to alteration without prior notice.

Twiflex V-Series Disc Brakes for the Elevator Market



Elevator Applications

- Modular Disc Brakes



HYDRAULICALLY RELEASED CALIPER BRAKES FOR ELEVATORS

Hydraulically Released Brakes

The Twiflex V-Series range of caliper braking systems are design for applications within high-rise/high-speed elevator drives and long-travel/mass-transit duty escalators.

- For passenger elevators, they protect against ascending overspeed and unintended movement
- For escalators, they ensure smooth deceleration in the event of power failure or other emergency stop event
- Braking force for spring applied units extends from 17 kN to 119, and beyond
- The modular designs accommodate all disc size options; greater braking torques achievable with multiple units
- Floating versions of each design minimize space-claim and accept large axial disc movements
- Standard and custom hydraulic power supply units available
- 'Soft braking' controllers enhance passenger comfort, achieving consistent deceleration rates regardless of load variation

VCS MK3

Caliper Type	Braking Force kN	Release Pressure bar	Minimum Pressure for Full Retraction bar	Air Gap in. (mm)
VCS62	62	127	159	.079 (2.0)
VCS50	50	101	135	.079 (2.0)
VCS47	47	95	110	.079 (2.0)
VCS41	41	84	99	.079 (2.0)
VCS33	33	68	78	.079 (2.0)
VCS30	30	62	76	.079 (2.0)
VCS23	23	46	54	.079 (2.0)
VCS17	17	35	43	.079 (2.0)

www.twiflex.com

TWIFLEX™
A REGAL REXNORD BRAND



VCSD

Caliper Type	Braking Force kN	Release Pressure bar	Minimum Pressure for Full Retraction bar	Air Gap in. (mm)
VCSD60	61	124	138	.079 (2.0)
VCSD50	46	94	100	.079 (2.0)
VCSD40	39	80	88	.079 (2.0)
VCSD30	29	59	65	.079 (2.0)
VCSD25	25	52	56	.079 (2.0)
VCSD20	21	44	49	.079 (2.0)
VCSD15	16	32	35	.079 (2.0)
VCSD10	11	22	24	.079 (2.0)

Hydraulically Released Brakes

Application

The V-Series (modular) disc brake range is designed for both static holding and dynamic (emergency) stopping duty. Braking force is applied by springs located in each module and released by hydraulic pressure. Depending on the individual brake model and rating selected a maximum braking force of 119kN can be achieved per brake unit. Should higher forces be needed, multiple calipers or larger units (VSD, VMS) may be used.

Description

Standard calipers comprising two spring modules are usually mounted each side of a supporting bracket. ‘Floating’ calipers comprising a single module and reactive half, may be introduced when the available space envelope is limited or to accommodate axial disc movement. Should high power dissipation be required, large-pad versions increase the units’ heat capacity. While the VCS brake’s unique compact design makes it more suited to static holding, both the VCSD and VKSD are specifically rated for high cyclic duty applications.

Special Features

- Modular construction for ease of installation and maintenance – no special tools required
- Industry-proven compact and rugged designs for reliable service
- Easily integrated with Twiflex HPU’s and ‘soft braking’ control systems
- Special finishes and custom designs on request
- Multiple status monitoring and wear sensor options

VKSD

Caliper Type	Braking Force kN	Release Pressure bar	Minimum Pressure for Full Retraction bar	Air Gap in. (mm)
VKSD119	119	124	138	.079 (2.0)
VKSD112	112	116	131	.079 (2.0)
VKSD104	104	108	124	.079 (2.0)
VKSD96	96	100	116	.079 (2.0)
VKSD88	88	92	108	.079 (2.0)
VKSD80	80	83	100	.079 (2.0)
VKSD71	71	75	92	.079 (2.0)
VKSD62	62	65	83	.079 (2.0)

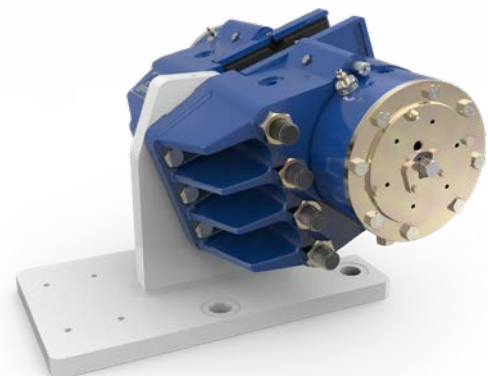

Warner Electric Facilities

North America

USA

31 Industrial Park Road
New Hartford, CT 06057 - USA
860-379-1252

*Electromagnetic Clutches
and Brakes*

449 Gardner Street
South Beloit, IL 61080 - USA
815-389-3771

4578 East Park 30 Drive
Columbia City, IN 46725 - USA
260-244-6183

*Precision Electric Coils and
Electromagnetic Clutches and
Brakes*

Customer Service
1-800-825-6544

Application Support
1-800-825-9050

Europe

France

7 rue de Champfleure - CS20095
49182 St Barthelemy d'Anjou - France
+33 (0)2 41 21 24 24

*Electromagnetic Clutches
and Brakes*

Customer Service
+33 (0)2 41 21 24 76

Application Support
+33 (0) 2 41 21 24 24

Asia Pacific

Australia

+61 2 9894 0133

China

+86 21 5169-9255

Hong Kong

+852 2615 9313

Singapore

+65 6487 4464

Taiwan

+886 2 2577 8156

Thailand

+66 2322 5527

Twiflex Facilities

Europe

United Kingdom

9 Briar Road, Twickenham
Middlesex TW2 6RB - England
+44 (0) 20 8894 1161
info@twiflex.com
sales@twiflex.com

Industrial Brake Systems

Amphill Road
Bedford, MK42 9RD - UK
+44 (0)1234 350311

Industrial Brake Systems

Germany

Hatschekstraße 36
69126 Heidelberg - Germany
+49 (0) 6221-304719
twiflex-sales@stieber.de

Industrial Brake Systems

North America

USA

2800 Fisher Road
Wichita Falls, TX 76302 - USA
940-723-3483
Toll free: 844-723-3483
twiflex.info@twiflex.com

Industrial Brake Systems

Asia Pacific

Australia

+61 2 9894 0133

China

+86 21 5169-9255

Hong Kong

+852 2615 9313

Singapore

+65 6487 4464

Taiwan

+886 2 2577 8156

Thailand

+66 2322 5527



Scan to see all
the brands of
Regal Rexnord

Neither the accuracy nor completeness of the information contained in this publication is guaranteed by the company and may be subject to change in its sole discretion. The operating and performance characteristics of these products may vary depending on the application, installation, operating conditions and environmental factors. The company's terms and conditions of sale can be viewed at <https://www.warnerelectric.com/company/terms-and-conditions>. These terms and conditions apply to any person who may buy, acquire or use a product referred to herein, including any person who buys from a licensed distributor of these branded products.

©2023 by Warner Electric LLC. All rights reserved. All trademarks in this publication are the sole and exclusive property of Warner Electric LLC or one of its affiliated companies.
©2023 by Twiflex LLC. All rights reserved. All trademarks in this publication are the sole and exclusive property of Twiflex LLC or one of its affiliated companies.



www.regalrexnord.com

Elevator Brakes

Warner Electric
1-815-389-3771
+33 (0) 2 41 21 24 24

Twiflex
1-844-723-3483
+44 (0) 20 8894 1161

P-1733-C 9/23