

## Built-In Freewheels

# NFR



### TYPE



Type NFR is a bearing supported roller type freewheel without any sealing. Lubrication and sealing must be provided by the installation. Standard lubrication is oil.

Size 8 to 20 units use steel on steel bearing support from the inner race. Above size 25, two 160.. series ball bearings are used, giving a higher overrunning speed capacity. A typical arrangement is shown overleaf.

The inner race is keyed to the shaft. The outer race has a positive n6 tolerance to give a press fit in a housing to H7. Additional side notches provide for positive torque transmission. The housing must be strong enough to not expand after assembly.

# Built-In Freewheels

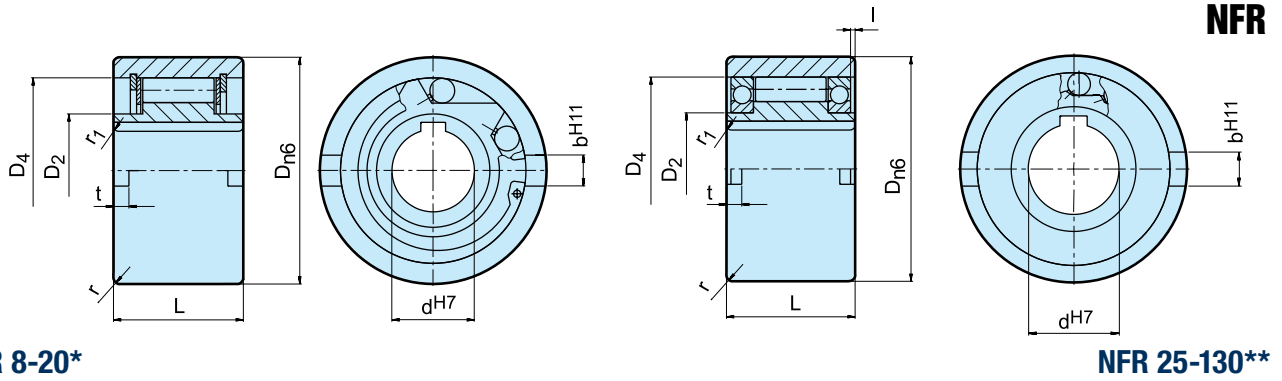

NFR 8-20\*

NFR 25-130\*\*

Type	Size	Overrunning speeds			Bearing										Weight
		$T_{KN}^{1)}$ [Nm]	$n_{imax}^{2)}$ [min <sup>-1</sup> ]	$n_{amax}^{3)}$ [min <sup>-1</sup> ]		$D_{n6}$ [mm]	$D_2$ [mm]	$D_4$ [mm]	$L$ [mm]	$I$ [mm]	$t$ [mm]	$b^{H11}$ [mm]	$r$ [mm]	$r_1$ [mm]	
NFR (ANR-ANG)	8	20	1000	1000	*	37	20	30	20		3	6	1	1,5	0,1
	12	20	1000	1000	*	37	20	30	20		3	6	1	1,5	0,1
	15	78	850	850	*	47	26	37	30		3,5	7	1,5	1,5	0,3
	20	188	650	650	*	62	37	52	36		3,5	8	2	2	0,6
	25	250	2100	3600	16008**	80	40	68	40	0,2	4	9	2,5	2	1,2
	30	500	1700	3200	16009**	90	45	75	48	0,2	5	12	2,5	2	1,8
	35	663	1550	3000	16010**	100	50	80	53	1,2	6	13	2,5	2,5	2,4
	40	1100	1150	2600	16011**	110	55	90	63	2,2	7	15	3	2,5	3,3
	45	1500	1000	2400	16012**	120	60	95	63	2,2	7	16	3	2,5	4,0
	50	2375	800	2150	16014**	130	70	110	80	2,7	8,5	17	3,5	3	5,7
	55	2550	750	2000	16015**	140	75	115	80	4,2	9	18	3,5	3	6,5
	60	4250	650	1900	16016**	150	80	125	95	3,2	9	18	3,5	3,5	8,9
	70	5875	550	1750	16018**	170	90	140	110	1,1	9	20	3,5	3,5	13,5
	80	10000	500	1600	16021**	190	105	160	125	0	9	20	4	3,5	19,0
	90	17250	450	1450	16024**	215	120	180	140	0,6	11,5	24	4	4	27,2
100	19625	350	1250	16028**	260	140	210	150	2,6	14,5	28	4	4	44,5	
130	34750	250	1000	16032**	300	160	240	180	2	17,5	32	5	5	68,0	

## NOTES

1)  $T_{max} = 2 \times T_{KN}$   
» Refer to Selection page 7 to 11

2) Inner race overruns

3) Outer race overruns

Keyway to DIN 6885.1

\*) With plain bearing steel on steel

\*\*) With 2 ball bearings series 160.

» Refer to mounting and maintenance instructions page 12 to 13

## MOUNTING EXAMPLE

