

## Centrifugally Lift Off Sprags Freewheels

# RSCI 180-300



### TYPE



Type RSCI is a centrifugal lift off sprag type freewheel with the inner race rotating. Only the inner race is designed for freewheeling.

Primarily designed as a backstop, this type can be also used as an overrunning clutch in crawl drives, where

the overrunning speed is high but the driving speed is low and does not exceed the maximum driving speed shown in the table. Centering of the outer race must use the inner bore. The centering spigot must not contact the sprag cage. Please refer to page 72 (RSCI 20-130) for further information.

# Centrifugally Lift Off Sprags Freewheels

RSCI 180-300

RSCI

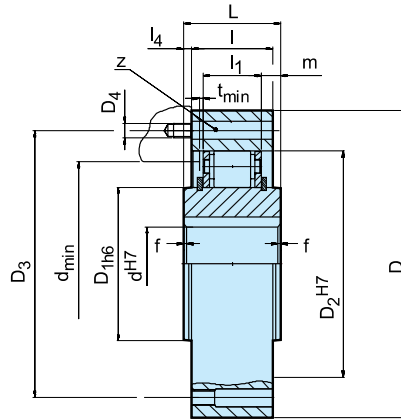

Type	Size	Torque	Speeds			Number										Weight				
	$d^{H7}$ [mm]	$T_{KN}^{1)}$ [Nm]	$n_{max}^{2)}$ [min <sup>-1</sup> ]	$n_{min}^{3)}$ [min <sup>-1</sup> ]	$n_{imax}^{4)}$ [min <sup>-1</sup> ]	$D^{5)}$ [mm]	$D_{1h6}$ [mm]	$D_2^{H7}$ [mm]	$D_3$ [mm]	$D_4$	$z$	$L$ [mm]	$l$ [mm]	$l_1$ [mm]	$l_4$ [mm]	$f \times 45^\circ$ [mm]	$d_{min}$ [mm]	$m$ [mm]	$t_{min}$ [mm]	[kg]
RSCI	180	31500	115	285	1300	412	240	310	360	M20	12	90	80	53	5	3,5	280	18,6	3	59
	180 M	50000	90	220	1300	422	240	310	370	M20	18	120	120	83	0	4	280	18,5	2	92
	180 II	63000	115	285	1300	412	240	310	360	M20	24	160	160	118	0	3,5	280	22	3	116
	180 II-M	100000	90	220	1300	425	240	310	370	M24	24	240	240	176	0	4	280	31	3	190
	220	42500	110	265	1100	470	290	360	410	M20	16	105	80	60	12,5	4	330	23,5	3	90
	220 M	68000	85	205	1100	480	290	360	410	M24	16	120	120	83	0	4	330	18,5	2	109
	220 II	85000	110	265	1100	480	290	360	430	M24	18	160	160	130	0	4	330	15	3	159
	220 II-M	136000	85	205	1100	490	290	360	425	M30	20	240	240	176	0	4	330	32	2	249
	240	52000	105	250	1100	500	320	390	440	M20	16	105	90	60	7,5	4	360	15	2	95
	240 M	83000	80	195	1100	520	320	390	440	M24	16	120	120	83	0	4	360	18,5	2	137
	240 II	104000	105	250	1100	520	320	390	440	M24	24	180	180	132	0	4	360	24	2	191
	240 II-M	166000	80	195	1100	530	320	390	455	M30	24	240	240	181	0	4	360	32	2	250
	260	65000	100	240	1000	550	360	430	500	M24	16	105	105	60	0	4	400	22,5	2	130
	260 M	100000	75	185	1000	580	360	430	500	M24	24	125	125	83	0	4	400	21	2	183
	260 II	130000	100	240	1000	580	360	430	500	M24	24	210	210	132	0	4	400	39	2	262
	260 II-M	200000	75	185	1000	580	360	430	500	M30	24	250	250	176	0	4	400	37	2	369
	300	78000	90	225	1000	630	410	480	560	M24	24	105	105	60	0	4	460	22,5	3	174
	300 M	125000	70	175	1000	630	410	480	560	M24	24	125	125	83	0	4	460	21	3	210
300 II	156000	90	225	1000	630	410	480	560	M24	24	210	210	134	0	4	460	38	3	351	
300 II-M	250000	70	175	1000	630	410	480	560	M30	24	250	250	182,6	0	4	460	33,7	3	457	

## NOTES

- $T_{max} = 2 \times T_{KN}$   
» Refer to Selection page 7 to 11
- This maximum allowable torque transmission speed  $n_{max}$  must not be exceeded when transmitting torque
- This minimum allowable overrunning speed  $n_{min}$  should not be reduced under continuous operation.  
Possible reduction of this minimum speed on request
- Inner race overruns  
Keyway to DIN 6885.1
- Tolerance +1

Cover F8 must be ordered separately  
» Refer to mounting and maintenance instructions page 12 to 13

Other bore diameters on request

## MOUNTING EXAMPLE

