

# SIME Brakes Industrial Braking Systems



# Stromag

Founded in 1932, Stromag has grown to become a globally recognized leader in the development and manufacture of innovative power transmission components for industrial drivetrain applications. Stromag engineers utilize the latest design technologies and materials to provide creative, energy-efficient solutions that meet their customer's most challenging requirements.

Stromag's extensive product range includes flexible couplings, disc brakes, limit switches, an array of hydraulically, pneumatically, and electrically actuated brakes, and a complete line of electric, hydraulic and pneumatic clutches.

Stromag engineered solutions improve drivetrain performance in a variety of key markets including energy, off-highway, metals, marine, transportation, printing, textiles, and material handling on applications such as wind turbines, conveyor systems, rolling mills, agriculture and construction machinery, municipal vehicles, forklifts, cranes, presses, deck winches, diesel engines, gensets and stage machinery.



VISIT US ON THE WEB AT [STROMAG.COM](http://STROMAG.COM)

# Altra Motion

Altra is a leading global designer and producer of a wide range of electromechanical power transmission and motion control components and systems. Providing the essential control of equipment speed, torque, positioning, and other functions, Altra products can be used in nearly any machine, process or application involving motion. From engine braking systems for heavy duty trucks to precision motors embedded in medical robots to brakes used on offshore wind turbines, Altra has been serving customers around the world for decades.

Altra's leading brands include **Ameridrives**, **Bauer** Gear Motor, **Bibby** Turboflex, **Boston** Gear, **Delevan**, **Delroyd** Worm Gear, **Deltran**, **Formsprag** Clutch, **Guardian** Couplings, **Huco**, **Jacobs** Vehicle Systems, **Kilian**, **Kollmorgen**, **Lamiflex** Couplings, **Marland** Clutch, **Matrix**, **Nuttall** Gear, **Portescap**, **Stieber**, **Stromag**, **Svendborg** Brakes, **TB Wood's**, **Thomson**, **Twiflex**, **Warner** Electric, **Warner** Linear and **Wichita** Clutch.

VISIT US ON THE WEB AT [ALTRAMOTION.COM](http://ALTRAMOTION.COM)



# SIME Brakes

## SECURITY - QUALITY - RELIABILITY

**With more than 60 years of experience, Stromag provide high efficiency braking systems to equip steel industries, nuclear plants, port cranes, offshore winches and mass transports throughout the world.**

Quality and innovation have always been the two essential features in the development of the company. Therefore Stromag provide disc brakes certified by recognized authorities such as DNV, ABS, TUV, Lloyd's Register and EDF.

In 2018, ISO 9001 certification of our Quality management system was renewed under the version V2015 and our Safety management system was awarded OHSAS 18001 - V2007 certification.

Whatever the application, Stromag meet the global supply requirements with standard or fully customised braking systems solutions.

## OUR KNOW-HOW AT YOUR DISPOSAL

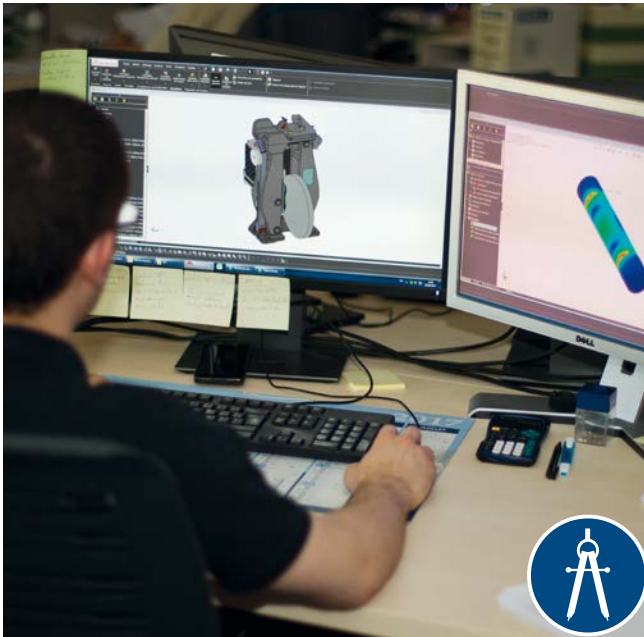

### RESEARCH & DEVELOPMENT DEPARTMENT

In a mutually beneficial way, Stromag create a strong relationship with their customers in order to understand their needs and provide them the best solution. With in-depth knowledge and experience in all key applications and markets, our teams keep constantly abreast of every changing needs and market development.



### TRAINING

After sales service team can provide to its customers training sessions : upgrade operations on-site or trainings in the production center in La Guerche (France). Each training consists of two parts : theoretical in a classroom / practical in the work-shop. Topics : products operation, periodic maintenance, settings, fault diagnosis.

### BENEFITS

- |  |  |
|--|--|
| <ul style="list-style-type: none"><li>• A team of experts at your disposal</li><li>• Reactivity of the interventions</li><li>• Study of the specific requirements</li><li>• Secured installation</li></ul> | <ul style="list-style-type: none"><li>• Optimal operation of the braking systems</li><li>• Preventive maintenance</li><li>• Expertise sustainability</li></ul> |
|--|--|

Reactivity, availability and listening at the customer are values which define our teams. We put all our experience and knowledge at your disposal:

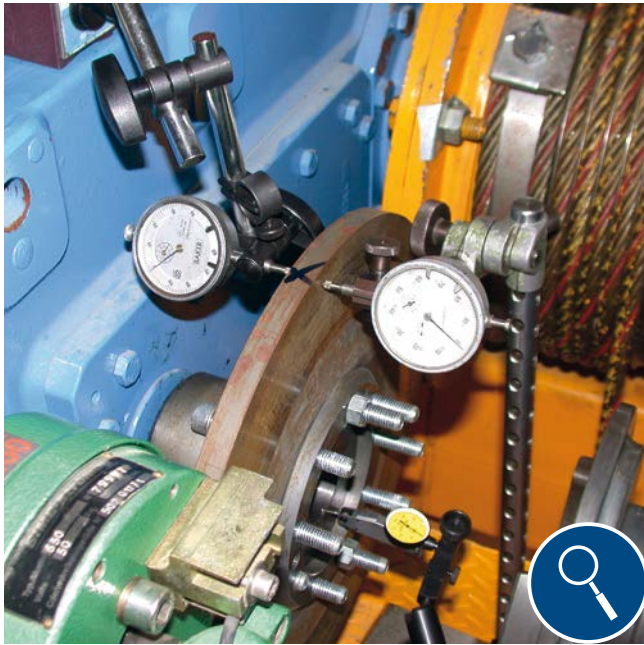

## DIAGNOSIS

The After Sales team shares its “know-how” with companies having an important fleet to help them to realise a self-diagnosis on their brakes systems to achieve their maximal reliability in compliance with the safety regulations. The diagnosis takes place in two stages : a complete on-site examination of the different devices and a detailed report with synthesis for a global visibility.



## INTERVENTION

Stromag has many sub-structures in France and worldwide ; these allow our After Sales Service Department to operate very fast in the customer sites. Each member of our team has a qualified engineering background which means they are totally able to help and advise customers technically and commercially.

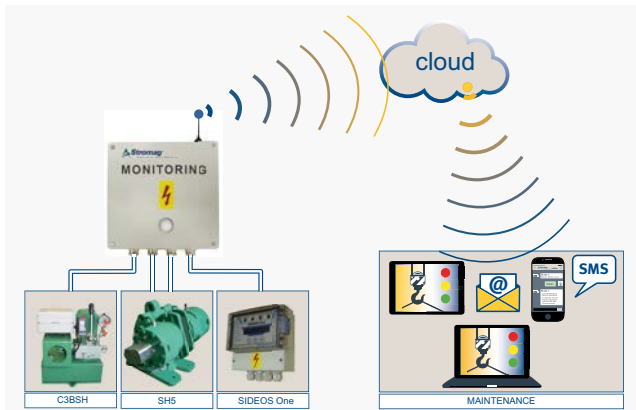

Stromag developed a Monitoring system which allows to connect your braking system to one or several monitoring modules.

CAN Bus enables an easy connection, transmission and processing of a great quantity of data.

The modules offer a high degree of adaptability and allow utilisation of transmission means as : SD cards, mobile telephone, internet.

## SIME Brakes PRODUCTS

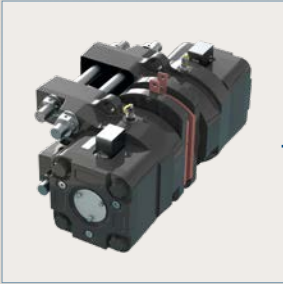

Hydraulic  
emergency brakes



Hydraulic  
Power Packs

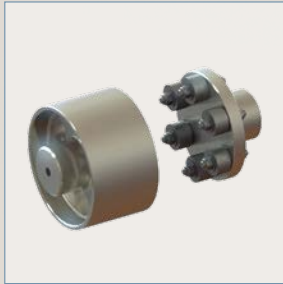
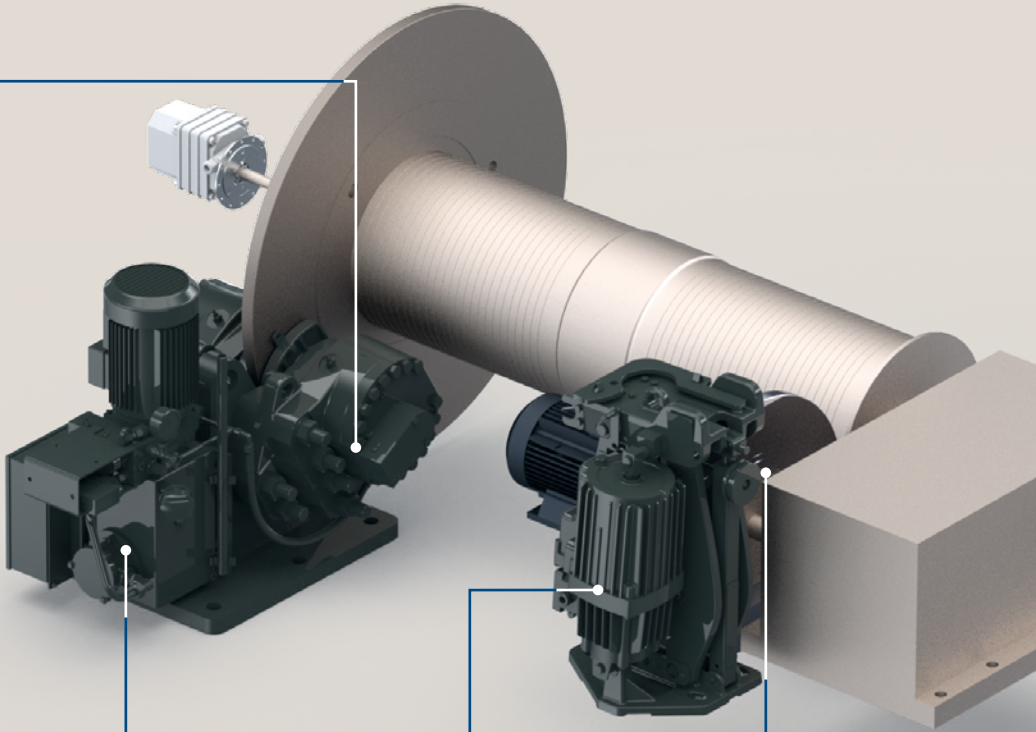

Drums &  
couplings



Drum brakes  
with thrustor



Disc brakes  
with thrustor

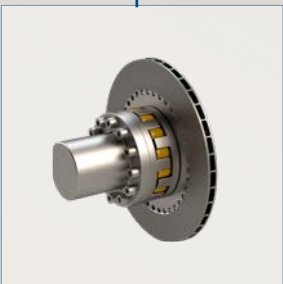

Discs &  
couplings

## COMPLETE BRAKING SOLUTIONS



Electrical  
power units



Electromagnetic  
emergency brakes



Safety systems

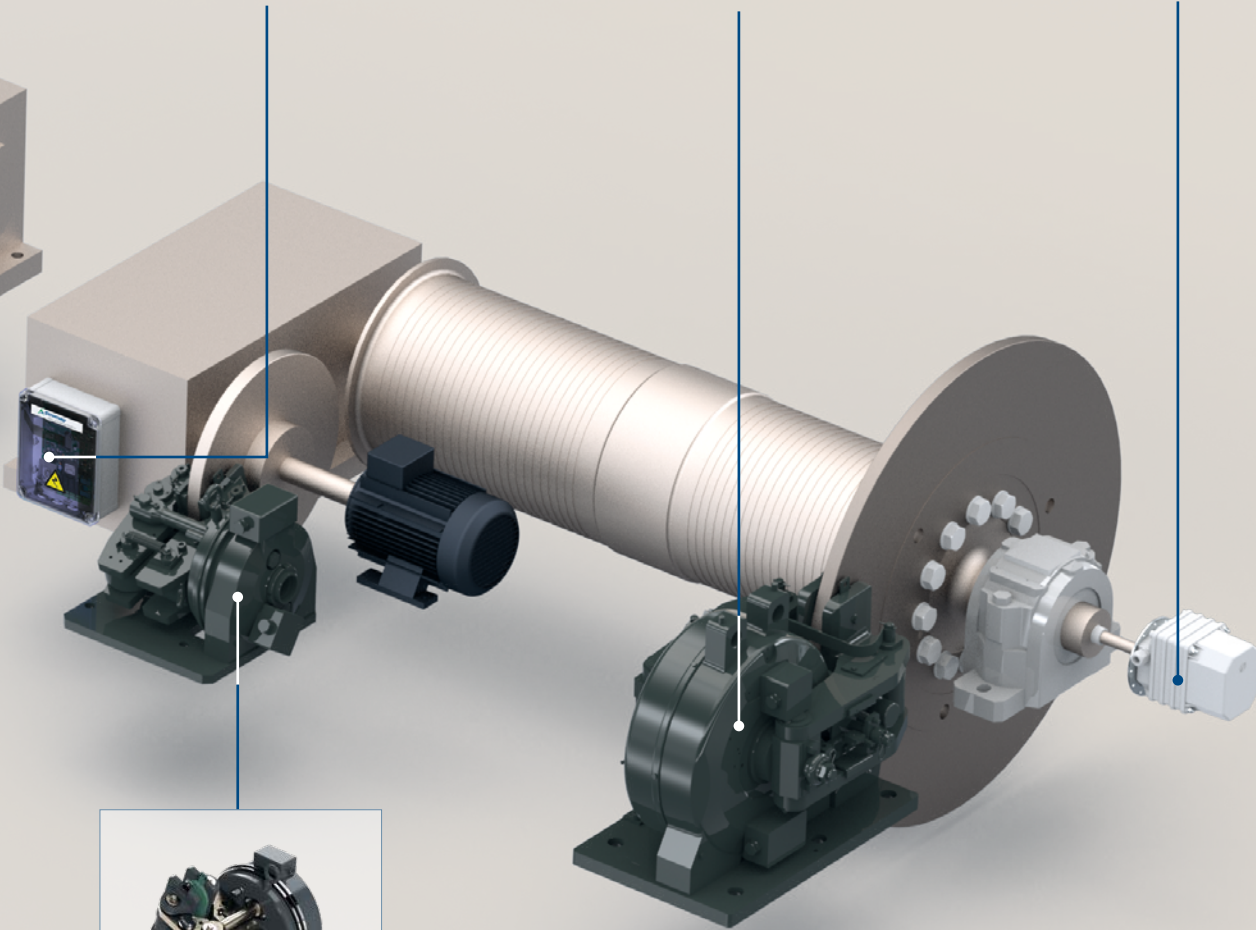

Electromagnetic  
service brakes

# SIME Brakes Industrial Braking Systems

## SOLUTIONS FOR YOUR APPLICATION

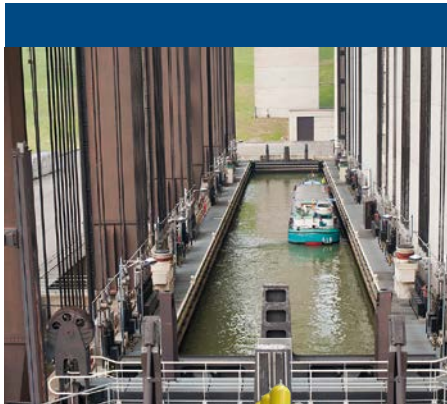

### Solutions for **BOAT LIFTING SYSTEMS**

- Hydraulic service brakes type SHD
- Hydraulic emergency brakes type SH
- Custom Hydraulic Power Packs
- Touch-screen and control interfaces
- CRD systems for regulated braking
- Tailor made solutions

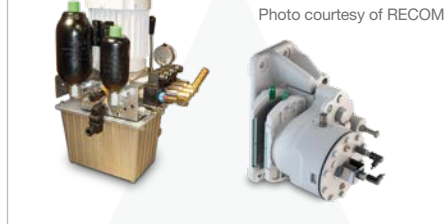

### Solutions for **CONSTRUCTION INDUSTRIES**

- Hydraulic brakes
- Electromagnetic brakes
- Thrustors brakes
- Drum brakes
- Discs & Couplings
- Hydraulic Power Packs
- Electrical units
- Safety and control systems



### Solutions for **PORTS**

- Hydraulic brakes
- Electromagnetic brakes
- Thrustors brakes
- Drum brakes
- Discs & Couplings
- Hydraulic Power Packs
- Electrical units
- Safety and control systems

## HIGH CUSTOMERS SATISFACTION

SIME Brakes products and services comply with the requirements of our customers in terms of quality, safety, service life, easy maintenance and delivery times. The quality and environmental policy is an integral part of our company policy.

The certification ISO9001 of our Quality management system is renewed under the version ISO 9001 - V2015 in 2018, combined with OHSAS 18001 - V2007 certification.

With more than 60 years of experience in the supply of high efficiency braking systems, Stromag provides disc brakes certified by recognised organisations such as DNV, ABS, TUV, Loyd's Register and EDF.





# SIME Brakes Industrial Braking Systems

## Content

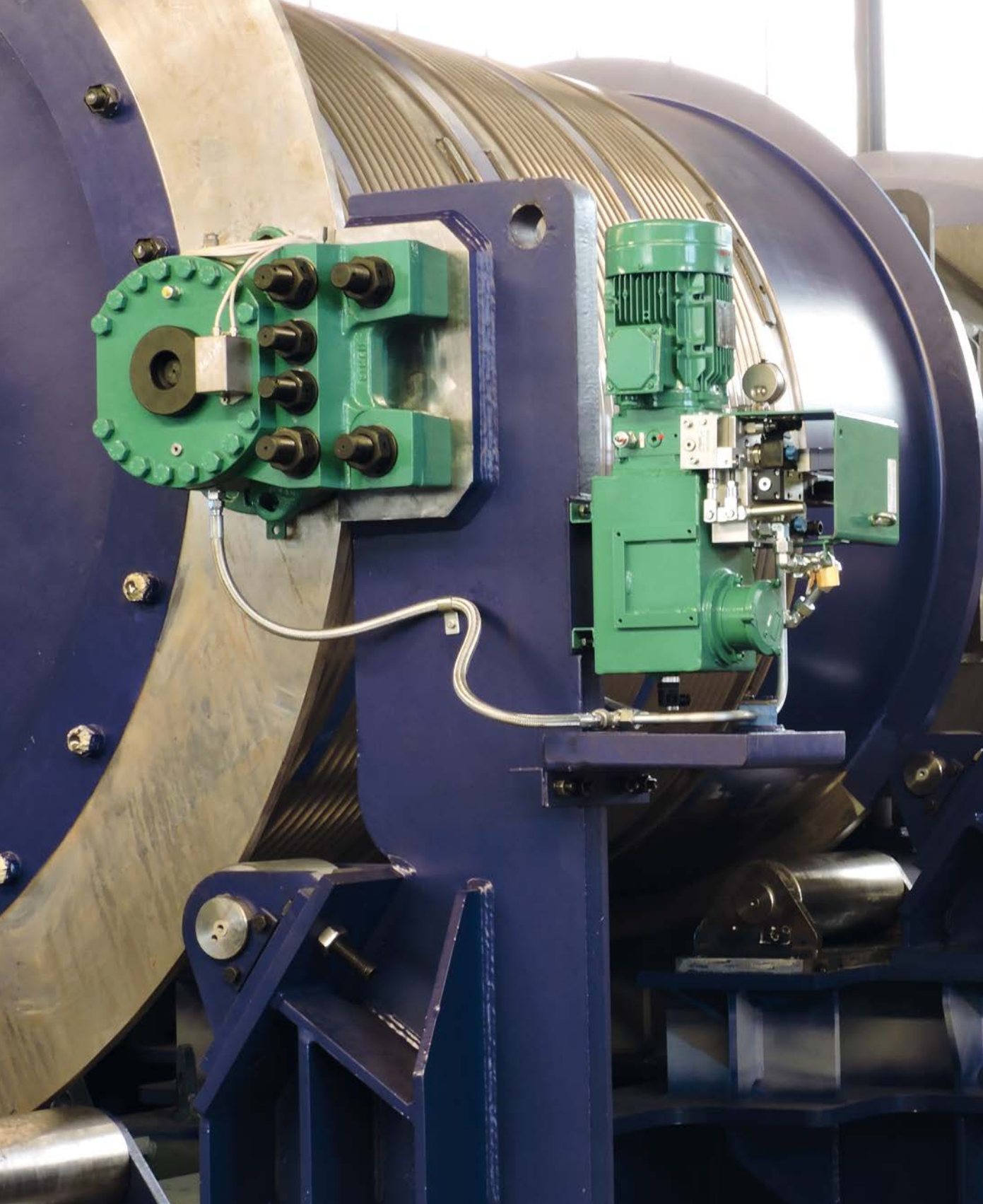

## CONTENT

---

<b>SERVICE BRAKES</b>	<b>12</b>
ELECTROMAGNETIC SERVICE BRAKES	15
DRUM BRAKES	27
HYDRAULIC SERVICE BRAKES	35
THRUSTOR SERVICE BRAKES	39
<b>EMERGENCY BRAKES</b>	<b>46</b>
ELECTROMAGNETIC EMERGENCY BRAKES	49
HYDRAULIC EMERGENCY BRAKES TYPE SH	55
HYDRAULIC EMERGENCY BRAKES TYPES SHD / TH	83
<b>ELECTRICAL POWER UNITS</b>	<b>98</b>
<b>HYDRAULIC POWER PACKS</b>	<b>114</b>
<b>CONTROL AND SAFETY SYSTEMS</b>	<b>128</b>
<b>DISCS &amp; DRUMS</b>	<b>144</b>
<b>DISC COUPLINGS</b>	<b>158</b>
<b>ELASTIC COUPLINGS</b>	<b>174</b>
<b>CARDAN SHAFTS</b>	<b>176</b>
<b>HYDRAULIC BUFFERS</b>	<b>182</b>
<b>BARREL-ROLLER COUPLINGS</b>	<b>188</b>

# SIME Brakes Industrial Braking Systems

## Service Brakes

### SERVICE BRAKES

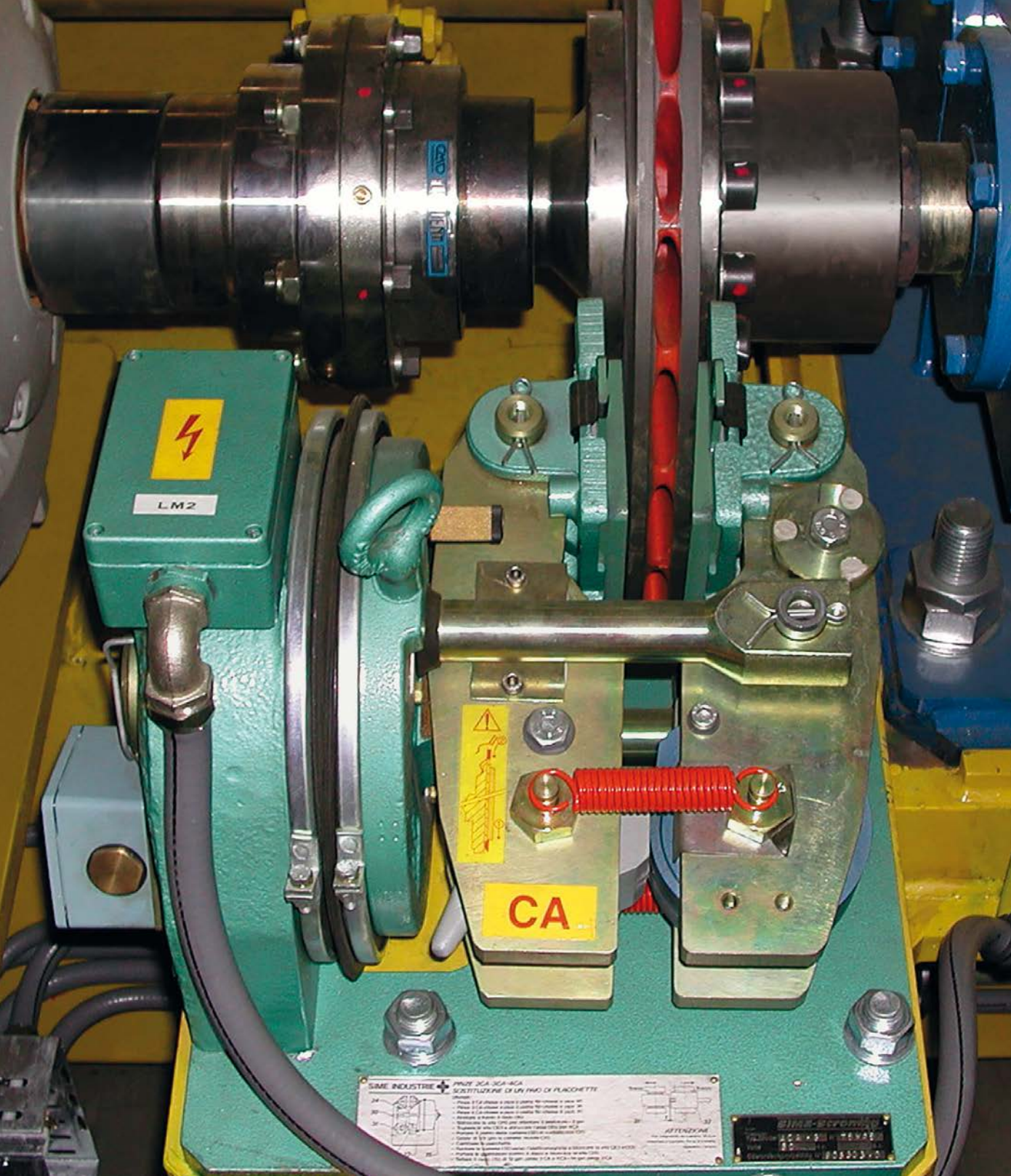

# SIME Brakes Industrial Braking Systems

## Service Brakes

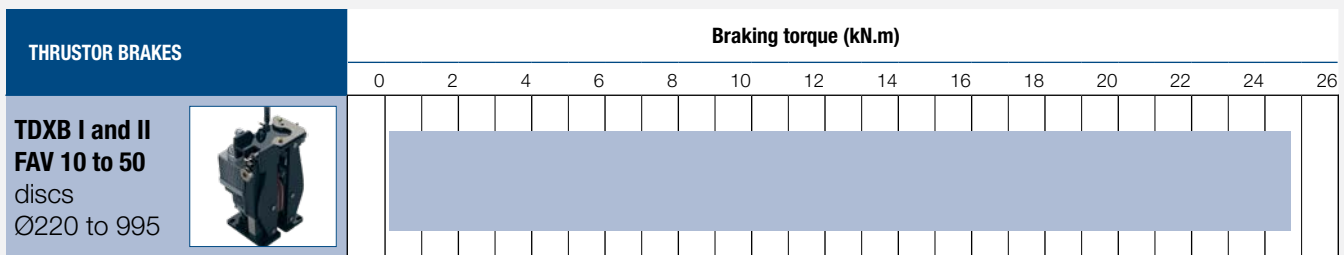
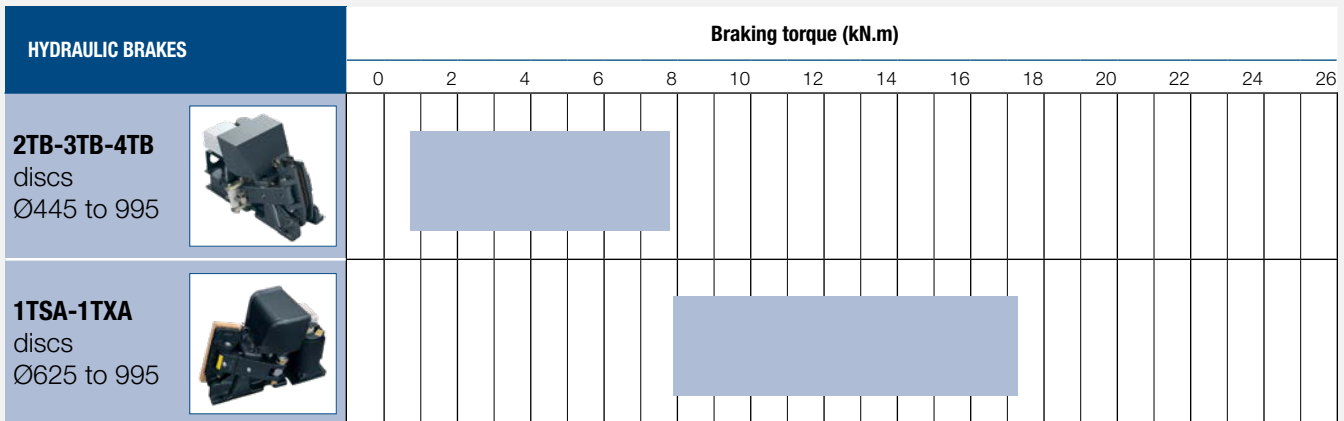
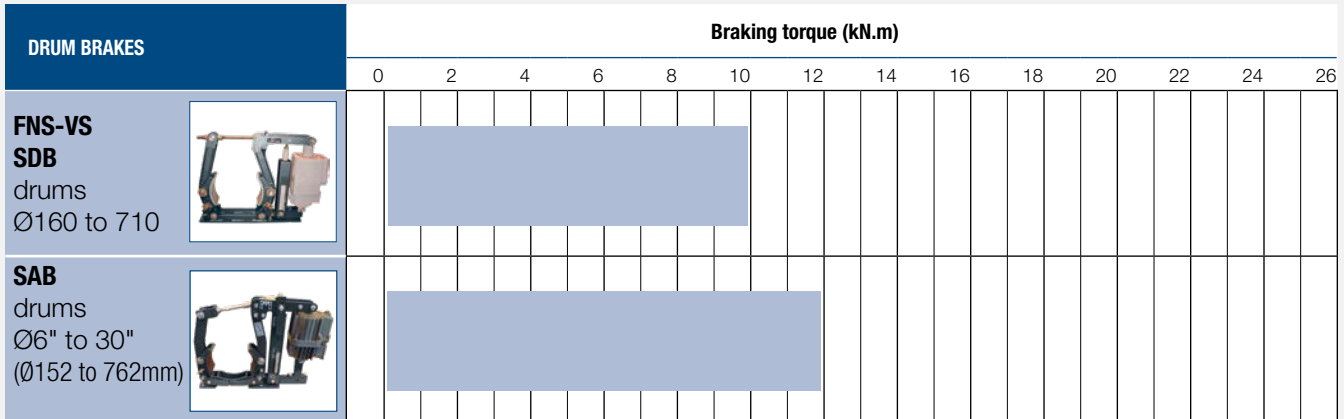
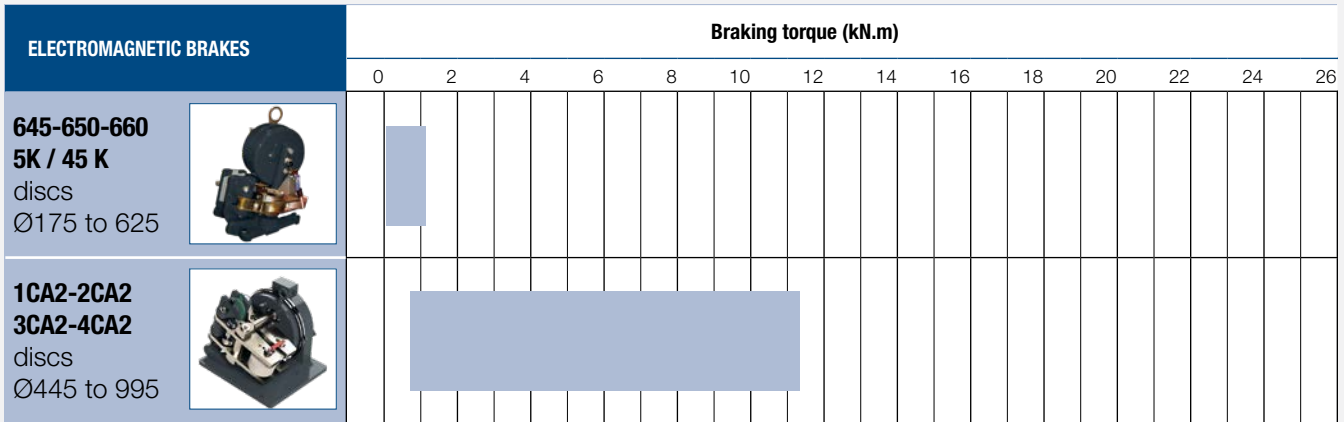

# SIME Brakes Industrial Braking Systems

## Service Brakes

### APPLICATIONS

- STEEL CRANES
- PORT CRANES
- NUCLEAR CRANES
- MASS TRANSPORTS

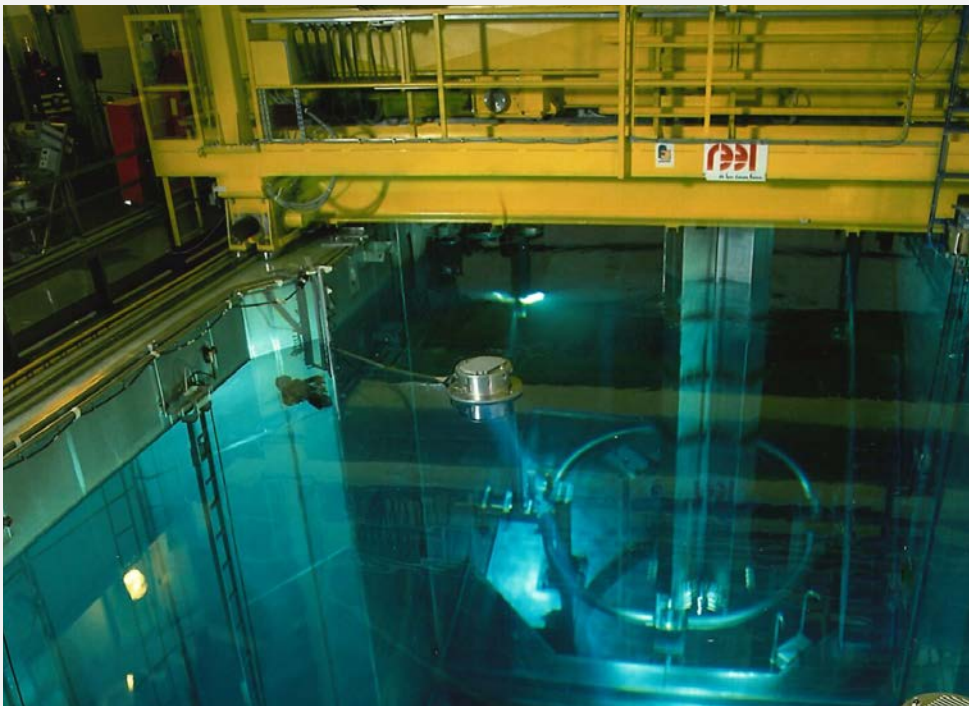

Photo courtesy of EDF

Four circular icons arranged horizontally, each containing a technical drawing of a brake component and a yellow banner with a key feature:

- ECONOMIC**
- COMPACT**
- RELIABLE**
- EASY MAINTENANCE**

# ELECTROMAGNETIC SERVICE BRAKES

MAIN CHARACTERISTICS	OPTIONS
<ul style="list-style-type: none"> <li>• FAILSAFE BRAKE BY SPRING APPLICATION</li> <li>• ELECTROMAGNETIC RELEASE</li> <li>• OPENING PROVING SWITCH</li> </ul>	<ul style="list-style-type: none"> <li>• MECHANICAL RELEASE LEVER</li> <li>• HYDRAULIC RELEASE</li> <li>• CLOSING PROVING SWITCH</li> <li>• MANUAL RELEASE CONTROL SWITCH</li> <li>• HIGH TEMPERATURE, IRON AND STEEL CONDITIONS</li> </ul>



**645-650-660**

- Association with discs Ø175 to 625
- Manual wear compensation
- Option:  
Mounting on a vertical axis disc



**5K - 5D  
45K - 45D**

- Association with discs Ø315 to 625
- Automatic wear compensation
- Option:  
Mounting on a vertical axis disc



**4CA2 - 3CA2  
2CA2 - 1CA2**

- Association with discs Ø445 to 995
- Automatic wear compensation
- Left and right hand calipers
- Option: Manual wear compensation

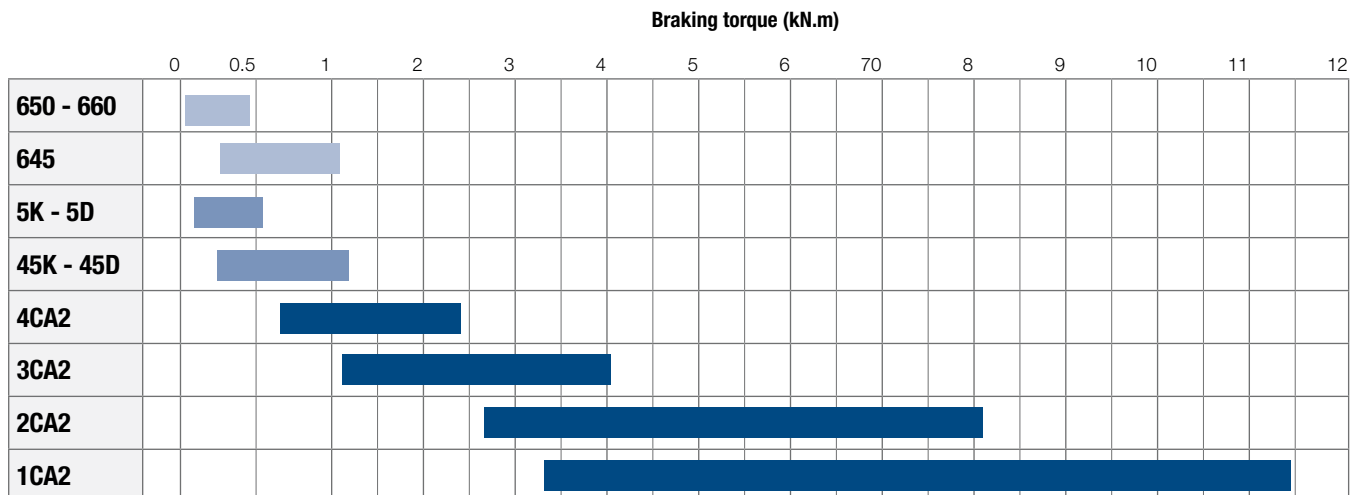

# SIME Brakes Industrial Braking Systems

## Service Brakes

# DISC BRAKE - 650 AND 660 CALIPERS

Revision number: T03150-01-G

Revision date: 10.04.2018

Fail safe braking  
 Spring application  
 Electromagnetic release  
 Manual lining wear compensation  
 Brake pads with wear indicator  
 Opening proving switch for PLC  
 With coil supply wire: 2 x 2mm<sup>2</sup>, length 2m

**Conditions of use:**

- Ambient temperature -10°C to +60°C
- Relative humidity ≤ 70%
- Dust in atmosphere ≥ 65µ

Other conditions, consult SIME-Stromag.

**Use:**

- Service brake for application ≤ 150 stops/h

**Options:**

- Lowering system with lever
- Hydraulic lowering system
- Mounting on vertical axis disc
- Marine protection
- Closing proving switch
- Manual release switch

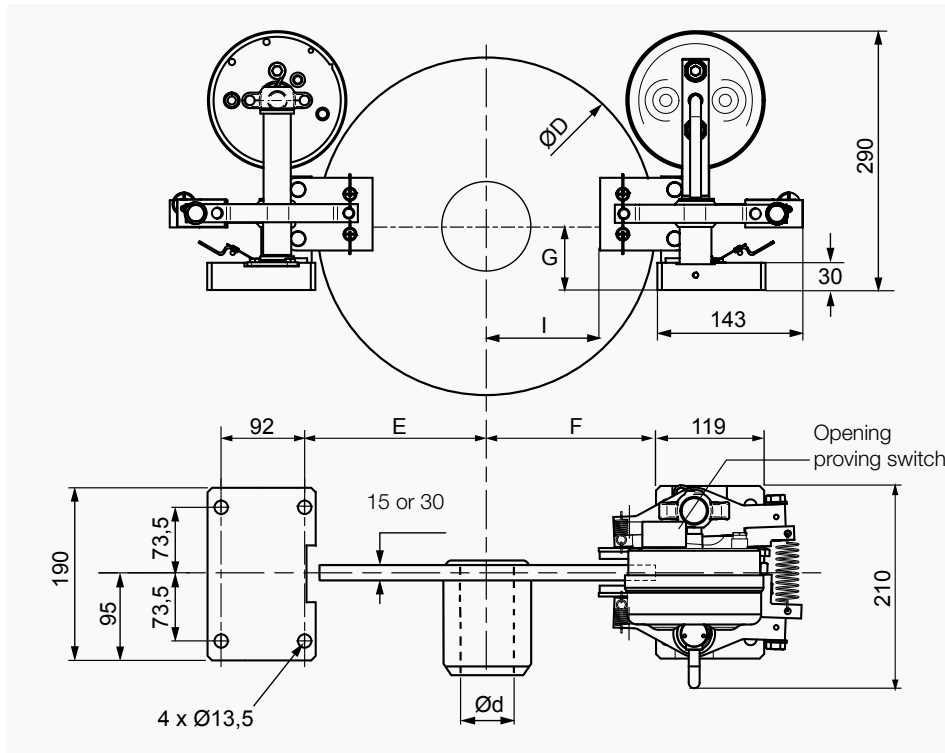

**Opening proving switch :**  
 250VAC maxi., 5A maxi., with interrupting capacity: 50VA maxi.  
 220VDC maxi., 5A maxi., with interrupting capacity: 50W maxi.

Compatible with PLC (Programmable Logic Controllers). An opening switch used with other equipment than PLC must not be reused with a PLC.

The opening switch is delivered with 3 x 0.75mm<sup>2</sup> cable, length 2m

Weight: 19 kg  
 Dimensions in mm

Response time at nominal torque : see the leaflet of the associated electrical power supply.

Discs			Thickness 15 mm								Thickness 30 mm							
Maximum speed of the disc for nominal torque		tr/mn	5000	4300	3600	3000	2400	2100	1900	1800	1500	3000	2700	2400	2100	1900	1800	1500
D	mm		175	220	260	315	395	445	495	550	625	315	355	395	445	495	550	625
d	mm		0-40	0-55	0-75	0-75	0-75	0-75	0-100	0-100	0-100	0-50	0-60	0-70	0-70	0-100	0-100	0-100
E	mm		118	128	143	173	213	238	263	293	328	173	193	213	238	263	293	328
F	mm		106	116	131	161	201	226	251	281	316	161	181	201	226	251	281	316
G	mm		85	85	85	75	60	50	45	45	25	75	60	60	50	45	45	25
I (approx. dimension)	mm		43	53	68	98	138	163	188	218	253	98	118	138	163	188	218	253
<b>Caliper 650 :</b>																		
Nominal torque for 1 caliper adjustable from 100% to 50%		N.m	110	130	150	190	260	300	350	390	460	190	220	260	300	350	390	460
Max. reaction on shaft	1 caliper	N	1600								1600							
	2 calipers	N	0		260	570	580	560	510	680	260	550	570	580	560	510	680	
<b>Caliper 660 :</b>																		
Nominal torque for 1 caliper adjustable from 100% to 60%		N.m	55	65	75	95	130	150	175	195	230	95	110	130	150	175	195	230
Max. reaction on shaft	1 caliper	N	800								800							
	2 calipers	N	0		130	285	290	280	255	340	130	275	285	290	280	255	340	



### DISC BRAKE - 645 CALIPER

Revision number: T03250-01-E

Revision date: 10.04.2018

Fail safe braking  
 Spring application  
 Electromagnetic release  
 Manual wear compensation  
 Brake pads with wear indicator  
 Opening proving switch for PLC  
 With coil supply wire: 2 x 2mm<sup>2</sup>, length 2m

**Conditions of use:**

- Ambient temperature -10°C to +60°C
- Relative humidity ≤ 70%
- Dust in atmosphere ≥ 65µ
- Other conditions, consult us.

**Use:**

- Service brake for application ≤ 150 stops/h

**Options:**

- Lowering system with lever
- Hydraulic lowering system
- Mounting on vertical axis disc
- Marine protection
- Closing proving switch
- Manual release switch

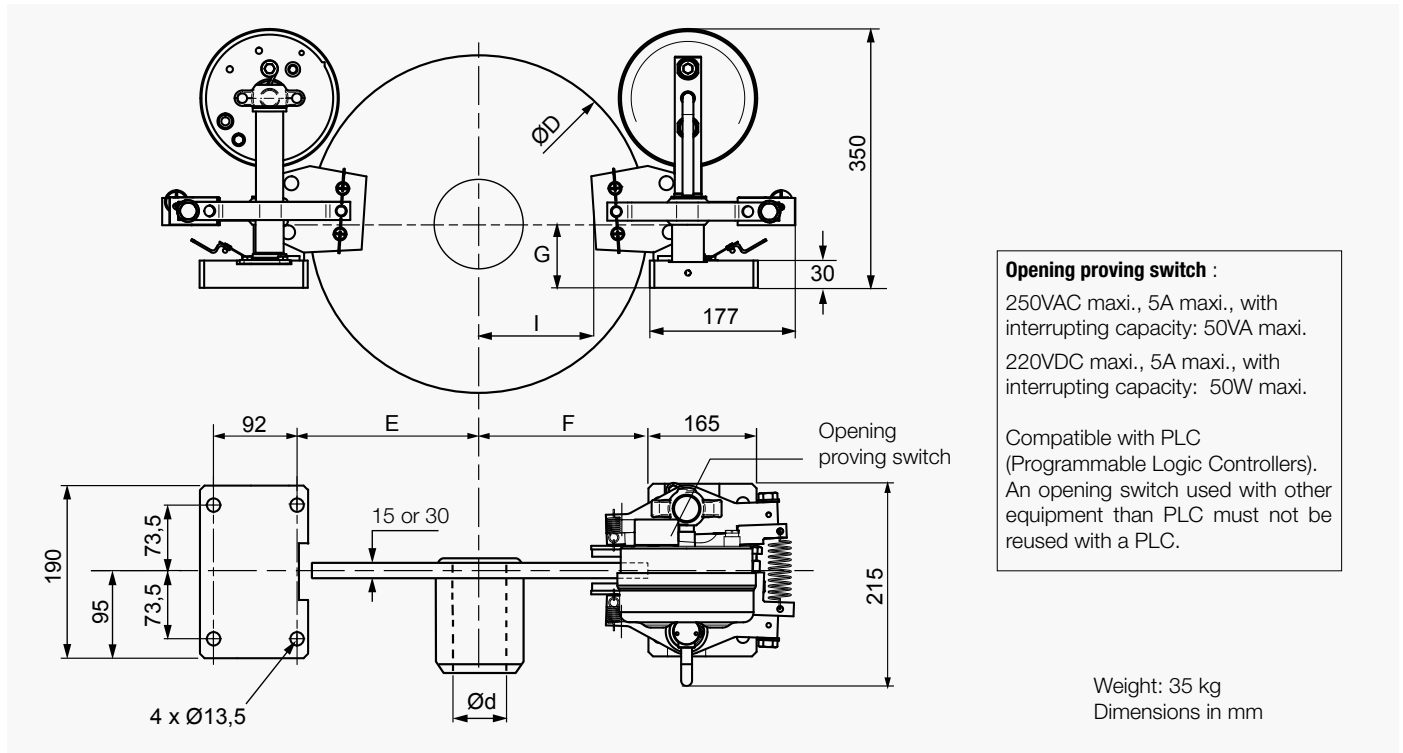

Response time at nominal torque : see the leaflet of the associated electrical power supply.

Designation	Discs		solid and thickness 15 mm						self-ventilated and thickness 30 mm						
			380	520	600	700	780	920	380	440	520	600	700	780	920
Nominal torque for 1 caliper adjustable from -30% to +20%	N.m		380	520	600	700	780	920	380	440	520	600	700	780	920
Maximum speed of the disc for nominal torque	rpm		3000	2400	2100	1900	1800	1500	3000	2700	2400	2100	1900	1800	1500
D	mm		315	395	445	495	550	625	315	355	395	445	495	550	625
d	mm		0-75	0-75	0-75	0-100	0-100	0-100	0-50	0-60	0-70	0-70	0-100	0-100	0-100
E	mm		173	213	238	263	293	328	173	193	213	238	263	293	328
F	mm		161	201	226	251	281	316	161	181	201	226	251	281	316
G	mm		95	80	70	65	65	45	95	80	80	70	65	65	45
l (approx. dimension)	mm		76	116	141	166	196	231	76	96	116	141	166	196	231
Max. reaction on shaft	1 caliper	N	3850						3850						
	2 calipers	N	405	405	810	895	780	1230	405	515	450	810	895	780	1230

# SIME Brakes Industrial Braking Systems

## Service Brakes

### DISC BRAKE - 5K AND 5KR CALIPERS

Revision number: T03350-01-E

Revision date: 09.04.2018

Fail safe braking / Spring application  
 Electromagnetic release  
 Automatic wear compensation  
 Detection of full lining wear  
 Brake pads with wear indicator  
 Opening proving switch  
 Association with discs th. 30mm (or 15mm in option)  
 With coil supply wire: 2 x 2mm<sup>2</sup>, length 2m

**Conditions of use:**

- Ambient temperature - 10°C to + 60°C
- Relative humidity ≤ 70 %
- Dust in atmosphere ≥ 65 μ

Other conditions, consult us.

**Options:**

- Lowering system with lever
- Hydraulic lowering system
- Marine protection
- Vertical mounting
- Reduced torque
- Closing proving switch
- Manual release switch
- Association with discs th. 15mm

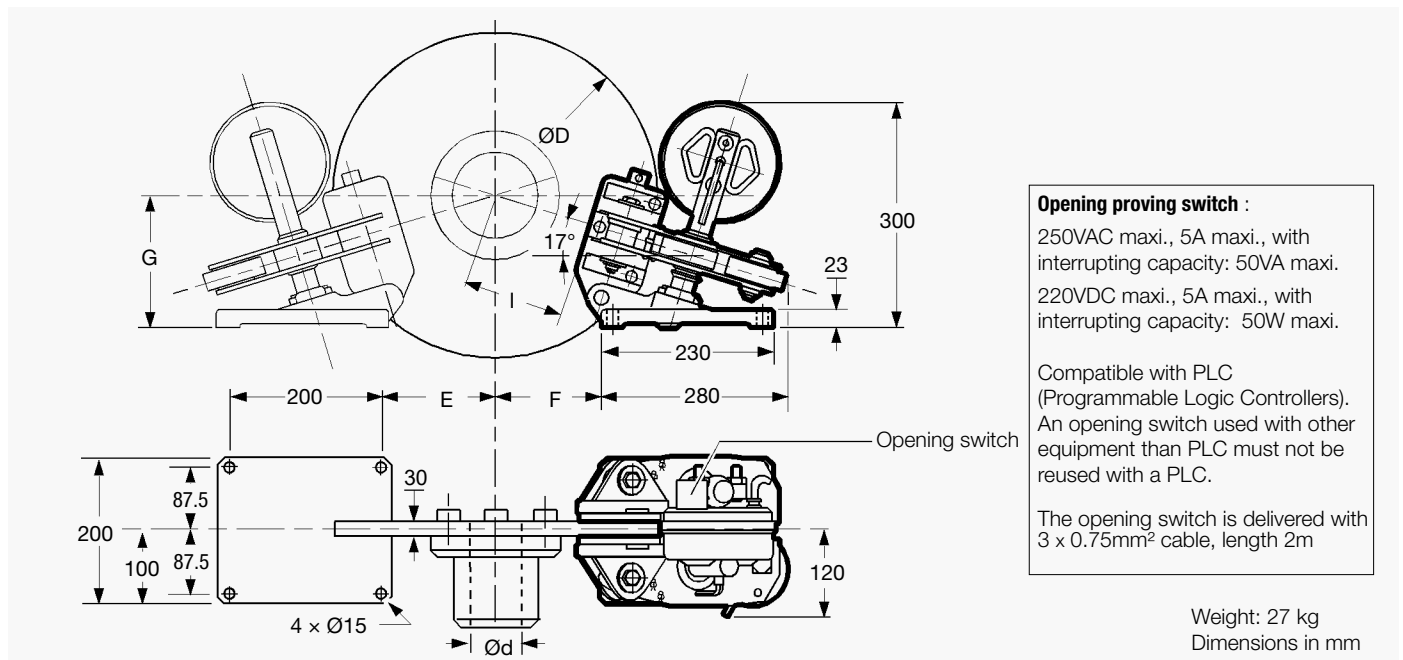

Response time at nominal torque : see the leaflet of the associated electrical power supply.

Discs		315	355	395	445	495	550	625
Maximum speed of the disc for nominal torque	rpm	3000	2700	2400	2100	1900	1800	1500
D	mm	315	355	395	445	495	550	625
d	mm	0-50	0-60	0-70	0-70	0-100	0-100	0-100
E	mm	100	120	140	160	190	220	255
F	mm	85	105	125	145	175	205	240
G	mm	160	164	170	180	185	195	205
l (approx. dimension)	mm	72	92	113	135	160	197	233
<b>Caliper 5K :</b>								
Nominal torque for 1 caliper adjustable from - 50% to +20%	N.m.	190	220	260	300	350	390	460
Maximum reaction on shaft	1 caliper N 2 calipers N				1950 1150			
<b>Caliper 5KR :</b>								
Nominal torque for 1 caliper adjustable from 100% to -50%	N.m.	95	110	130	150	175	195	230
Maximum reaction on shaft	1 caliper N 2 calipers N				815 480			

### DISC BRAKE - 5KE CALIPER

Revision number: T03400-01-D

Revision date: 21.03.2016

Fail safe braking  
 Spring application  
 Electromagnetic release  
 Electrical progressive braking  
 Automatic wear compensation  
 Detection of full lining wear  
 Opening proving switch  
 With coil supply wire: 2 x 2mm<sup>2</sup>, length 2m

**Conditions of use:**

- Ambient temperature - 10°C to + 60°C
- Relative humidity ≤ 70 %
- Dust in atmosphere ≥ 65 μ

Other conditions, consult us.

**Options:**

- Hydraulic release
- Marine protection
- Vertical mounting

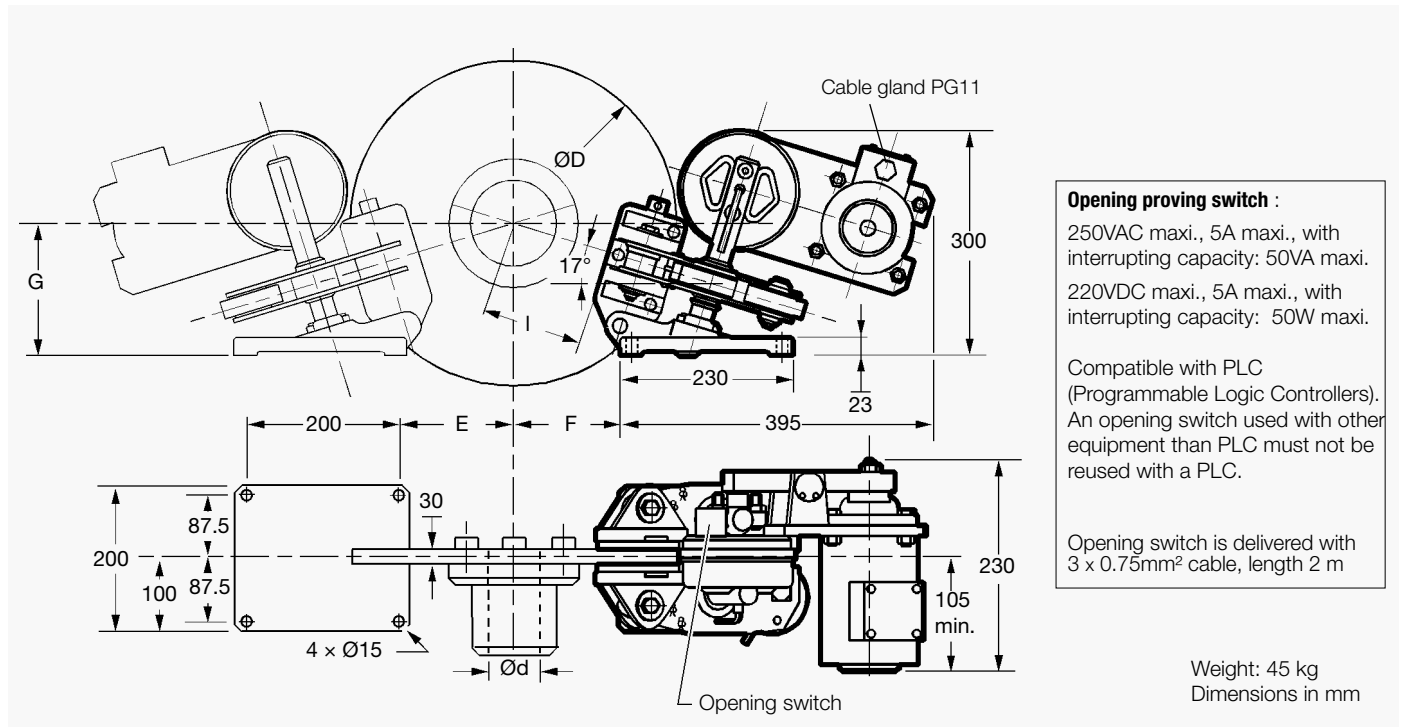

Response time at nominal torque : see the leaflet of the associated electrical power supply.

Discs		315	355	395	445	495	550	625
Progressive torque for 1 caliper adjustable from 0% to 100% *	N.m	190	220	260	300	350	390	460
Nominal torque for 1 caliper adjustable from 100% to -50%	N.m	190	220	260	300	350	390	460
Maximum speed of the disc for nominal torque	rpm	3000	2700	2400	2100	1900	1800	1500
D	mm	315	355	395	445	495	550	625
d	mm	0-50	0-60	0-70	0-70	0-100	0-100	0-100
E	mm	100	120	140	160	190	220	255
F	mm	85	105	125	145	175	205	240
G	mm	160	164	170	180	185	195	205
I (approx. dimension)	mm	72	92	113	135	160	197	233
Maximum reaction on shaft	1 caliper 2 calipers	N N	1950 1150					

\* For electro with working rate of 40%

# SIME Brakes Industrial Braking Systems

## Service Brakes

### DISC BRAKE - 5D AND 5DR CALIPERS

Revision number: T03360-01-E

Revision date: 21.03.2016

Fail safe braking  
 Spring application  
 Electromagnetic release  
 Automatic wear compensation  
 Brake pads with wear indicator  
 Opening proving switch  
 With coil supply wire: 2 x 2mm<sup>2</sup>, length 2m

**Conditions of use:**

- Ambient temperature - 10°C to + 60°C
- Relative humidity ≤ 70 %
- Dust in atmosphere ≥ 65 μ

Other conditions, consult us.

**Options:**

- Manual release lever
- Hydraulic release
- Marine protection
- Vertical mounting
- Reduced torque
- Closing proving switch
- Manual release switch

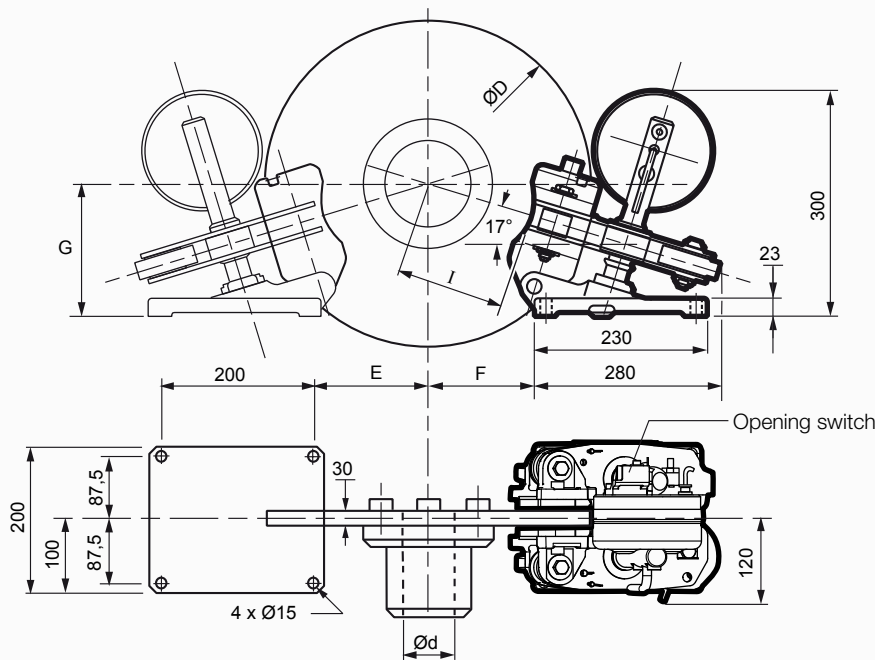

**Opening proving switch :**  
 250VAC maxi., 5A maxi., with interrupting capacity: 50VA maxi.  
 220VDC maxi., 5A maxi., with interrupting capacity: 50W maxi.

Compatible with PLC  
 (Programmable Logic Controllers).  
 An opening switch used with other equipment than PLC must not be reused with a PLC.

The opening switch is delivered with 3 x 0.75mm<sup>2</sup> cable, length 2m

Weight: 27 kg  
 Dimensions in mm

Response time at nominal torque : see the leaflet of the associated electrical power supply.

Discs		220 M30	260 M30	315 M30	315	355	395	445	495	550	625
Maximum speed of the disc for nominal torque	rpm	4300	3600	3000	3000	2700	2400	2100	1900	1800	1500
D	mm	220	260	315	315	355	395	445	495	550	625
d	mm	20-55	30-55	35-60	0-50	0-60	0-70	0-70	0-100	0-100	0-100
E	mm	65	80	100	100	120	140	160	190	220	255
F	mm	50	65	85	85	105	125	145	175	205	240
G	mm	150	153	160	160	164	170	180	185	195	205
l (approx. dimension)	mm	51	68	88	88	108	128	151	176	213	248
<b>Caliper 5D :</b>											
Nominal torque for 1 caliper adjustable from - 50% to +20%	N.m.	130	150	190	190	220	260	300	350	390	460
Maximum reaction on shaft	1 caliper N 2 calipers N	1950 1150									
<b>Caliper 5DR :</b>											
Nominal torque for 1 caliper adjustable from 100% to -50%	N.m.	65	75	95	95	110	130	150	175	195	230
Maximum reaction on shaft	1 caliper N 2 calipers N	815 480									

### DISC BRAKE - 5DE CALIPER

Revision number: T03410-01-D

Revision date: 22.03.2016

Fail safe braking  
 Spring application  
 Electromagnetic release  
 Electrical progressive braking  
 Automatic wear compensation  
 Detection of full lining wear  
 Opening proving switch  
 With coil supply wire: 2 x 2mm<sup>2</sup>, length 2m

**Conditions of use:**

- Ambient temperature - 10°C to + 60°C
- Relative humidity ≤ 70 %
- Dust in atmosphere ≥ 65 μ

Other conditions, consult us.

**Options:**

- Hydraulic release
- Marine protection
- Vertical mounting

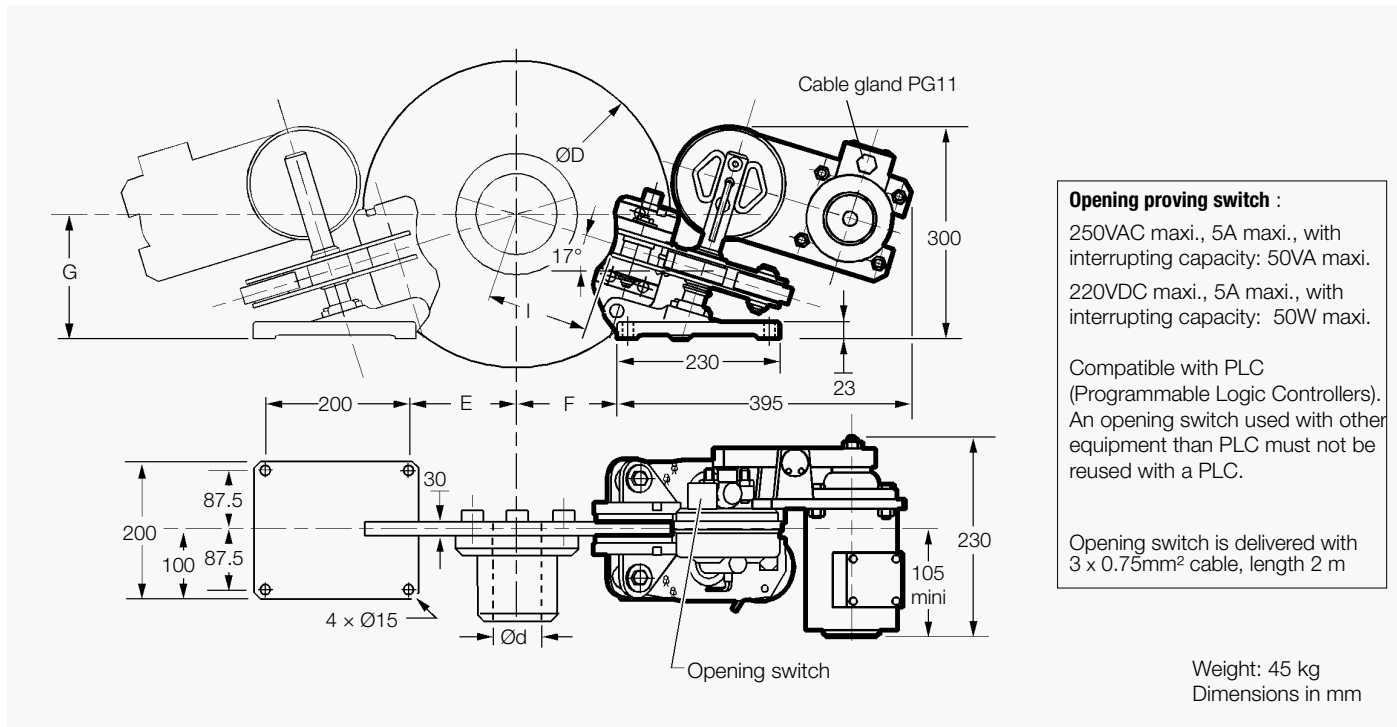

Response time at nominal torque : see the leaflet of the associated electrical power supply.

Discs			220M30	260M30	315M30	315	355	395	445	495	550	625	
Progressive torque for 1 caliper adjustable from 0% to 100% *	N.m		130	150	190	190	220	260	300	350	390	460	
Nominal torque for 1 caliper adjustable from 100% to -50%	N.m		130	150	190	190	220	260	300	350	390	460	
Maximum speed of the disc for nominal torque	rpm		4300	3600	3000	3000	2700	2400	2100	1900	1800	1500	
D	mm		220	260	315	315	355	395	445	495	550	625	
d	mm		20-55	30-55	35-60	0-50	0-60	0-70	0-70	0-100	0-100	0-100	
E	mm		65	80	100	100	120	140	160	190	220	255	
F	mm		50	65	85	85	105	125	145	175	205	240	
G	mm		150	153	160	160	164	170	180	185	195	205	
I (approx. dimension)	mm		51	68	88	88	108	128	151	176	213	248	
Maximum reaction on shaft	1 caliper	N							1950				
	2 calipers	N							1150				

\* For electro with working rate of 40%

# SIME Brakes Industrial Braking Systems

## Service Brakes

### DISC BRAKE - 45K and 45D calipers

Revision number: T00140-01-J

Revision date: 10.04.2018

Fail safe braking  
 Spring application  
 Electromagnetic release  
 Automatic linings wear compensation  
 Opening proving switch  
 Coil with supply wire:  $2 \times 2\text{mm}^2$ , length 2m  
 Association with 30mm thick discs (or 15mm in option)  
 Shoes DIN (caliper 45D) for discs thickness 30mm only.

**Conditions of use :**

- Ambient temperature  $-20^\circ\text{C}$  to  $+60^\circ\text{C}$
- Relative humidity  $\leq 70\%$
- Dust in atmosphere  $\geq 65\ \mu$
- Other conditions, consult us.

**Use:**

- Service brake for application  $\leq 600$  cycles / h  
 Possibility of quick manoeuvres :  
 1000 cycles/h during 15s every 2 mn

**Options:**

- Lowering system with lever
- Hydraulic lowering system
- Manual wear compensation (RM)
- Marine protection
- SIDHT steel industry high temperature
- Bearing brackets for mounting in place of a caliper 645.
- Mounting on a vertical axis disc.
- Closing proving switch
- Manual release switch

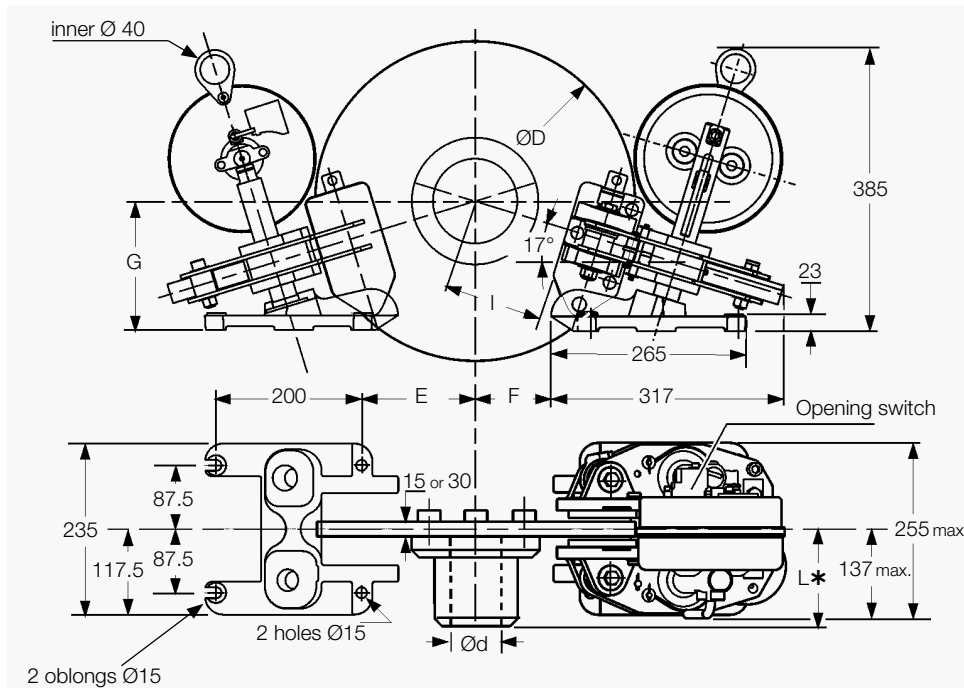

**Nota :**  
 The 45K-RM and 45D-RM calipers (manual wear compensation option) have the same overall dimensions as the 45K and 45D calipers with automatic wear compensation.

**\* ATTENTION**  
 For discs Ø315 to 395, the length of 137 max. is higher than the length L of the standard hub. Provide space at the rear of the hub by means of a spacer.

**Opening proving switch :**  
 250VAC maxi., 5A maxi., with interrupting capacity: 50VA maxi.  
 220VDC maxi., 5A maxi., with interrupting capacity: 50W maxi.  
 Compatible with PLC (Programmable Logic Controllers). An opening switch used with other equipment than PLC must not be reused with a PLC.

Weight: 41 kg  
 Dimensions in mm

Response time at nominal torque : see the leaflet of the associated electrical power supply.  
 Caliper delivered in standard with WS1-5 lining.  
 For energy applications. use WS1-3 (torque loss of 20%).

Designation	Discs	solid and thickness 15 mm (option)							ventilated and thickness 30 mm						
		315	355	395	445	495	550	625	315	355	395	445	495	550	625
D Disc diameter	mm	315	355	395	445	495	550	625	315	355	395	445	495	550	625
Nominal torque for 1 caliper adjustable from -30% to +20%	N.m	410	470	560	650	750	840	990	410	470	560	650	750	840	990
Maximum speed of the disc for nominal torque	r.p.m.	3000	2700	2400	2100	1900	1800	1500	3000	2700	2400	2100	1900	1800	1500
d	mm	0-75	0-75	0-75	0-75	0-100	0-100	0-100	0-50	0-60	0-70	0-70	0-100	0-100	0-100
E	mm	100	120	140	160	190	220	255	100	120	140	160	190	220	255
F	mm	50	70	90	110	140	170	205	50	70	90	110	140	170	205
G	mm	160	164	170	180	185	195	205	160	164	170	180	185	195	205
I (calipers 45K, 45K-RM)	mm	75	95	116	138	168	200	236	75	95	116	138	168	200	236
I (caliper 45D)	mm								75	95	116	138	168	200	236
I (caliper 45D-RM)	mm								96	116	137	159	189	221	257
Maximum reaction on shaft	1 Caliper	N							4200						
	2 Calipers	N							2450						



# SIME Brakes Industrial Braking Systems

## Service Brakes

### DISC BRAKE - 3CA2 CALIPER

Revision number: T10050-01-D

Revision date: 09.04.2019

Fail safe braking  
Braking by spring application  
Electromagnetic release  
Automatic wear compensation  
Opening proving switch  
Brake pads with wear indicator

**Working conditions:**

- Ambient temperature: -10°C to +60°C
- Relative humidity ≤ 70%
- Dust in atmosphere ≥ 65µ

Other conditions, consult us.

**Use:**  
Any application up to 1000act/h

**Options:**

- Manual release lever
- Hydraulic release
- Manual wear compensation
- Load regulated lowering
- Steelworks flameproof protection
- Marine protection / • Special paint
- Closing proving switch
- Switch on release nut

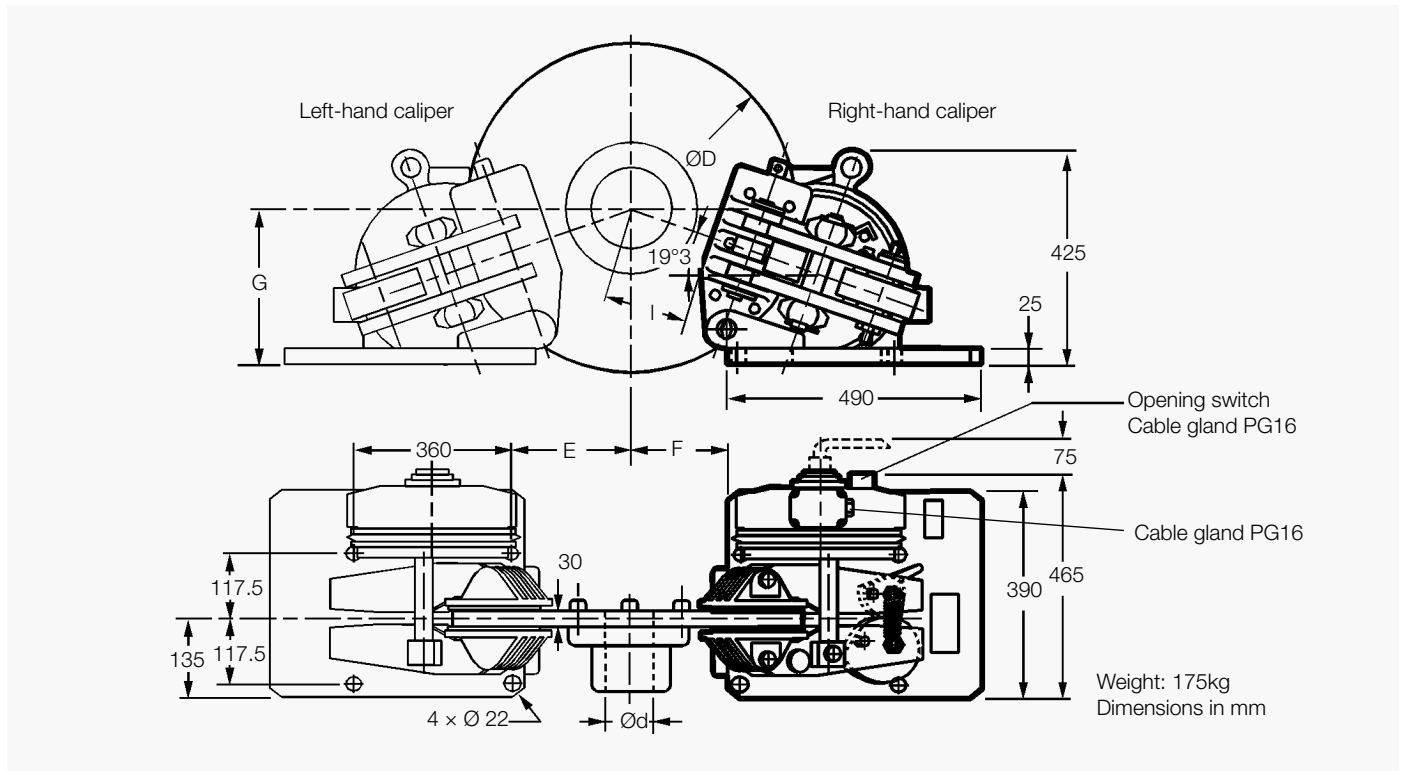

Response time at nominal torque : see the leaflet of the associated electrical power supply.

Discs		445	495	550	625	705	795
Nominal torque for 1 caliper adjustable from -30 to +20%	N.m	1600	1850	2100	2500	2900	3350
Maximum disc speed for nominal torque	r.p.m.	2100	1900	1800	1500	1300	1200
D	mm	445	495	550	625	705	795
d	mm	0-70	0-100	0-100	0-100	0-120	0-130
E	mm	100	120	150	185	225	265
F	mm	80	100	130	165	205	245
G	mm	285	295	305	315	330	345
l (approx. dimension)	mm	90	115	145	180	225	265
Maximum reaction on shaft	1 caliper	N					
	2 calipers	N					

**Opening proving switch :**  
250VAC maxi., 5A maxi., with interrupting capacity: 50VA maxi.  
220VDC maxi., 5A maxi., with interrupting capacity: 50W maxi.

Compatible with PLC (Programmable Logic Controllers).  
An opening switch used with other equipment than PLC must not be reused with a PLC.



### DISC BRAKE - 2CA2 AND 1CA2 CALIPERS

Revision number: T10051-01-D / T10065-02-B

Revision date: 09.04.2019

Fail safe braking  
Braking by spring application  
Electromagnetic release  
Automatic wear compensation  
Opening proving switch  
Brake pads with wear indicator

**Working conditions:**

- Ambient temperature: -10°C to +60°C
  - Relative humidity ≤ 70%
  - Dust in atmosphere ≥ 65µ
- Other conditions, consult us.

**Options:**

- Manual wear compensation
- Steelworks flameproof protection
- Marine protection
- Special paint

**Use:**

Any application up to 600act/h

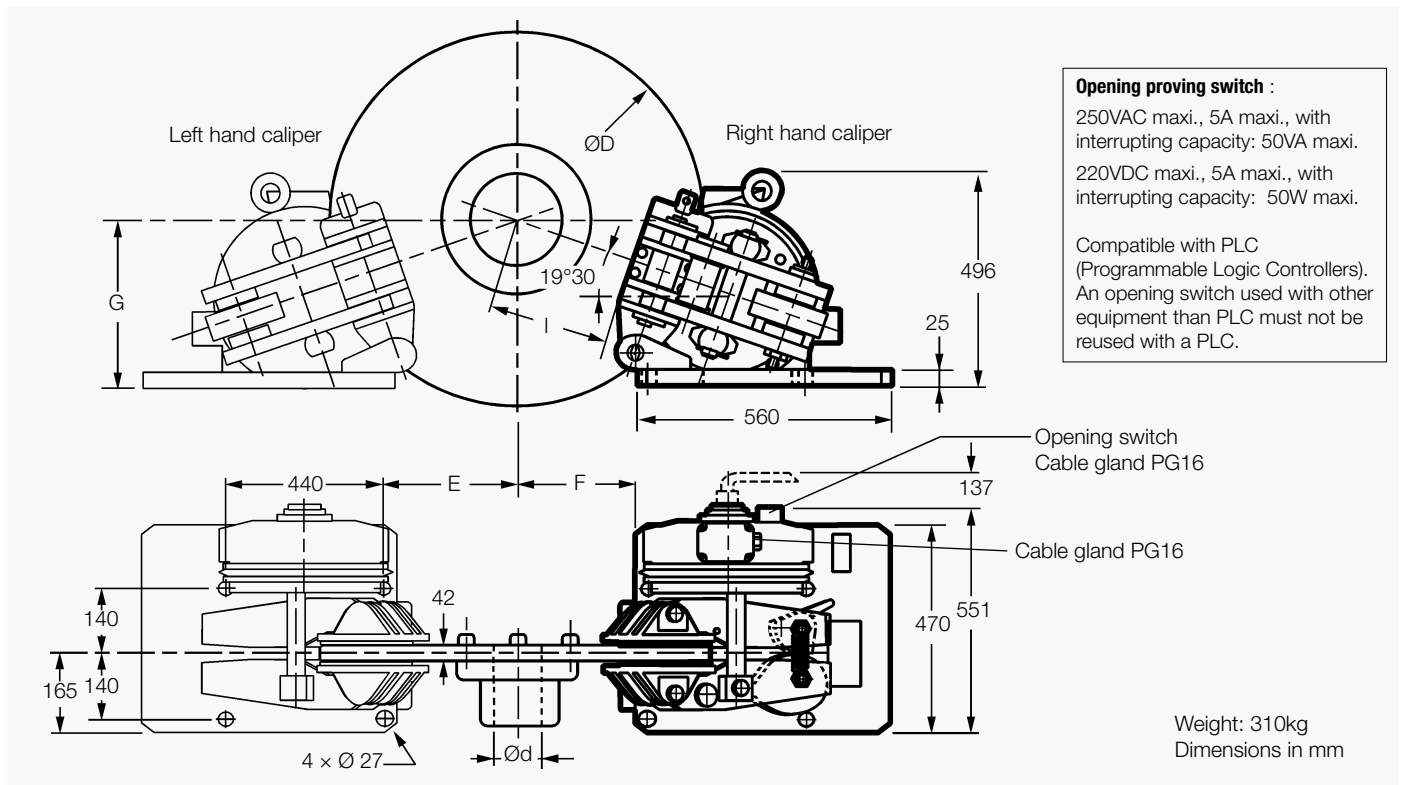

Discs		625	795	995
D	mm	625	795	995
d	mm	40-140	40-180	40-180
E	mm	157	250	345
F	mm	127	220	315
G	mm	353	385	415
I (approx. dimension)	mm	174	268	368

Response time at nominal torque : see the leaflet of the associated electrical power supply.

Discs		625	795	995
<b>2CA2</b>				
Nominal torque for 1 caliper adjustable from -30 to +20%	N.m	3 800	5 150	6 700
Maximum disc speed for nominal torque	r.p.m.	1 500	1 200	900
Maximum reaction on shaft	1 caliper	N		
	2 calipers	N		

Discs		625	795	995
<b>1CA2</b>				
Nominal torque for 1 caliper adjustable from -50 to 100%	N.m	6 610	8 800	11 370
Maximum disc speed for nominal torque	r.p.m.	310	250	200
Maximum reaction on shaft	1 caliper	N		
	2 calipers	N		

# SIME Brakes Industrial Braking Systems

## Service Brakes

### APPLICATIONS

- MINING
- HYDRO POWER
- OIL & GAS
- HARBOUR & SHIPPING
- STEEL
- POWER
- CEMENT



# DRUM BRAKES

MAIN CHARACTERISTICS	OPTIONS
<ul style="list-style-type: none"> <li>• FAILSAFE BRAKES</li> <li>• SPRING APPLIED ELECTROHYDRAULIC THRUSTOR RELEASED</li> <li>• ADJUSTABLE BRAKING TORQUE</li> </ul>	<ul style="list-style-type: none"> <li>• OPENING PROVING SWITCH</li> <li>• FULL LINING WEAR INDICATORS</li> <li>• HAND RELEASE LEVER</li> <li>• HIGH TEMPERATURE, SPECIAL PROTECTION, DELAY. ...</li> </ul>



**SDB**

- Ass. with drums  $\varnothing$  160 to 710
- Standard DIN 15435
- Voltage: 230/400VAC 50Hz
- Automatic lining wear compensation
- Protection C4M



**SAB**

- Ass. drums  $\varnothing$  6" to 30" (152 to 762mm)
- Standard AISE N.11 - 63.120
- Voltage: 230/460VAC 60Hz
- Automatic lining wear compensation
- Protection C4M



**FNS-VS**

- Ass. with drums  $\varnothing$  160 to 710mm
- Standard DIN 15435
- Voltage: 230/400VAC 50Hz
- Protection C3M
- Option: certificat ATEX / thrustor

**Braking torque (kN.m)**

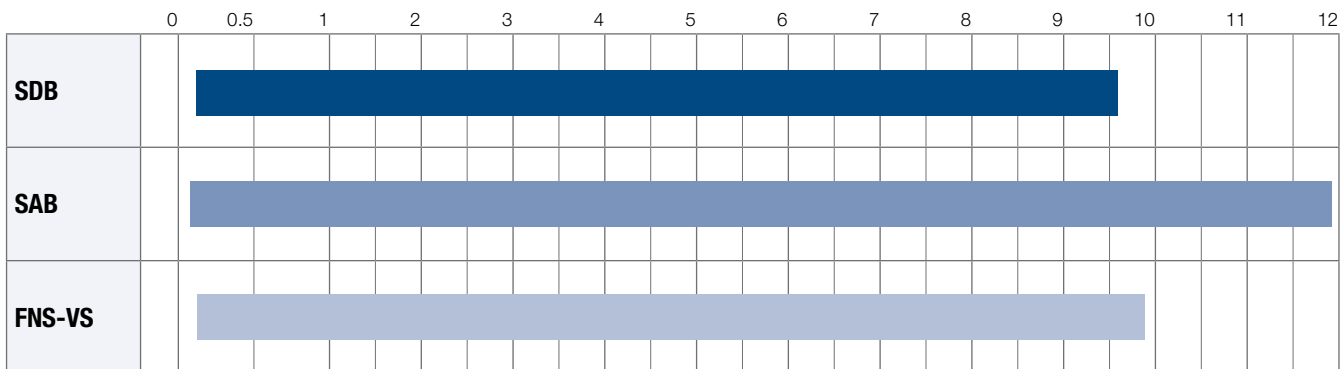

# SIME Brakes Industrial Braking Systems

## Service Brakes

### DRUM BRAKE - SDB BRAKES

Revision number: T10110-01-G

Revision date: 21.01.2020

**Standard DIN 15435**

- Spring application braking
- Thrustor release
- Standard voltage 230/400 VAC 50Hz
- Protection level C4M
- Automatic lining wear compensation

- Brake shoe auto-aligning device
- Scale for torque adjustment
- Brake lever synchronization
- Aluminium shoes with non abestos organic linings
- Self lubricated bushings at main hinge points
- Galvanized steel spindles and hinges

**Operating conditions**

- Ambient temperature : -20°C to 50°C
- Relative humidity no higher than 90%
- IP rating: IP65

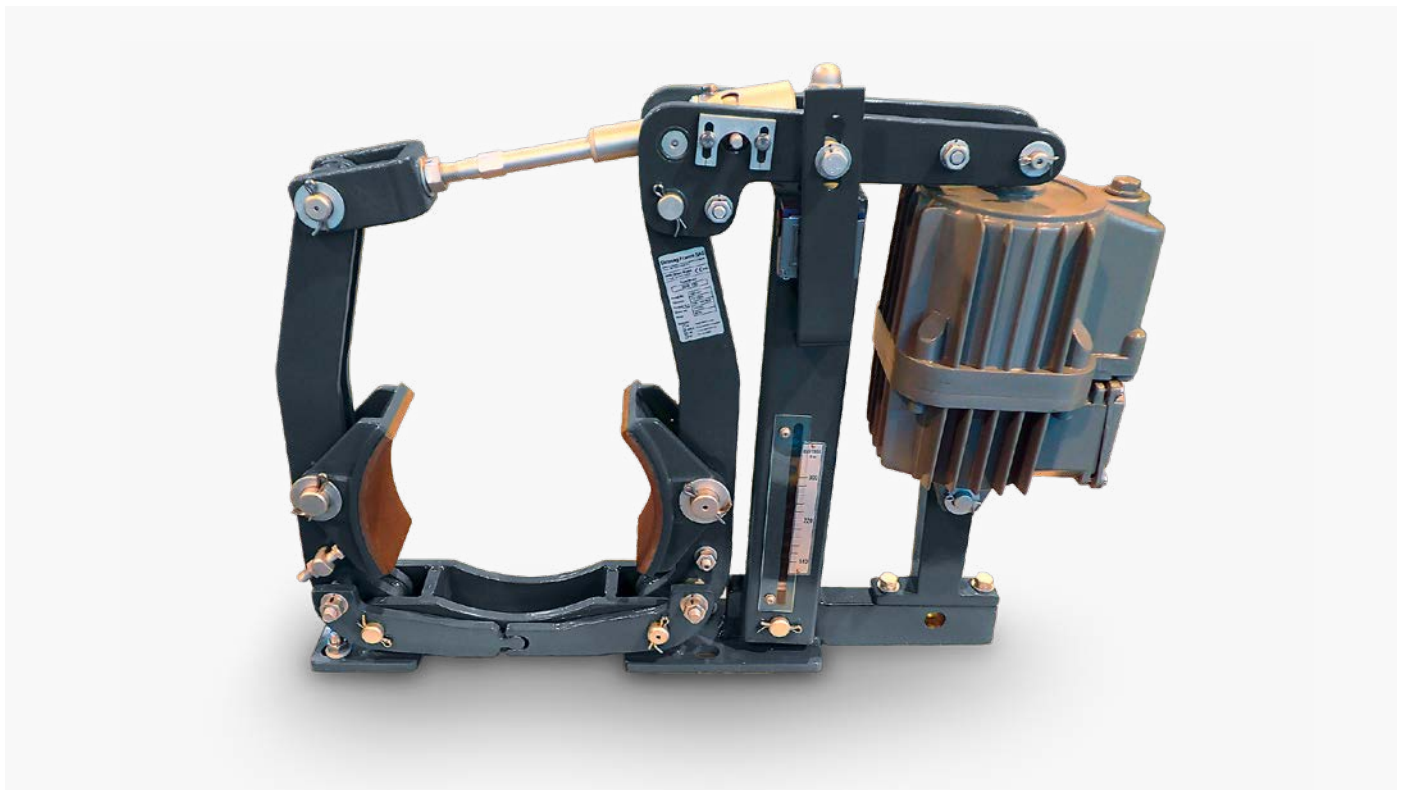

**Options :**

<b>HRL</b>	Manual release lever with or without stop
<b>BRLS</b>	Switch for opening monitoring
<b>LWI</b>	Full lining wear indicators
<b>SS1</b>	Special Switch: Schneider XCKM 110H29
<b>SS2</b>	Special Switch: Schmersal Z4VH335 11Z
<b>AV - DV</b>	Thrustor delay : Ascent Valve or Descent Valve
<b>SV 415V 50Hz</b> <b>SV 500V 50Hz</b> <b>SV 480V 60Hz</b>	Special Voltage
<b>SW</b>	Steel Works (specific oil in the thrustor + heat resistant sealings)
<b>SPA</b>	Special paint according to the customer

**Thrustor Technical Data :**

Thrustor type	Power (W)	Current at 400 V (A)	Weight (kg)
<b>TS 230/5</b>	165	0.52	10
<b>TS 300/5</b>	200	0.46	14
<b>TS 500/6</b>	200	0.48	21
<b>TS 800/6</b>	330	1.42	24
<b>TS 1210/6</b>	330	1.44	39
<b>TS 2010/6</b>	450	1.45	39
<b>TS 3010/6</b>	550	1.46	40

### DRUM BRAKE - SDB BRAKES

Revision number: T10110-01-G

Revision date: 21.01.2020

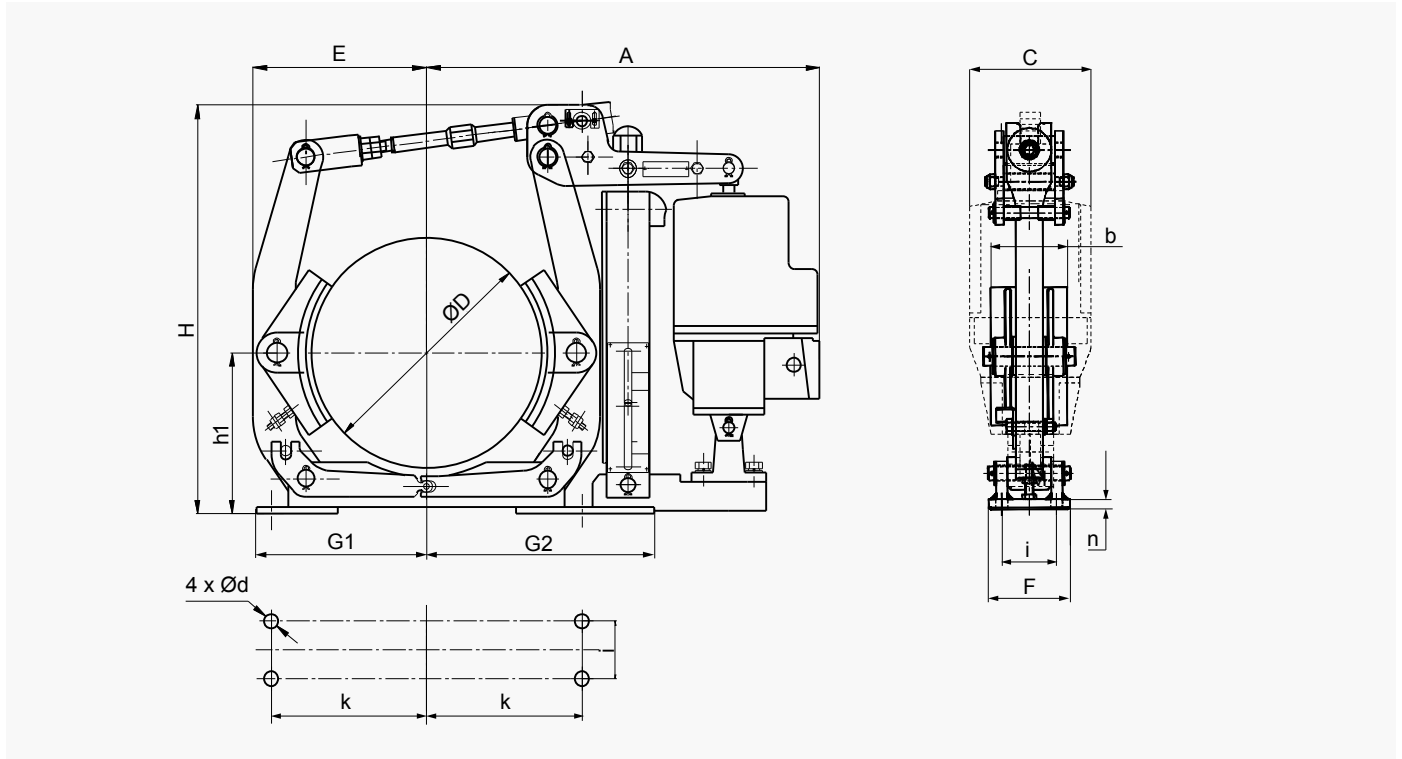

BRAKE TYPE	THRUSTOR	TORQUE (N.m.)		WEIGHT (kg)	DIMENSIONS (mm)													
		min.	max.		A	b	C	D	d	E	F	G1	G2	H	h1	i	k	n
SDB 160	TS 230/5	80	160	28	428	65	160	160	14	140	85	145	195	418	132	55	130	8
	TS 300/5	110	260	35	470	70	160	200	14	172	90	165	255	490	160	55	145	10
SDB 250	TS 230/5	140	300	45	533	90	160	250	18	202	110	200	290	583	190	65	180	12
	TS 300/5	180	380	48			195											
	TS 500/6	300	600	53	570													
SDB 315	TS 230/5	180	340	70	670	110	160	315	18	253	115	245	330	585	230	80	220	14
	TS 300/5	250	500	70			195											
	TS 500/6	315	770	75			195											
	TS 800/6	630	1200	80			195											
SDB 400	TS 500/6	400	960	138	695	140	195	400	22	310	160	310	420	715	280	100	270	14
	TS 800/6	630	1500	140			240							775				
	TS 1210/6	1000	2400	155			810											
SDB 500	TS 800/6	800	1920	176	925	180	240	500	22	380	180	365	535	803	340	130	325	21
	TS 1210/6	1250	3000	204										830				
	TS 2010/6	2000	4800	204														
SDB 630	TS 1210/6	1800	3780	310	1150	225	240	630	27	465	220	450	600	1025	420	170	400	20
	TS 2010/6	2500	6000	310														
	TS 3010/6	4000	8500	315														
SDB 710	TS 2010/6	3150	6000	435	1180	225	240	710	27	520	240	500	630	1135	470	190	450	25
	TS 3010/6	5000	9600	441														

# SIME Brakes Industrial Braking Systems

## Service Brakes

### DRUM BRAKE - SAB BRAKES

Revision number: T10110-02-F

Revision date: 13.02.2020

#### Standard AISE N. 11 - 63.120

- Spring application braking
- Thrustor release
- Standard voltage 230/460 VAC 60Hz
- Paint color RAL7021
- Protection level C4M

- Automatic lining wear compensation
- Brake shoe auto-aligning device
- Scale for torque adjustment
- Brake lever synchronization
- Aluminium shoes with non asbestos organic linings
- Self lubricated bushings at main hinge points
- Galvanized steel spindles and hinges

#### Operating conditions

- Ambient temperature : -20°C to 50°C
- Relative humidity no higher than 90%
- IP rating : IP65

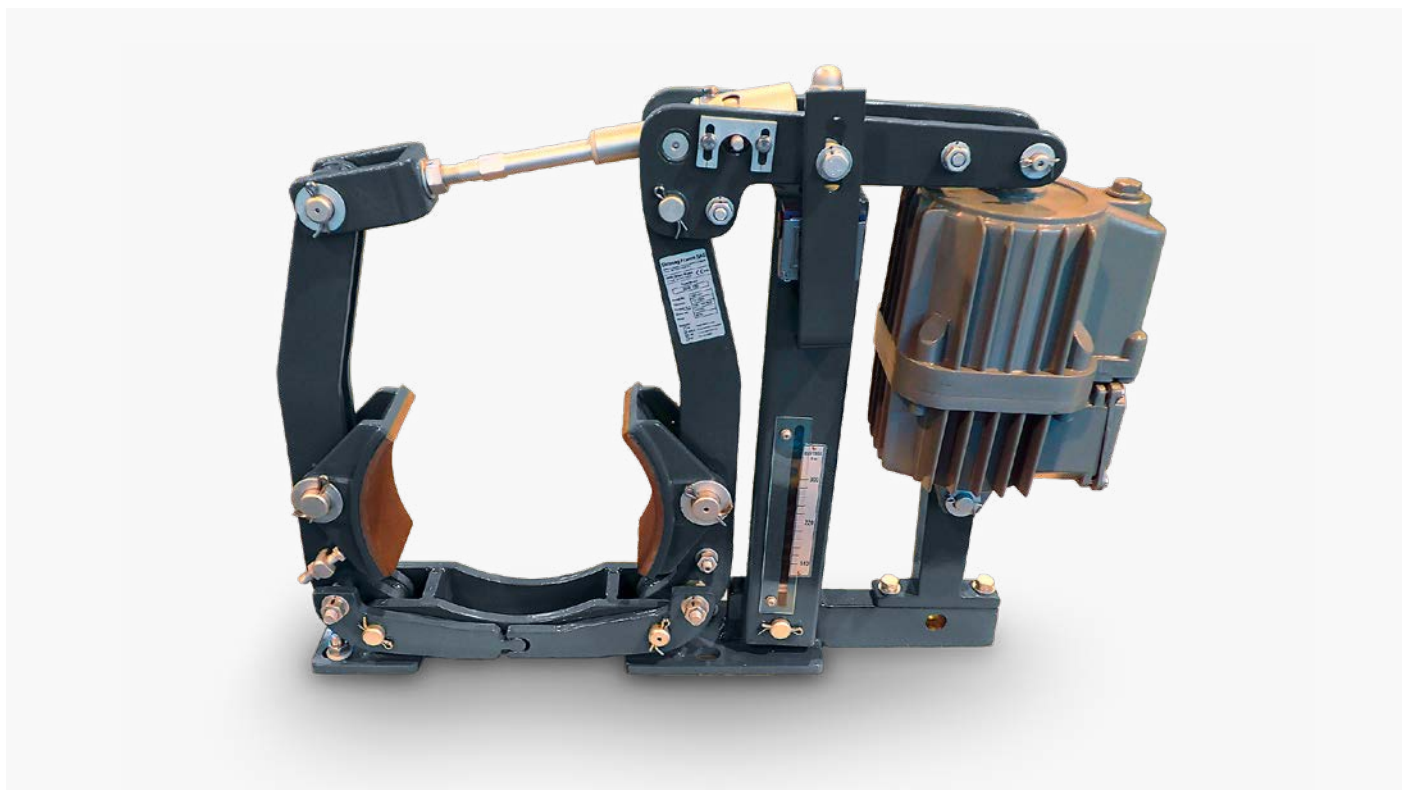

#### Options :

<b>AV - DV</b>	Thrustor delay : Ascent Valve or Descent Valve
<b>BRLS</b>	Switch for opening monitoring
<b>HRL</b>	Hand release lever with or without stop
<b>HRLM</b>	Switch for hand release monitoring
<b>LWI</b>	Full lining wear indicators
<b>SPA</b>	Paint according to Customer Specification
<b>SV</b>	Special Voltage

#### Thrustor Technical Data :

Thrustor type	Power (W)	Current at 400 V (A)	Weight (kg)
<b>TS 230/5</b>	200	0.5	14
<b>TS 300/5</b>	200	0.5	14
<b>TS 500/6</b>	210	0.5	23
<b>TS 800/6</b>	330	1.2	24
<b>TS 1210/6</b>	330	1.2	39
<b>TS 2010/6</b>	450	1.3	39
<b>TS 3010/6</b>	550	1.4	40

### DRUM BRAKE - SAB BRAKES

Revision number: T10110-02-F

Revision date: 13.02.2020

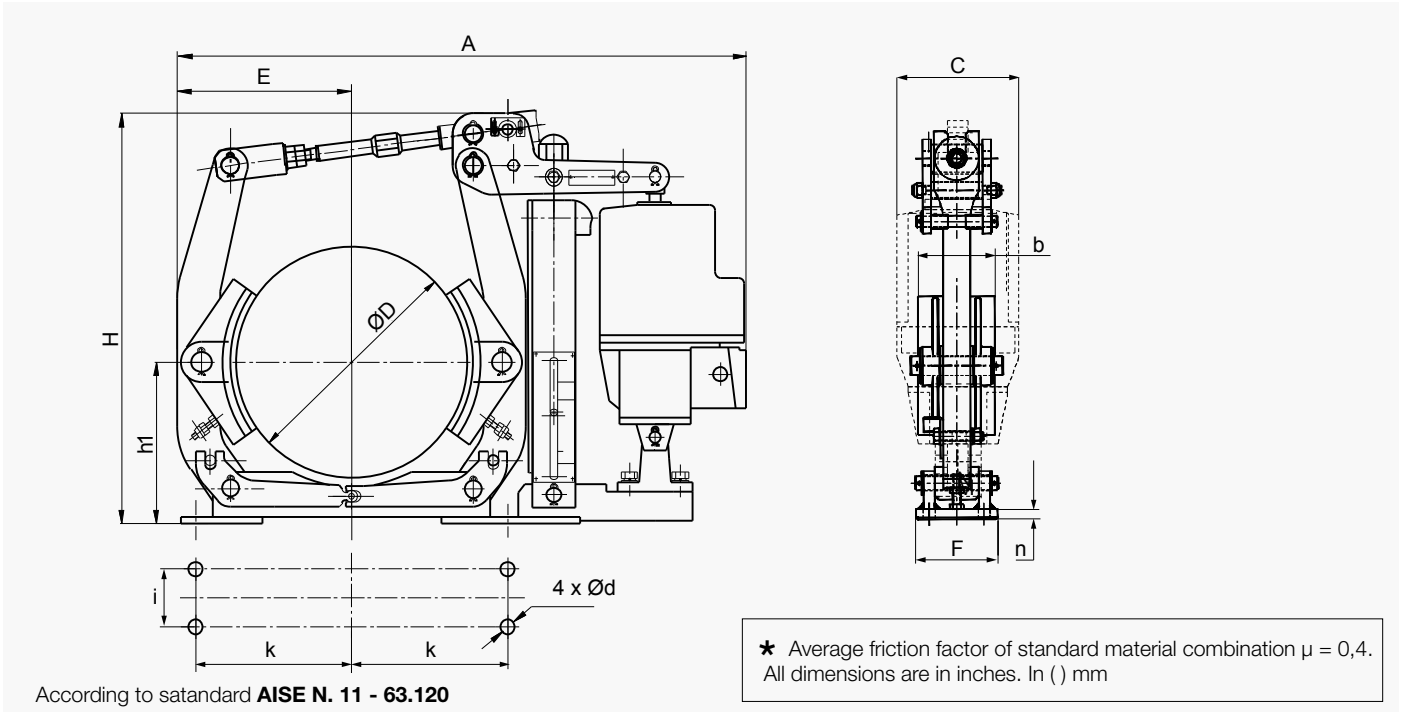

Brake Type	Thrustor TS	$M_{BR\ MAX}$ (lb-ft) *	A	b	C	D	d	E	F	H	h1	i	k	n	WEIGHT (lb)
SAB - 6"	230/5	55-110	17	1.65	6.3	6 (152)	3/8 (9.5)	5.5	7.25	16.5	4.75 (120)	3 (76)	4 (102)	0.38	70
SAB - 8"	230/5	85-190	26.00	3.00	6.3	8 (203)	0.69 (17)	6.77	7.25	20	7.0 (178)	5.76 (146)	3.25 (83)	0.31	77
	300/5	140-275													84
SAB - 10"	230/5	110-220	30.30	3.54	6.3	10 (254)	0.69 (17)	7.95	8.00	23.2	8.38 (213)	6.26 (160)	4.0 (102)	0.60	100
	300/5	140-280	106												
	500/6	220-440	116												
SAB - 12"	300/5	170-345	37.00	5.51	6.3	12 (305)	0.81 (21)	10.40	11.00	23.4	9.88 (251)	9.0 (228)	5.75 (146)	0.60	155
	500/6	270-540													164
	800/6	430-855													176
SAB - 13"	300/5	180-375	37.00	5.51	6.3	13 (330)	0.81 (21)	10.40	11.00	23.4	9.88 (251)	9.0 (228)	5.75 (146)	0.60	160
	500/6	295-590													164
	800/6	460-930													176
SAB - 15"	500/6	330-665	40.20	6.49	6.3	15 (381)	1.06 (27)	12.20	13.25	28.4	12.13 (308)	10.76 (273)	7.5 (191)	0.60	300
	800/6	515-1030													308
	1210/6	840-1675													335
SAB - 16"	500/6	355-710	40.20	6.49	7.7	16 (406)	1.06 (27)	12.20	13.25	28.4	12.13 (308)	10.76 (273)	7.5 (191)	0.60	304
	800/6	550-1110													308
	1210/6	900-1800													335
SAB - 19"	800/6	665-1330	49.00	8.50	7.7	19 (483)	1.06 (27)	15.00	16.20	31.9 32.7	13.25 (337)	13 (330)	9.25 (235)	0.79	445
	1210/6	1055-2110													455
	2010/6	1700-3390													455
SAB - 23"	1210/6	1220-2440	63.40	10.98	9.45	23 (584)	1.31 (33)	17.50	18.75	41.0	15.88 (403)	16 (406)	11.75 (298)	0.79	695
	2010/6	1900-3870													695
	3010/6	2850-5760													705
	3010/12	3450-6900													705
SAB - 30"	1210/6	1400-2800	68.00	14.01	9.45	30 (762)	1.56 (40)	21.50	23.00	44.5	20.75 (527)	19 (482)	15.0 (381)	1.18	950
	2010/6	2360-4720													950
	3010/6	3650-7370													950
	3010/12	4400-8800													950

# SIME Brakes Industrial Braking Systems

## Service Brakes

### DRUM BRAKE - FNS-VS 160 TO 400 BRAKES

Revision number: T03109-01-E

Revision date: 27.07.2016

#### Standard DIN 15435

Spring application  
 Thrustor release  
 Protection level : C3M  
 Voltage : 230 / 400V 50 Hz  
 Other voltages, consult us.

**AT** High temperature  
**BT** Low temperature  
**ATEX** Certificat ATEX / Thrustor  
**BI** Stainless steel bolts  
**CSA** Opening proving switch  
**DD** Lining wear indicators  
**DM** Hand release lever

**LM** Locking lever to hold the brake open  
**PE** Special paint : color / > C3M  
**PL** Padlock for the locking lever  
**PR** Reduced torque  
**RA** Automatic lining wear compensation  
**VD** Descent valve  
 Brake not fitted with the thrustor

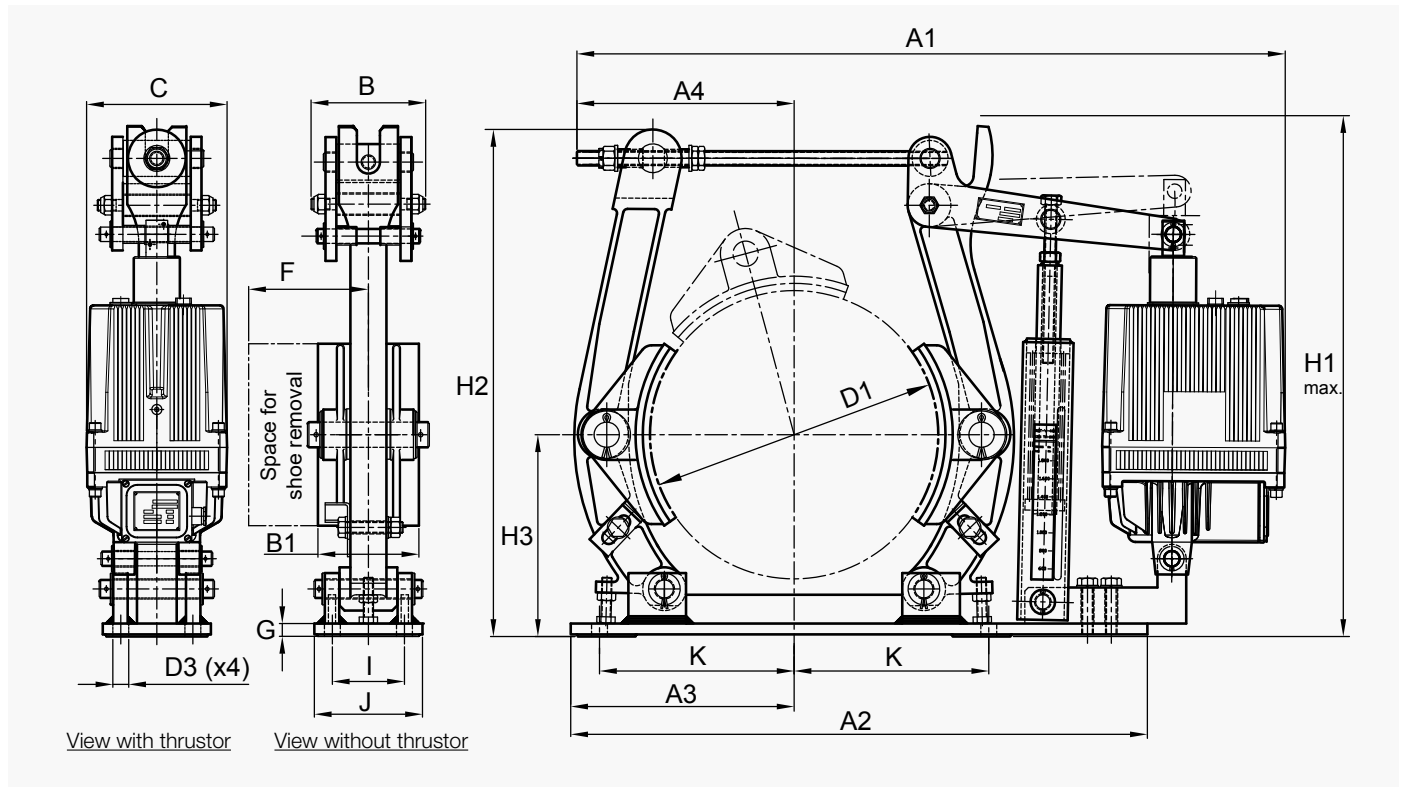

BRAKE TYPE	THRUSTOR VS	TORQUE N.m.		WEIGHT kg	DRUM WIDTH	SHOE WIDTH B1	DIMENSIONS																
		min.	max.				D1	D3	H3	I	K	A1	A2	A3	A4	B	C	F	G	H1	H2	J	
160	I-256	118	235	28	60	65	160	11	130	55	120	614	420	140	177	116	160	110	20	424	364	90	
200	I-256	125	250	29	75	70	200	14	160	55	145	664	510	185	178	116	160	125	19	405	355	90	
	I-356	188	375	34								674								497			
250	I-256	128	255	35	95	90	250	18	190	65	180	710	580	220	210	116	160	130	13	425	413	100	
	I-356	235	470	40								760								499			
315	I-356	275	550	59	118	110	315	18	230	80	220	769	690	260	223	159	195	180	18	595	588	120	
	II-506	438	875	62								820								620			
400	II-806	700	1400	63	150	140	400	22	280	100	270	820	800	310	307	159	195	210	18	635	710	704	150
	II-506	450	900	85								980								710			
	II-806	760	1520	87								990								710			
	III-1306	1350	2700	107								975				164	240			775			

For higher torque, please consult us. Some types may present little differences in the form with the drawing



### DRUM BRAKE - FNS-VS 500 TO 710 BRAKES

Revision number: T03109-01-E

Revision date: 27.07.2016

#### Standard DIN 15435

Spring application  
 Thrustor release  
 Protection level : C3M  
 Voltage : 230 / 400V 50 Hz  
 Other voltages, consult us.

- |             |                            |           |                                      |
|-------------|----------------------------|-----------|--------------------------------------|
| <b>AT</b>   | High temperature           | <b>LM</b> | Locking lever to hold the brake open |
| <b>BT</b>   | Low temperature            | <b>PE</b> | Special paint : color / > C3M        |
| <b>ATEX</b> | Certificat ATEX / Thrustor | <b>PL</b> | Padlock for the locking lever        |
| <b>BI</b>   | Stainless steel bolts      | <b>PR</b> | Reduced torque                       |
| <b>CSA</b>  | Opening proving switch     | <b>RA</b> | Automatic lining wear compensation   |
| <b>DD</b>   | Lining wear indicators     | <b>VD</b> | Descent valve                        |
| <b>DM</b>   | Hand release lever         |           | Brake not fitted with the thrustor   |

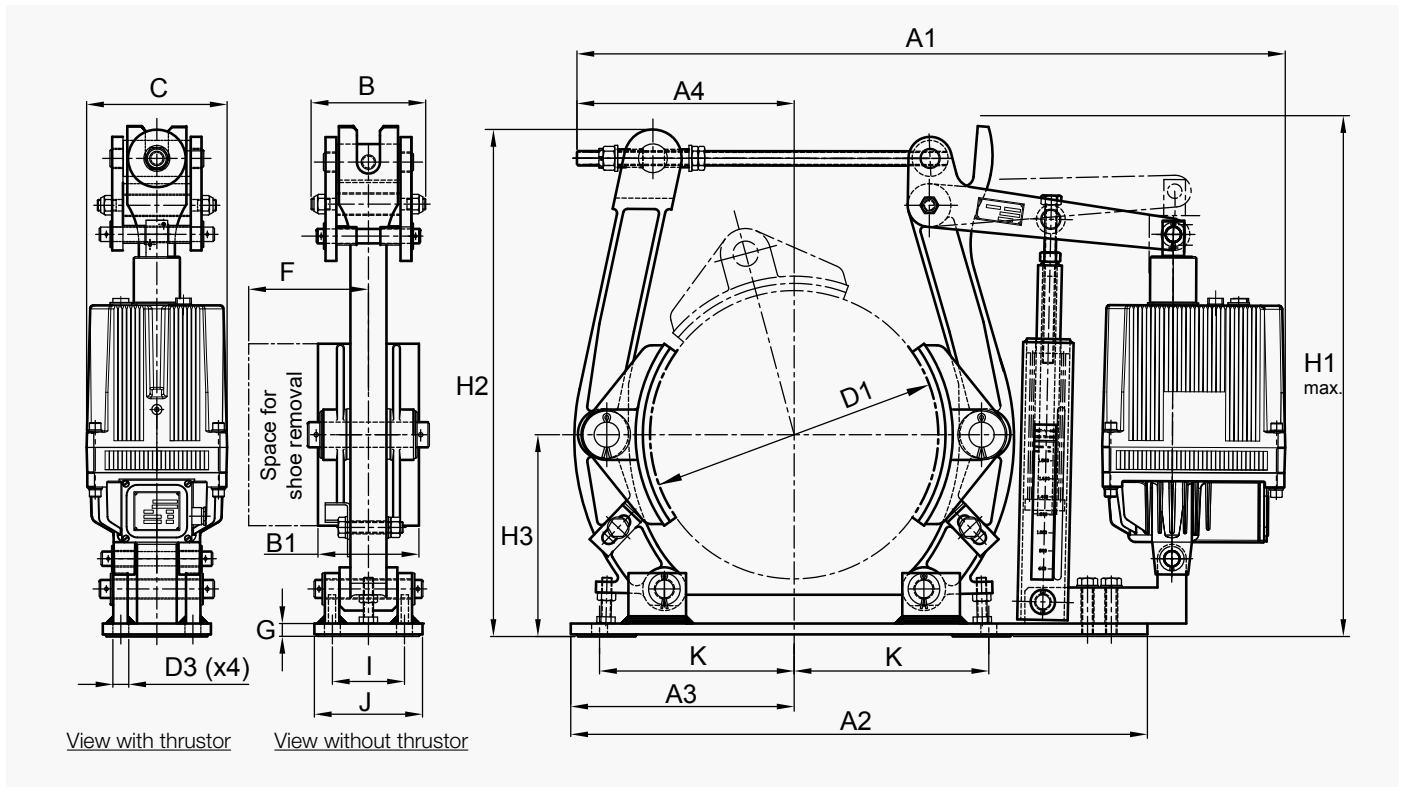

BRAKE TYPE	THRUSTOR VS	TORQUE N.m.		WEIGHT kg	DRUM WIDTH	SHOE WIDTH B1	DIMENSIONS															
		min.	max.				D1	D3	H3	I	K	A1	A2	A3	A4	B	C	F	G	H1	H2	J
500	II-806	800	1600	125	190	180	500	22	340	130	325	1039	940	365	312	195	250	23	820	803	180	
	III-1306	1325	2650	145								1060			240	240						
	III-2006	2125	4250	147								1060			240	240						
630	III-1306	1450	2900	240	236	225	630	27	420	170	400	1240	1150	460	435	230	240	305	23	955	940	220
	III-2006	2325	4650	242								1240			435							
	III-3006	3725	7450	244								1240			435							
	III-3012	3875	7750	258								1325			427							
710	III-2006	2875	5750	323	265	255	710	27	470	190	450	1405	1280	510	470	250	240	340	29	1085	1067	250
	III-3006	4300	8600	324								1405										
	III-3012	4950	9900	338								1570										

For higher torque, please consult us. Some types may present little differences in the form with the drawing

# SIME Brakes Industrial Braking Systems

## Service Brakes

### APPLICATIONS

- PORT CRANES
  - ALL HOISTING APPLICATIONS
  - TRAVELLING CONTROL
  - MASS TRANSPORT
- STEEL CRANES :  
CHARGING AND LADDLE CRANES  
SLAG AND SCRAP CRANES
  - BELT CONVEYORS - MINES

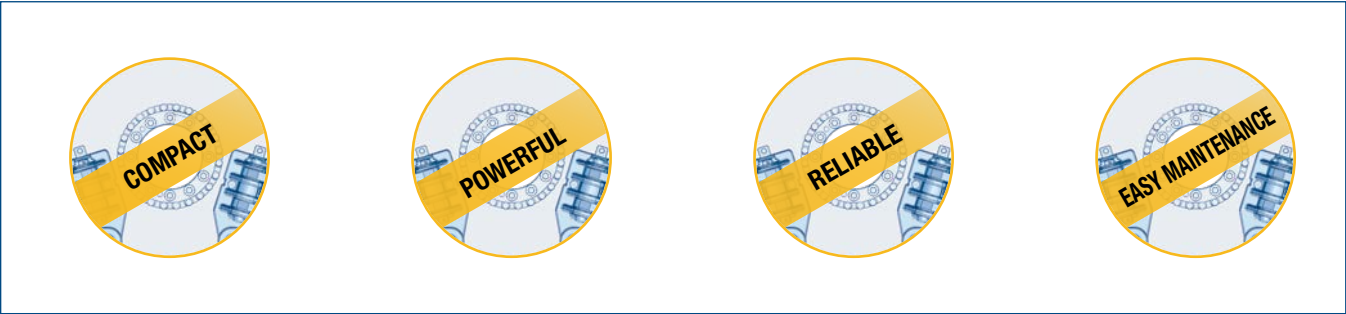

# HYDRAULIC SERVICE BRAKES

MAIN CHARACTERISTICS	OPTIONS
<ul style="list-style-type: none"> <li>• FAILSAFE BRAKES</li> <li>• BRAKING BY HYDROSPRING® SYSTEM</li> <li>• INTEGRAL ELECTRICAL CONNECTIONS</li> <li>• INTEGRAL HYDRAULICAL CONNECTIONS</li> <li>• AUTOMATIC WEAR COMPENSATION</li> </ul>	<ul style="list-style-type: none"> <li>• ADJUSTABLE DELAY OF BRAKE CLOSING</li> <li>• MARINE PROTECTION</li> </ul>

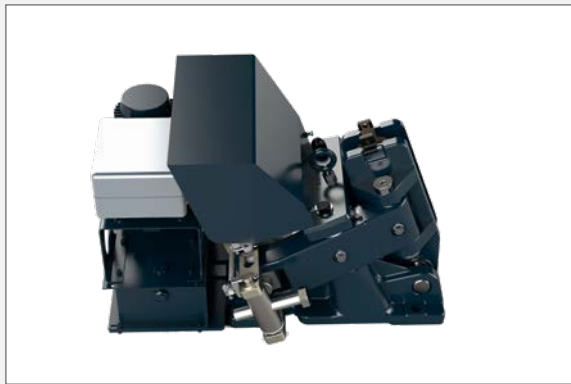

**2TB - 3TB - 4TB**

- Association with discs Ø445 to 995
- Options:
  - Torque setting
  - Controlled braking torque /stepped braking torque
  - Protective cover



**1TSA - 1TXA**

- Association with discs Ø625 to 995
- Torque setting

**Braking torque (kN.m)**

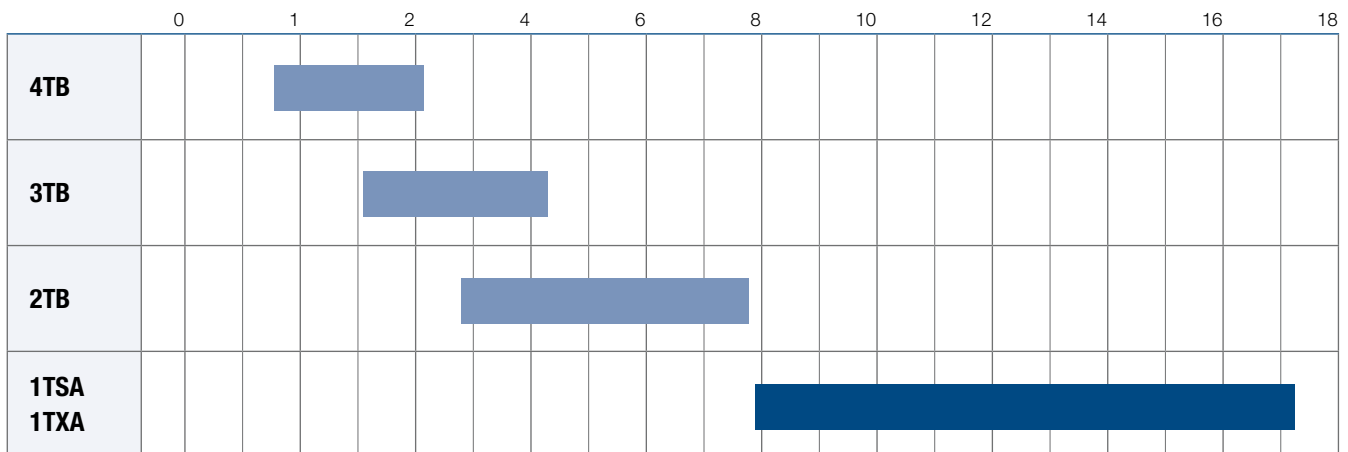

# SIME Brakes Industrial Braking Systems

## Service Brakes

### DISC BRAKE - 1TSA AND 1TXA CALIPERS

Revision number: T03681-01-A

Revision date: 15.02.2007

Fail safe  
Braking by HYDROSPRING® system  
Electrico-hydraulically released  
Integral hydraulic power unit  
Self contained electrical system  
Lining wear compensation  
Opening proving switch  
Torque setting

**Operating conditions :**

- Ambient temperature : -10° C to +50° C
- Relative humidity ≤ 70%
- Dust in atmosphere ≥ 65µ
- Other conditions, consult us.

**• 1TXA:**

Mounting of 2 calipers per disc, consult us.

**Options:**

- Linings with wear detection
- Adjustable delay brake closing system from 0.25 to 20 sec.
- Switch for PLC
- Marine protection

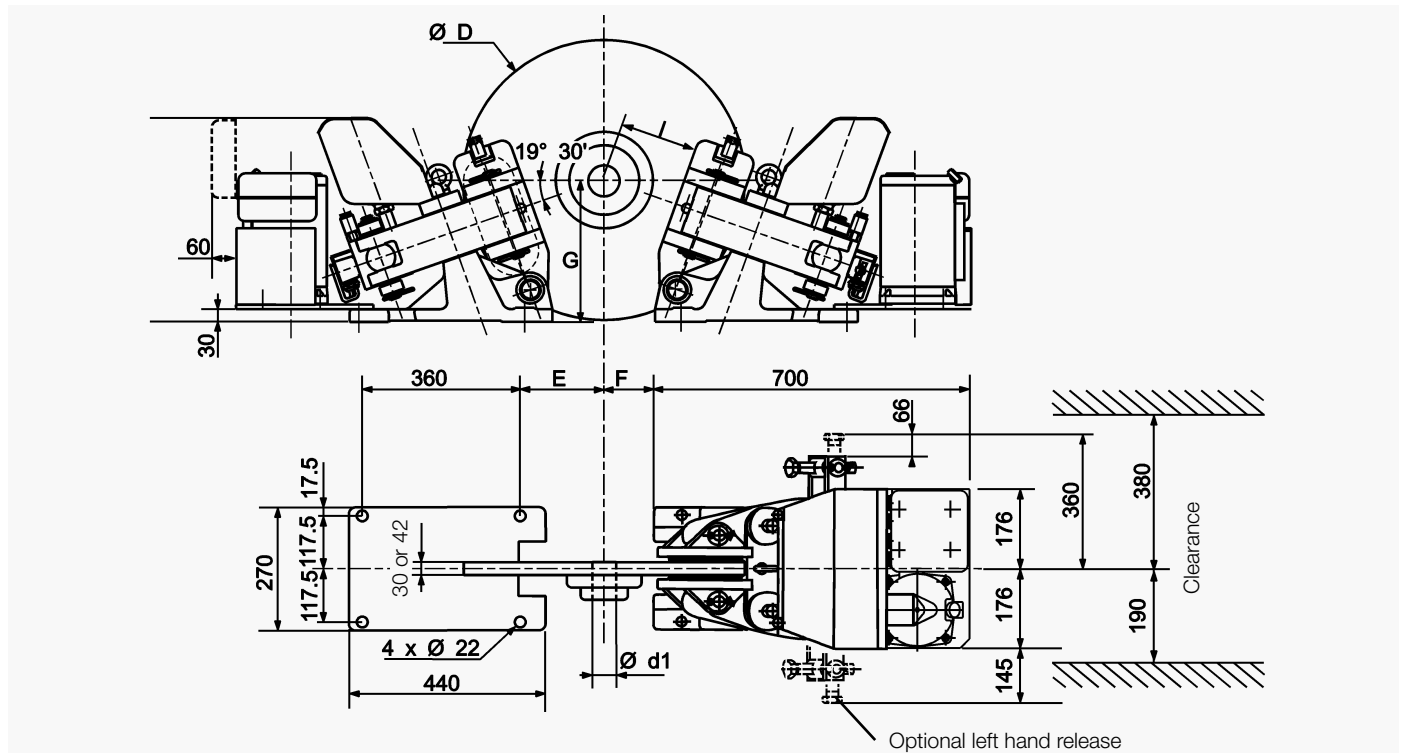

Weight: 160 kg

Response time at nominal torque ≤ 0.25 sec.

Caliper inclination from horizontal ± 15° maxi.

Other inclination, consult us.

Disc	Ø	mm	625		705		795		995		
			Thickness	mm	30	42	30	30	42	42	
Nominal torque for 1 caliper	<b>1TSA</b>	N.m	7920	9180	10620	14040					
	<b>1TXA</b>	N.m	9780	11300	13100	17300					
Disc speed for the nominal torque *		r.p.m.	≤ 1500	≤ 1300	≤ 1200	≤ 900					
<b>D</b>		mm	625	705	795	995					
<b>E</b>		mm	185	225	265	365					
<b>F</b>		mm	125	165	205	305					
<b>G</b>		mm	315	330	345	380					
<b>I</b>		mm	180	225	265	370					
<b>1TSA</b>											
Ø d <sub>1</sub> min. for:	1 caliper (1 key) ○	mm	97	97	100	111	111	130			
	2 calipers (2 keys) ●	mm	--	120	--	--	135	170			
<b>1TXA</b>											
Ø d <sub>1</sub> min. for:	1 caliper (1 key)	mm	104	104	111	125	125	145			
	1 caliper (shrink fit)	mm	104	104	107	110	110	118			
Maximum reaction on shaft:	1TSA ■	N					32 400				
	1TXA	N					40 000				

**Electric data :**

- 3 phases AC supply
- Voltages :  
230V / 400V ±10% 50Hz  
415V ±5% 50Hz  
460V ±5% 60Hz
- Maximum consumption: 775 W
- Electrical casing: IP 55  
DC supply, other voltages and conditions: consult us.
- Opening proving switch:  
240V, 3A, 10VA AC  
250V, 0.3A, 10W DC

\* For higher speed, consult us.

○ or shrink fit

■ Mounting with 2 calipers: multiply by 0.6

### DISC BRAKE - 2TB, 3TB AND 4TB CALIPERS

Revision number: T03664-01-C

Revision date: 24.08.2012

Fail safe  
Braking by HYDROSPRING® system  
Electrico-hydraulically released  
Integral hydraulic power unit  
Self contained electrical system  
Lining wear compensation  
Opening proving switch

**Operating conditions:**

- Ambient temperature : -10°C to +50°C
- Relative humidity ≤ 70%
- Dust in atmosphere ≥ 65µ
- Other conditions, consult us.

**Options:**

- Torque setting
- Detection of full lining wear
- Adjustable delay brake closing system from 0.25 to 20secs
- Controlled braking torque \*\*
- Marine protection
- Protective cover K
- Stepped braking torque \*\*
- Redundant circuit with 2 solenoid valves

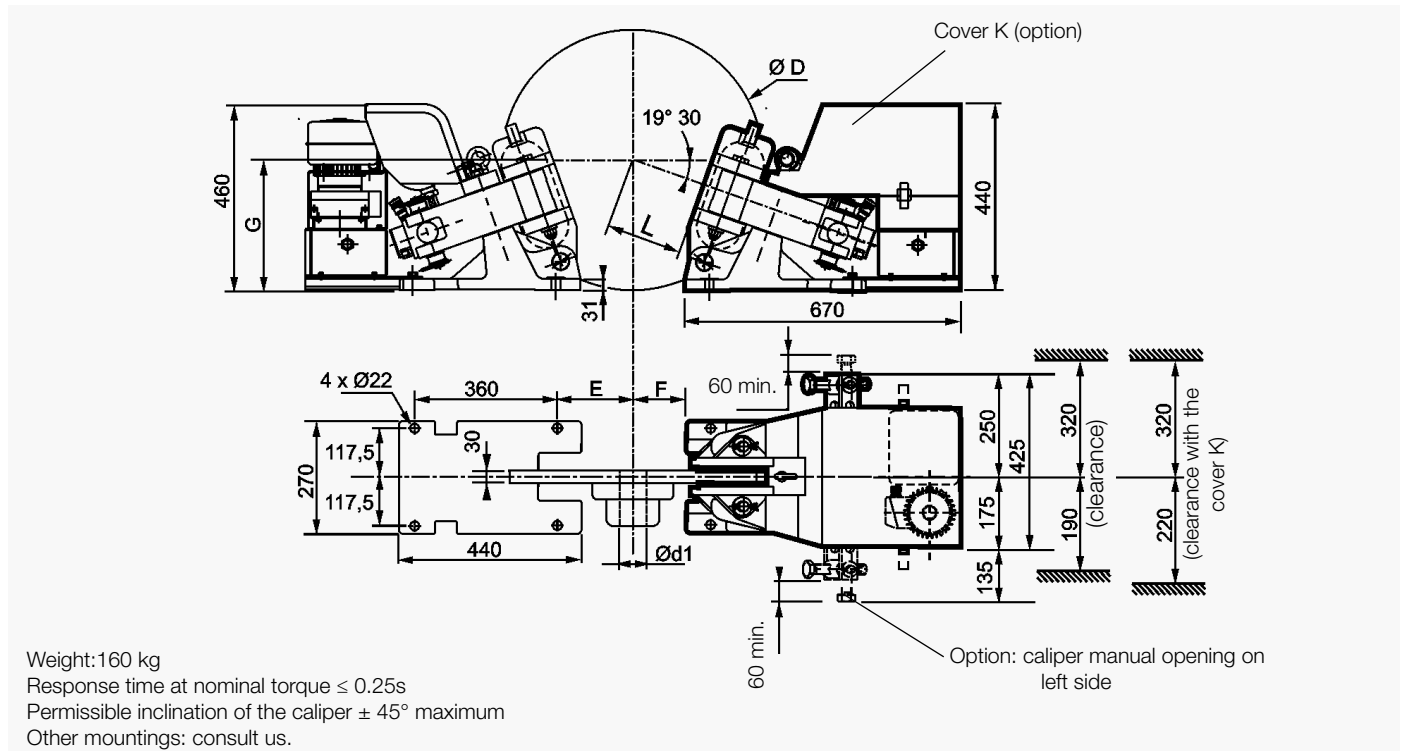

Weight: 160 kg  
Response time at nominal torque ≤ 0.25s  
Permissible inclination of the caliper ± 45° maximum  
Other mountings: consult us.

Discs			445	495	550	625	705	795	995	
Nominal torque for 1 caliper:	<b>2TB</b>	N.m	2800	3250	3700	4400	5100	5900	7800	
	<b>3TB</b>	N.m	1550	1800	2050	2450	2850	3250	4300	
	<b>4TB</b>	N.m	775	900	1030	1230	1430	1630	2150	
Maximum disc speed for nominal torque *		rpm	2100	1900	1800	1500	1300	1200	900	
D		mm	445	495	550	625	705	795	995	
E		mm	100	120	150	185	225	265	365	
F		mm	40	60	90	125	165	205	305	
G		mm	285	295	305	315	330	345	380	
L		mm	90	130	145	180	225	265	370	
d1 min. keyed for 1 caliper (steel St 70):	<b>2TB</b>	mm	73	75	77	80	82	87	92	
	<b>3TB</b>	mm	60	62	63	66	67	71	76	
	<b>4TB</b>	mm	48	49	50	52	53	57	58	
d1 min. keyed for 2 calipers (steel St 70):	<b>2TB</b>	mm	79	83	87	92	96	101	110	
	<b>3TB</b>	mm	65	68	71	75	79	82	91	
	<b>4TB</b>	mm	53	55	57	60	63	66	69	
Maximum reaction on shaft ■:	<b>2TB</b>	N							18000	
	<b>3TB</b>	N							10000	
	<b>4TB</b>	N							5000	

**Electric data:**

- Power unit motor:  
3 phases:  
230/400 V ±10%, 50 Hz,  
0.37 kW, 4 poles  
for mains:  
230/400 V 50 Hz  
or 415 V 50 Hz  
or 460 V 60 Hz
- Options motor:  
400/690 V ±10% 50Hz  
255/440 V ±10% 50Hz  
290/500 V ±10% 50Hz  
280/480 V ±10% 60Hz  
330/575 V ±10% 60Hz
- Other voltages, consult us.
- Electrical casing IP55
- Opening switch:  
240 V, 3 A, 10 VA AC  
250 V, 0.3 A, 10 W DC

■ Mounting with 2 calipers, multiply by 0.6

\* For higher speeds, consult us.  
\*\* Increased dimensions, consult us.

# SIME Brakes Industrial Braking Systems

## Service Brakes

### APPLICATIONS

- PORT CRANES
- HOIST, GANTRY AND TROLLEY MOTIONS
- BELT CONVEYORS
- MINES
- IRON AND STEEL INDUSTRY
- LADLE CRANES

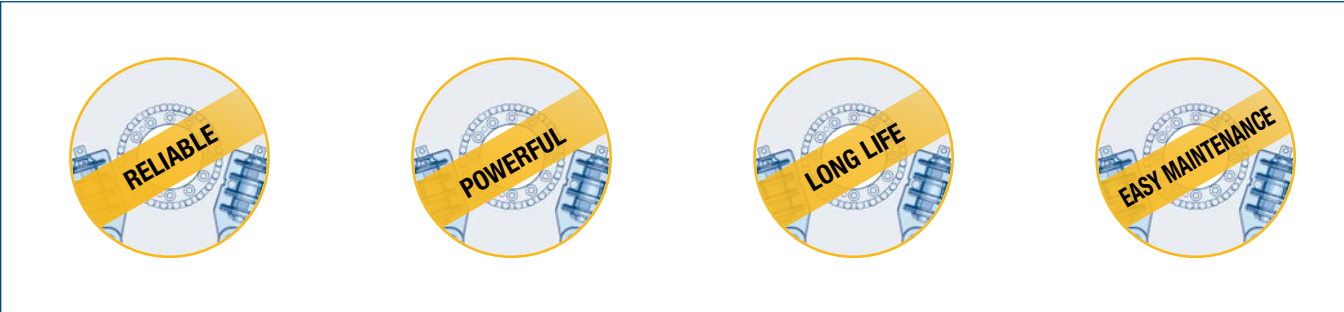

# THRUSTOR SERVICE BRAKES

MAIN CHARACTERISTICS	OPTIONS
<ul style="list-style-type: none"> <li>• FAILSAFE BRAKES</li> <li>• SPRING APPLIED</li> <li>• ELECTROHYDRAULIC THRUSTOR RELEASED</li> <li>• ADJUSTABLE BRAKING TORQUE</li> </ul>	<ul style="list-style-type: none"> <li>• LINING FULL WEAR CONTROL SWITCH</li> <li>• HIGH TEMPERATURE STEEL WORKS (SIDHT)</li> <li>• HIGH TEMPERATURE THRUSTOR (HT)</li> </ul>



**TDXB.I - TDXB.II**

- Lining wear automatic compensation
- Self-centering • Manual release lever
- Opening proximity switch
- Options:  
Closing and thrustor stroke proximity switches



**FAV10 - FAV15 - FAV21 - FAV40 - FAV50**

- Lining wear automatic compensation
- Auto centering
- Thrustor stroke and opening proving switches
- Options: Monitoring module

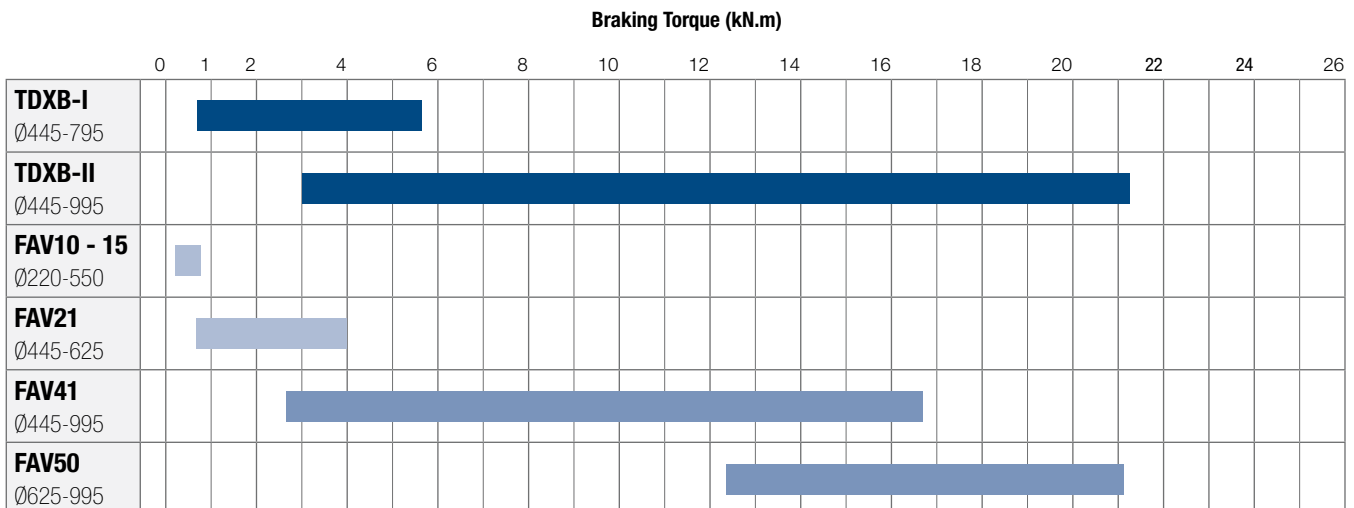

# SIME Brakes Industrial Braking Systems

## Service Brakes

### DISC BRAKE - TDXB-I BRAKE

Revision number: T10121-01-F

Revision date: 11.03.2019

Fail safe

Spring application / Thrustor release

Self-centering

Automatic lining wear compensation

Opening sensor

Low maintenance Teflon bushes

Lining full wear indicators

Manual release lever

Lining pads with DIN shape / Thrustors **TS**

#### Operating conditions:

- Ambient temperature: -25°C to +50°C

- Relative humidity ≤ 70%

- Dust in atmosphere ≥ 65µ

Other conditions: consult us.

#### Use:

- Service brake

#### Options :

- Closing sensor

- Thrustor limit stroke sensor

- Thrustor **TS** with option :

- **SW**: Oil Shell HF-E-32 / High Temp. seals

- **SV**: Special Voltage

- Custom color

- Thrustor **VS**

- Inductive sensors DC-AC 24-240V 50/60 Hz

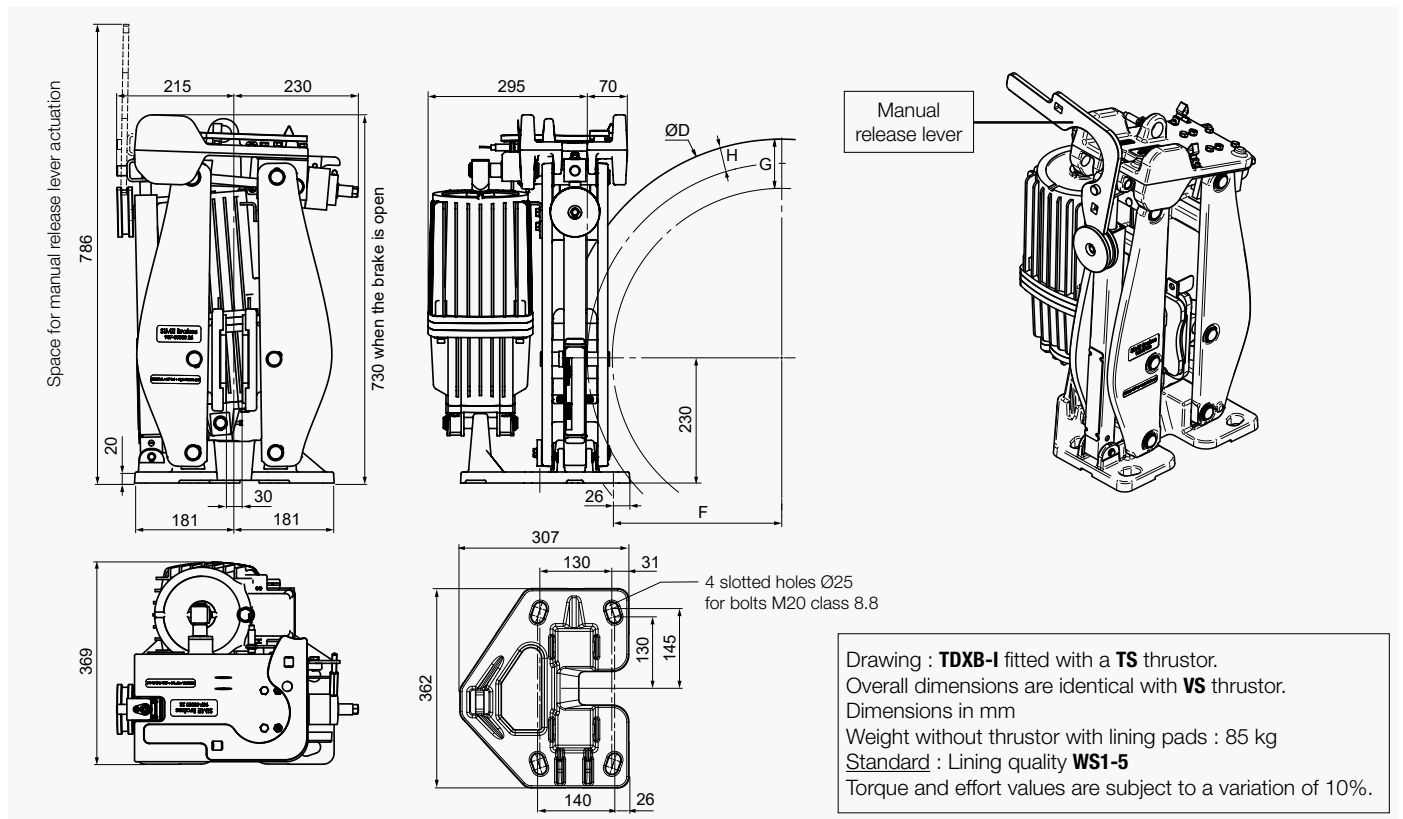

DISCS (ØD)			315	355	395	445	495	550	625	705	795
<b>NOMINAL TORQUE.</b> 1 caliper *	TDXB-I 1	N.m	901	996	1104	1267	1437	1619	1877	2148	2453
	TDXB-I 2	N.m	1490	1646	1826	2094	2374	2677	3102	3550	4054
	TDXB-I 3	N.m	2075	2293	2543	2917	3307	3728	4321	4945	5647
MAXIMUM DISC SPEED for nominal torque **		rpm	3000	2700	2400	2100	1900	1800	1500	1350	1200
Maximum linear speed		m/s	50								
<b>F</b>		mm	57	70	80	100	125	155	190	230	275
<b>G</b>		mm	56	59	70						
<b>H</b>		mm	28	30	35						
<b>MAXIMUM REACTION ON SHAFT</b>	TDXB-I 1	N					6776				
	TDXB-I 2	N					11200				
	TDXB-I 3	N					16000				

\* Nominal torque is adjustable from 100% to 70%

\*\* For higher speeds, consult Stromag France



### DISC BRAKE - TDXB-II BRAKE

Revision number: T10122-01-F

Revision date: 19.04.2019

Fail safe  
Spring application / Thrustor release  
Self-centering  
Automatic lining wear compensation  
Opening sensor  
Low maintenance Teflon bushes  
Lining full wear indicators  
Manual release lever  
Thrustors **TS**

**Operating conditions:**

- Ambient temperature: -25°C to +50°C
- Relative humidity ≤ 70%
- Dust in atmosphere ≥ 65µ
- Other conditions: consult us.

**Use:**

- Service brake

**Options :**

- Closing sensor
- Thrustor limit stroke sensor
- Thrustor **TS** with option :  
    **SW:** Oil Shell HF-E-32 / High Temp. seals  
    **SV:** Special Voltage
- Custom color
- Thrustor **VS**
- Inductive sensors DC-AC 24-240V 50/60 Hz

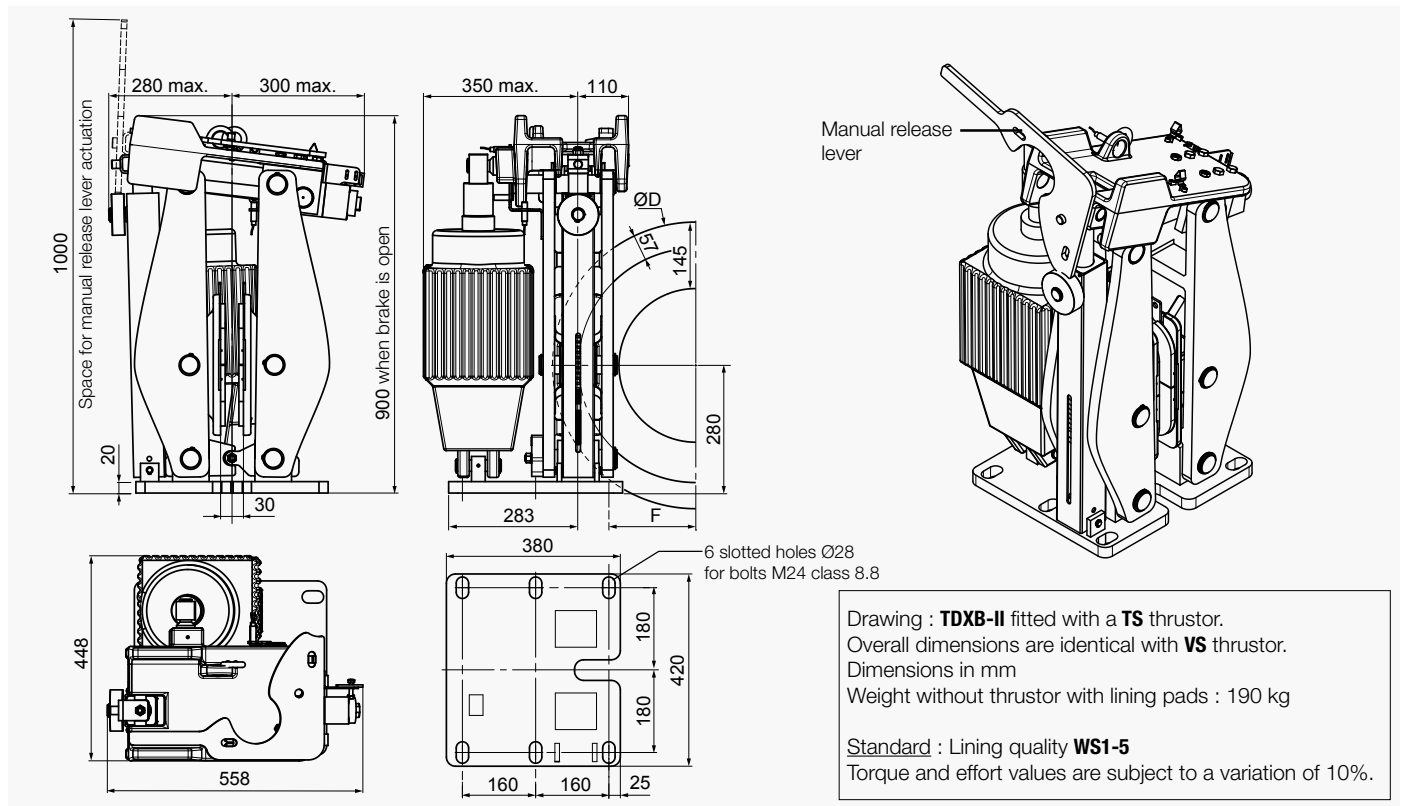

DISCS (ØD)			445	495	550	625	705	795	995
<b>NOMINAL TORQUE.</b> 1 caliper *	TDXB-II 1	N.m	4288	4928	5632	6592	7616	8768	11328
	TDXB-II 2	N.m	6030	6930	7920	9270	10710	12330	15930
	TDXB-II 3	N.m	8040	9240	10560	12360	14280	16440	21240
MAXIMUM DISC SPEED for nominal torque **		rpm	2100	1930	1740	1530	1354	1200	960
Maximum linear speed		m/s	50						
<b>F</b>		mm	93	118	145	183	255	268	368
		mm	D/2-129.5						
<b>MAXIMUM REACTION ON SHAFT</b>	TDXB-II 1	N	25600						
	TDXB-II 2	N	36000						
	TDXB-II 3	N	48000						

\* Nominal torque is adjustable from 100% to 70%

\*\* For higher speeds, consult Stromag France

# SIME Brakes Industrial Braking Systems

## Service Brakes

### DISC BRAKE - FAV10-FAV15 BRAKES

Revision number: T10022-01-I

Revision date: 23.05.2013

- Fail safe
- Spring application / Thrustor release
- Manual centering
- Lining wear compensation
- Linings with wear indicator wires
- Thrustor stroke control switch
- Opening proving switch
- Stainless steel pins
- Manual release lever
- Protection class C5 standard ISO12944-2

**Operating conditions:**

- Ambient temperature: -20°C to +50°C
- Relative humidity ≤ 70%
- Dust in atmosphere ≥ 65µ
- Other conditions: consult us.

**Use:**

- Service brake

**Options :**

- SIDHT : Steel works High Temperature
- HT : High Temperature Thrustor
- Thrustor :
- VS-I-256 or Ed23/5 - 230/400V (FAV10)
- VS-I-356 or Ed30/5 - 230/400V (FAV15)

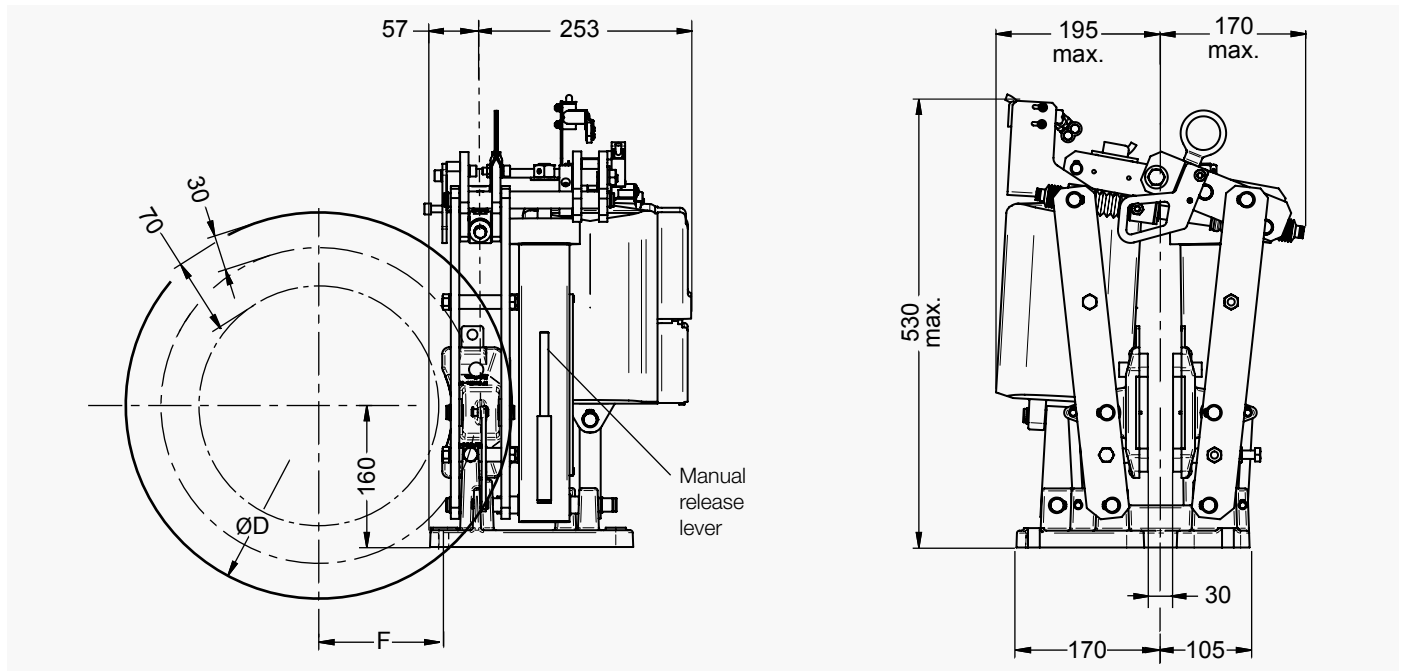

Weight without thrustor: 27 kg  
 Weight with thrustor : FAV10 : 40 kg. FAV15 : 44 kg  
 Torque and effort values are subject to a variation of ±10%

FAV10 and FAV15 calipers are associated with linings type **WS1-5**.

Discs (ØD)			220	260	315	355	395	445	495	550
Nominal torque. 1 caliper *	FAV10	N.m.	221	275	349	403	457	525	592	661
	FAV15	N.m.	265	330	410	485	550	630	710	795
Maximum disc speed for nominal torque **		rpm	4300	3600	3000	2700	2400	2100	1900	1800
F		mm	47	66	93	113	135	160	185	213
Maximum reaction on shaft	FAV10	N	2700							
	FAV15	N	3200							

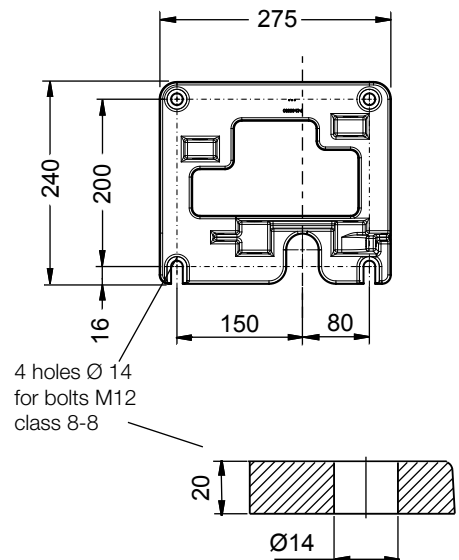

\* Braking torque is adjustable from 100% to 70% of nominal torque, friction factor  $\mu = 0.37$   
 \*\* For higher speeds, consult Stromag France

### DISC BRAKE - FAV21-VS BRAKE

Revision number: T10044-02-F

Revision date: 20.12.2019

Fail safe  
Spring application / Thrustor release  
Auto centering  
Lining wear compensation  
Thrustor stroke control switch  
Opening proving switch  
Manual release lever  
Stainless steel pins

**Operating conditions:**

- Ambient temperature: -20°C to +50°C
- Relative humidity ≤ 70%
- Dust in atmosphere ≥ 65µ

Other conditions: consult us

**Use:**

- Service brake

**Options :**

- Lining full wear control switch
- MSF : Monitoring modul for FAV
- SIDHT : High Temperature Steel works
- HT : High Temperature Thrustor
- Thrustors Ed50/6 - Ed80/6

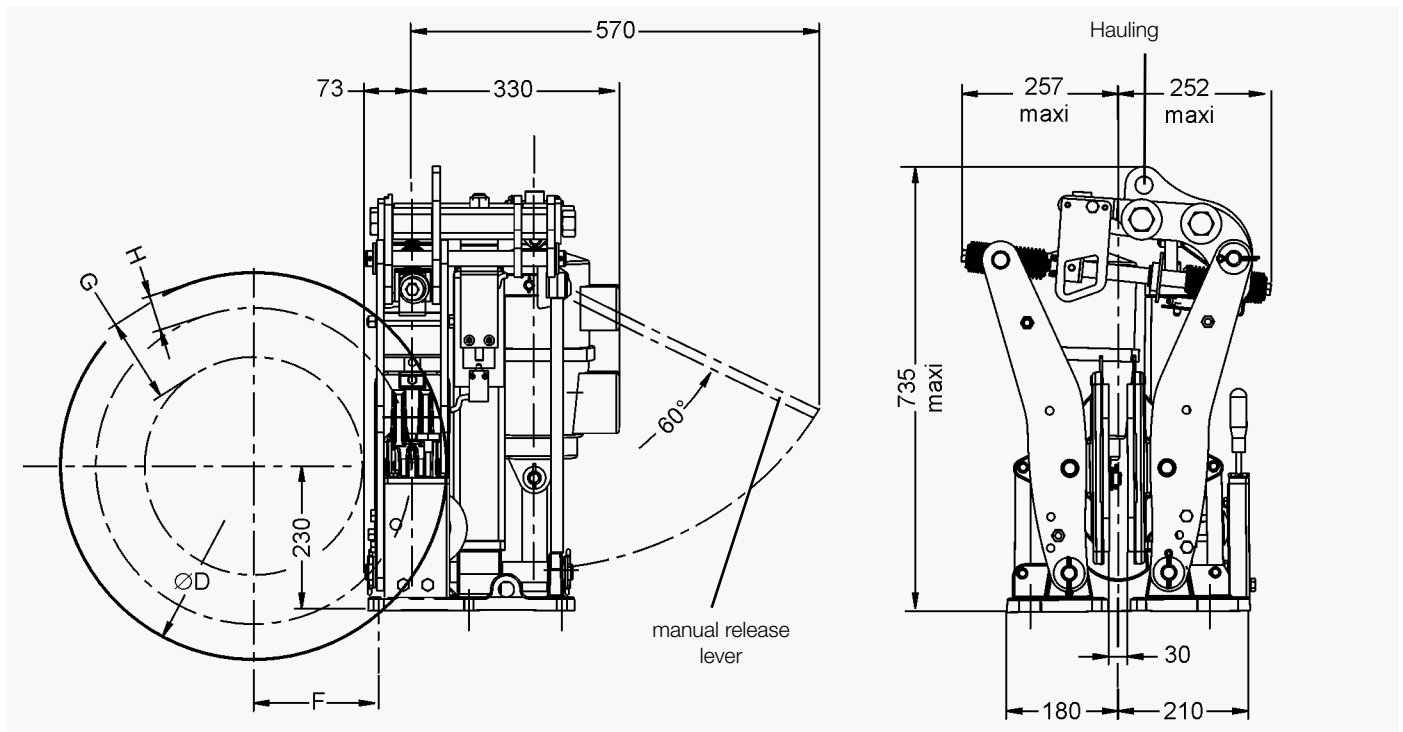

Weight with thrustor and lining pads : 130 kg  
Torque and effort values are subject to a variation of ±10%  
Lining quality **WS1-5** in standard.

Discs (ØD)		355	395	445	495	550	625	705	
Nominal torque *	<b>FAV213 VS II 1306</b>	N.m.	-	-	2260	2590	2990	3450	4000
	<b>FAV212 VS II 806</b>	N.m.	1300	1500	1700	1950	2250	2600	-
	<b>FAV211 VS II 506</b>	N.m.	700	750	900	1000	1150	1350	-
Max. disc speed for nominal torque **		rpm	2700	2400	2100	1900	1800	1500	1500
F		mm	122	142	118	143	170	208	248
F		mm	(D/2-56)		(D/2-105)				
G		mm	67		136				
H		mm	32		57				
Maximum reaction on shaft	<b>FAV213 VS II 1306</b>	N	-		13600				
	<b>FAV212 VS II 806</b>	N	9100		10200				-
	<b>FAV211 VS II 506</b>	N	4500		5300				-

\* Nominal torque is adjustable from 100% to 70%  
\*\* For higher speeds, consult Stromag France

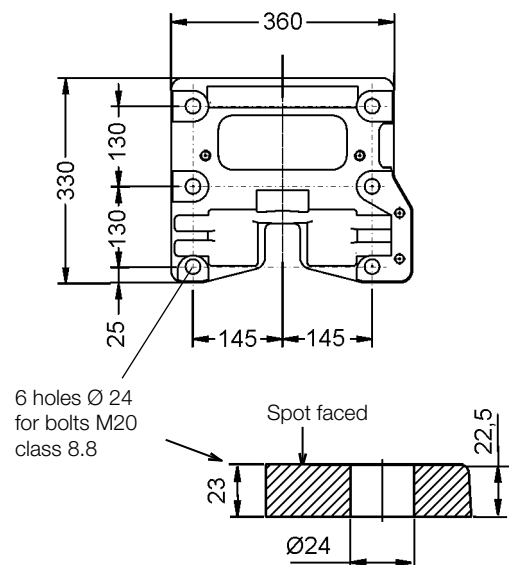

# SIME Brakes Industrial Braking Systems

## Service Brakes

### DISC BRAKE - FAV41-VS BRAKE

Revision number: T03524-02-D

Revision date: 08.11.2017

Fail safe  
Spring application / Thrustor release  
Auto centering  
Lining wear compensation  
Thrustor stroke control switch  
Opening proving switch  
Stainless steel pins  
Manual release lever for FAV411/412-VS  
Manual release system for FAV413-VS

**Operating conditions:**

- Ambient temperature: -20°C to +50°C
- Relative humidity ≤ 70%
- Dust in atmosphere ≥ 65µ

Other conditions: consult us

**Use:**

- Service brake

**Options :**

- Lining full wear control switch
- MSF : Monitoring modul for FAV
- SIDHT : High Temperature Steel works
- HT : High Temperature Thrustor
- Thrustors : Ed301/10 - Ed201/10 - Ed121/10

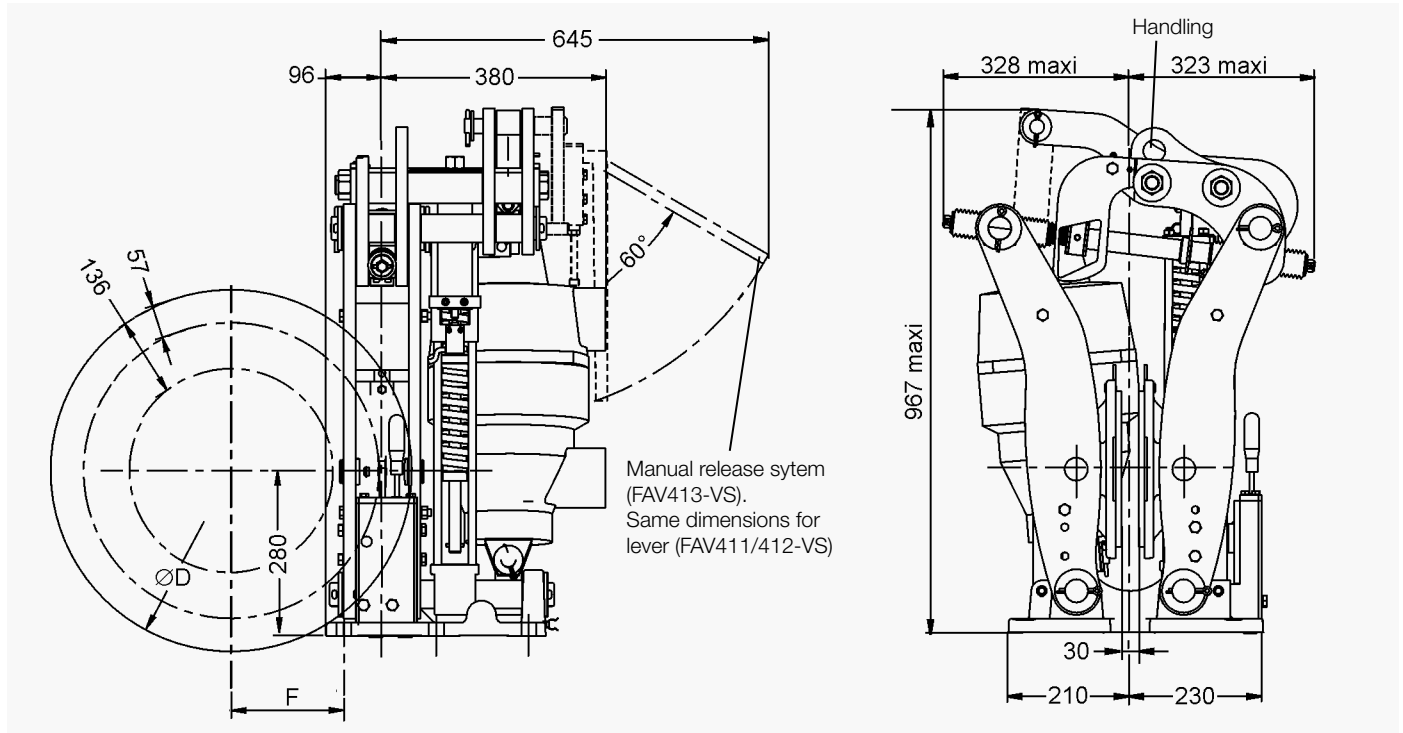

Weight without thrustor : 180 kg / Weight with thrustor : 222 kg  
Torque and effort values are subject to a variation of ±10%  
The disc run-out must not exceed 0.08 % of the maximum radius  
and the disc axial displacement must be smaller than 0.5 mm.  
Lining quality **WS1-5** in standard.

Discs (ØD)	445	495	550	625	705	795	995
<b>Nominal torque.</b>							
1 caliper * (N.m)	FAV413 VS-III-3010 2650	FAV412 VS-III-2010 4960 3050	FAV411 VS-III-1310 5650 3500	9700 6600 4100	11200 7650 4750	12950 8800 5450	16700 - -
Maximum disc speed for nominal torque (rpm) **	2100	1900	1800	1500	1300	1200	900
F (mm) ( F=D/2-130 )	93	118	145	183	223	268	368
<b>Maximum reaction on shaft (N)</b>				38000	26000	16000	
				FAV413 VS-III-3010	FAV412 VS-III-2010	FAV411 VS-III-1310	

2 threads M16  
(for on-site positioning)

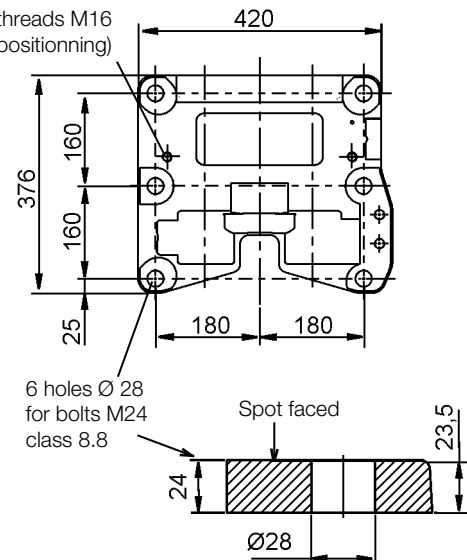

\* Nominal torque is adjustable from 100% to 70%  
\*\* For higher speeds, consult Stromag France

### DISC BRAKE - FAV50 / FAV50-VS BRAKES

Revision number: T03525-01-D / T03525-02-E

Revision date: 08.11.2017 / 08.11.2017

Fail safe  
Spring application / Thrustor release  
Auto centering  
Lining wear compensation  
Thrustor stroke control switch  
Opening proving switch  
Stainless steel pins  
Manual release system

**Operating conditions:**

- Ambient temperature: -20°C to +50°C
- Relative humidity ≤ 70%
- Dust in atmosphere ≥ 65µ

Other conditions: consult us.

**Use:**

- Service brake

**Options :**

- Lining full wear control switch
- MSF : Monitoring modul for FAV
- SIDHT : High Temperature Steel works
- HT : High Temperature Thrustor

**FAV50 :** Thrustor Ed-301/100  
**FAV50-VS :** Thrustor VS-III-3010

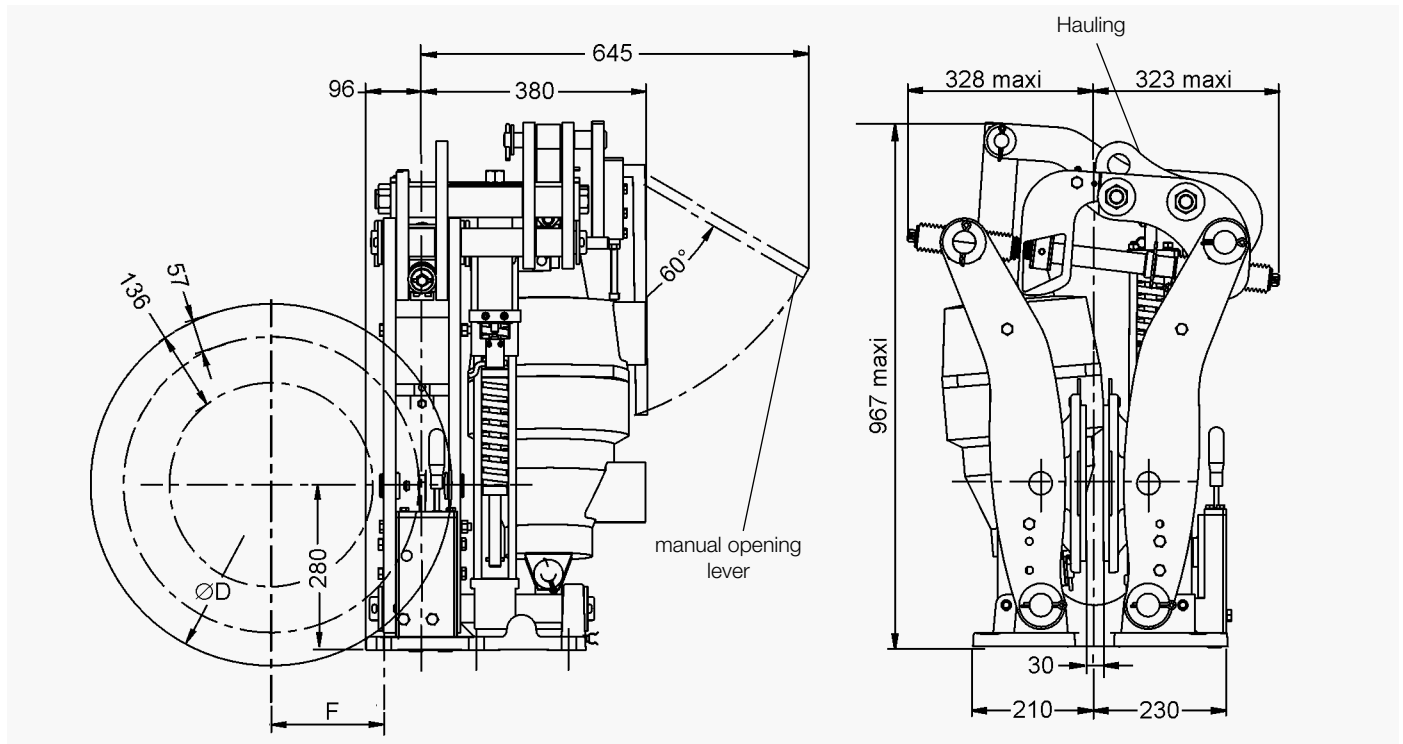

Weight without thrustor: 180 kg  
Weight with thrustor of **FAV503** : 220 kg. **FAV503-VS** : 224 kg.  
Torque and effort values are subject to a variation of ±10%  
Lining quality **WS1-5** in standard.

Discs (ØD)	625	705	795	995
<b>Nominal torque.</b> 1 caliper * <b>FAV503 / FAV503-VS</b> (N.m)	12360	14270	16500	21270
Maximum disc speed for nominal torque (rpm) **	1500	1300	1200	900
F (mm) ( F=D/2-130 )	183	223	268	368
<b>Maximum reaction on shaft (N)</b> <b>FAV503 / FAV503-VS</b>	48 400			

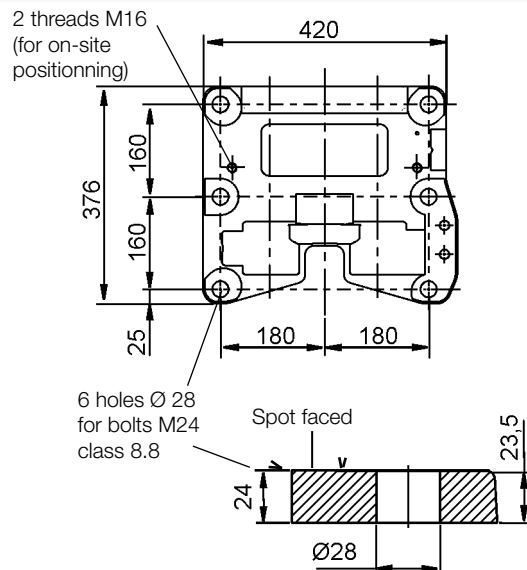

\* Nominal torque is adjustable from 100% to 70%  
\*\* For higher speeds, consult Stromag France

# SIME Brakes Industrial Braking Systems

## Emergency Brakes

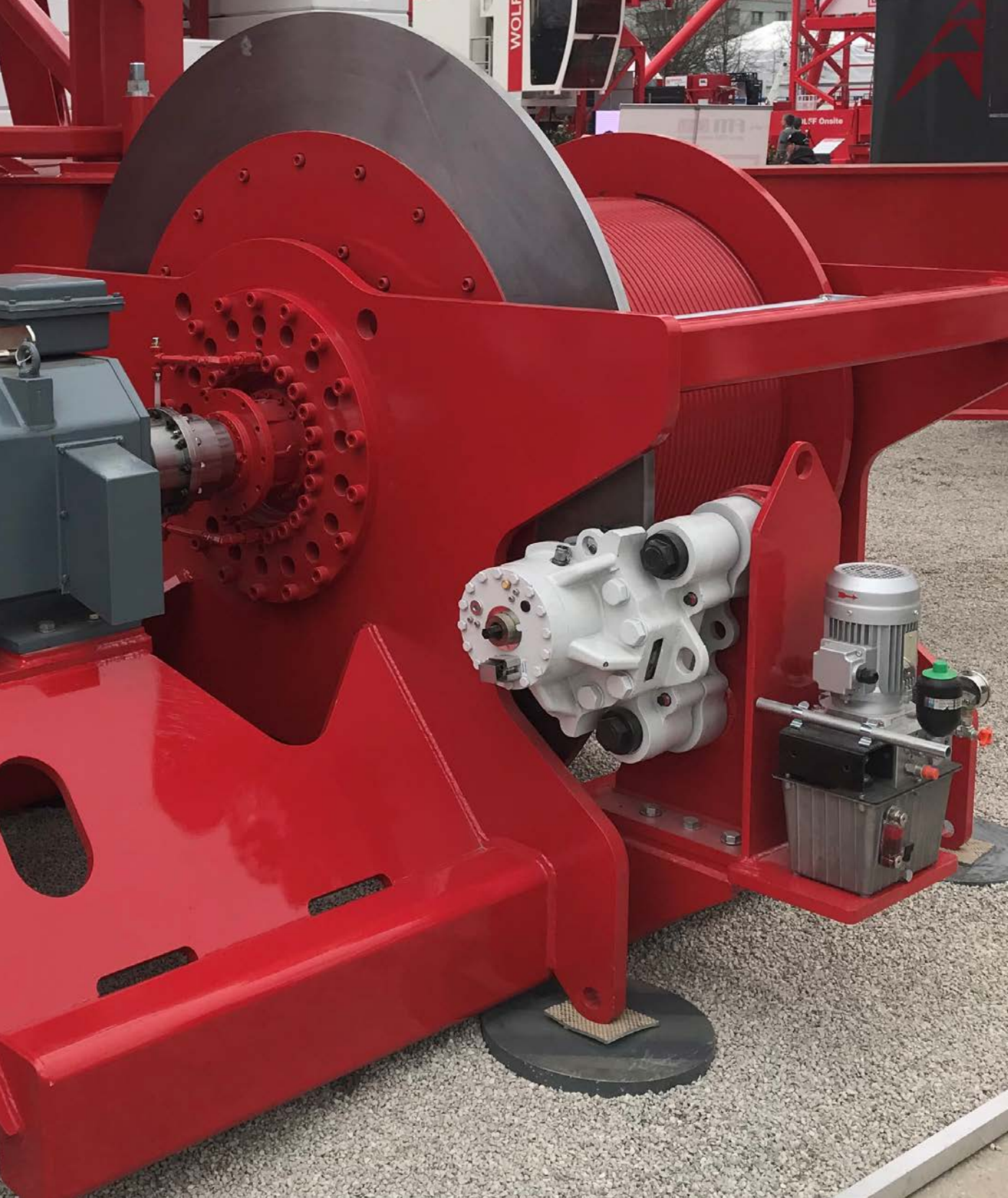

# EMERGENCY BRAKES



# SIME Brakes Industrial Braking Systems

## Emergency Brakes

ELECTROMAGNETIC BRAKES		Braking torque (kN.m)													
		0	5	10	20	40	60	80	100	150	200	250	300	350	
2SA OSA - OOSA															

HYDRAULIC BRAKES		Braking torque (kNm)													
		0	5	10	20	40	60	80	100	150	200	250	300	350	
SH-SHS-SHC disc Ø300 to 3000		Maxi. BT = 458 000 Nm (SH32 disc Ø 3000 mm)													
SHD disc Ø300 to 2000															
TH - THC disc Ø1000 to 2000															

### A COMPLETE BRAKING SOLUTION

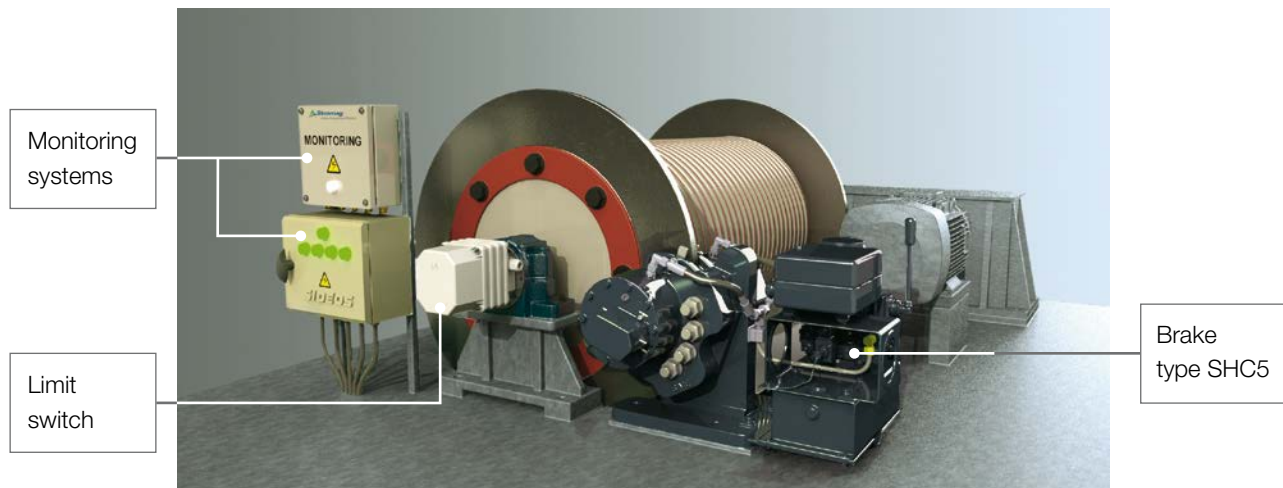

# SIME Brakes Industrial Braking Systems

## Emergency Brakes

### APPLICATIONS

- STEEL INDUSTRY
- NUCLEAR PLANTS



Four circular icons with yellow banners, each containing a technical drawing of a brake component and a key feature:

- COMPACT
- EASY MOUNTING
- RELIABLE
- EASY MAINTENANCE



# ELECTROMAGNETIC EMERGENCY BRAKES

MAIN CHARACTERISTICS	OPTIONS
<ul style="list-style-type: none"> <li>• FAILSAFE BRAKE BY SPRING APPLICATION</li> <li>• ELECTROMAGNETIC RELEASE</li> <li>• MANUAL LINING WEAR COMPENSATION</li> <li>• OPENING PROVING SWITCH</li> <li>• DETECTION OF FULL LINING WEAR</li> </ul>	<ul style="list-style-type: none"> <li>• LOAD REGULATED LOWERING</li> </ul>



**2SA**

Air gap switch



**OSA**

- Option :  
Manual release lever  
Hydraulic release  
Mounting on a vertical axis disc  
Flameproof / Marine protection...



**OOSA**

- Option :  
Manual release lever  
Hydraulic release  
Flameproof protection  
Marine protection

**Braking torque (kN.m)**

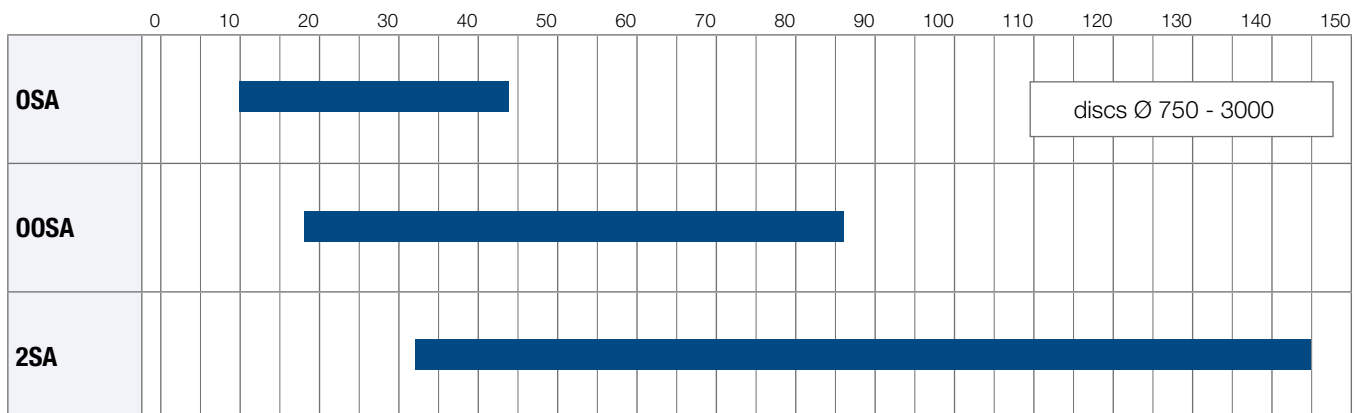

# SIME Brakes Industrial Braking Systems

## Emergency Brakes

### DISC BRAKE - OSA CALIPER

Revision number: T03750-01-F

Revision date: 22.03.2016

Fail safe braking  
Braking by spring application  
Electromagnetic release  
Manual lining wear compensation  
Detection of full lining wear  
Opening proving switch

**Operating conditions:**

- Ambient temperature: -10°C to +60°C
  - Relative humidity ≤ 70%
  - Dust in atmosphere ≥ 65µ
- Other conditions, consult us.

**Use:**

The brake should be applied only in case of emergency stop, overspeed or shutdown of electric mains.

**Options:**

- Manual release lever
- Hydraulic release
- Load regulated lowering
- Flameproof protection
- Marine protection
- Mounting on a vertical axis disc

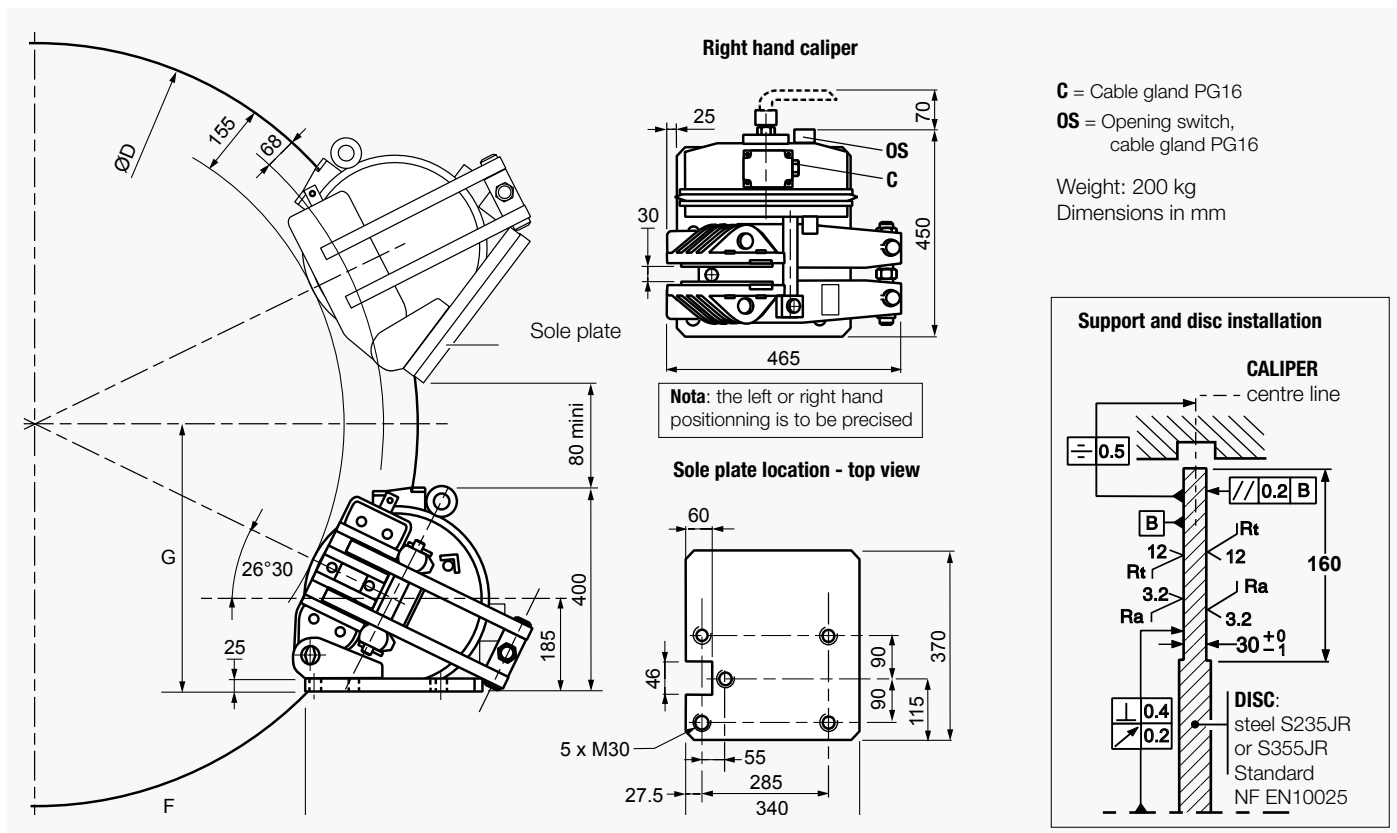

Response time at nominal torque :  
see the leaflet of the associated electrical power supply.  
Force values are subject to a variation of ±10%.

Designation	Caliper		OSA
	Lining *		US2-1
Braking force BF	Static	N	27 900
	Dynamic	N	31 000
Linear speed of the disc		m/s	≤ 10
Dynamic braking torque BT (N.m) for 1 caliper and disc ØD (mm)	1000 mm	N.m	13 400
	1200 mm	N.m	16 500
	1500 mm	N.m	21 100
	2000 mm	N.m	28 900
BT for other ØD (mm)		N.m	BT = BF (D/2000 - 0.068)
F		mm	F = (0.4475 × ØD) - 150
G		mm	G = 196 + (0.2231 × ØD)

**Opening proving switch :**

250VAC maxi., 5A maxi., with interrupting capacity : 50VA maxi  
220VDC maxi., 5A maxi., with interrupting capacity : 50W maxi  
Compatible with PLC (Programmable Logic Controllers).  
An opening switch used with other equipment than PLC must not be reused with a PLC.

- \* **US2-1:** disc temperature during one braking ≤ 150°C
- US5-:** disc temperature during one braking ≤ 350°C.  
optional. consult us.





### DISC BRAKE - 2SA CALIPER

Revision number: T03781-01-D

Revision date: 22.03.2016

Fail safe braking  
Braking by spring application  
Electromagnetic release  
Manual lining wear compensation  
Opening proving switch  
Air gap switch

**Operating conditions:**

- Ambient temperature: -10°C to +60°C
- Relative humidity ≤ 70%
- Dust in atmosphere ≥ 65µ

Other conditions, consult us.

**Use:**

The brake should be applied only in case of emergency stop, overspeed or shutdown of electric mains.

**Options:**

- Detection of full lining wear
- Load regulated lowering

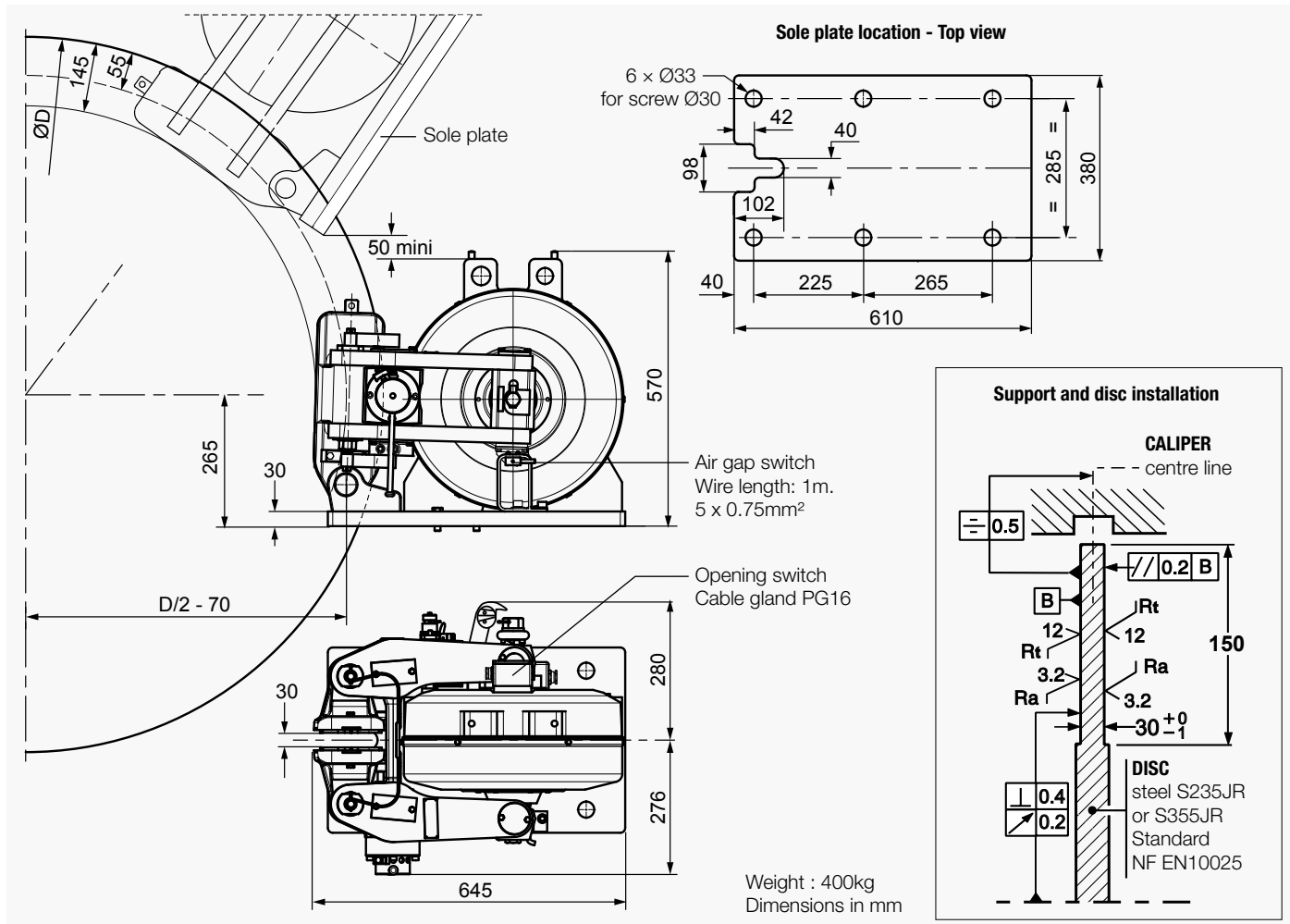

Torque and force values are subject to a variation of ±10%  
Response time at nominal torque :  
see the leaflet of the associated electrical power supply.

• **Opening proving switch:**  
250VAC maxi., 5A maxi., with interrupting capacity : 50VA maxi  
220VDC maxi., 5A maxi., with interrupting capacity : 50W maxi  
Compatible with PLC (Programmable Logic Controllers).  
An opening switch used with other equipment than PLC must not be reused with a PLC.

• **Air gap switch:**  
240V. 3A AC  
250V. 0.27A DC

Designation	Caliper	2SA	
	Lining *	US2-1	US2-5
Braking force BF for 1mm of air gap disc/lining	Static N	90 000	84 600
	Dynamic N	100 000	94 000
Linear speed of the disc	m/s	≤ 10	≤ 10
Dynamic braking torque BT for 1 caliper and disc ØD (mm)	N.m	BT = BF(D/2000 - 0.055)	

\* **US2-1:** disc temperature during one braking ≤ 150°C  
**US2-5:** disc temperature during one braking ≤ 350°C

# SIME Brakes Industrial Braking Systems

## Emergency Brakes

### APPLICATIONS

- STEEL CRANES
- PORT CRANES
- NUCLEAR CRANES

- OFFSHORE APPLICATIONS
- BOATLIFTS
- MINES AND CONVEYORS

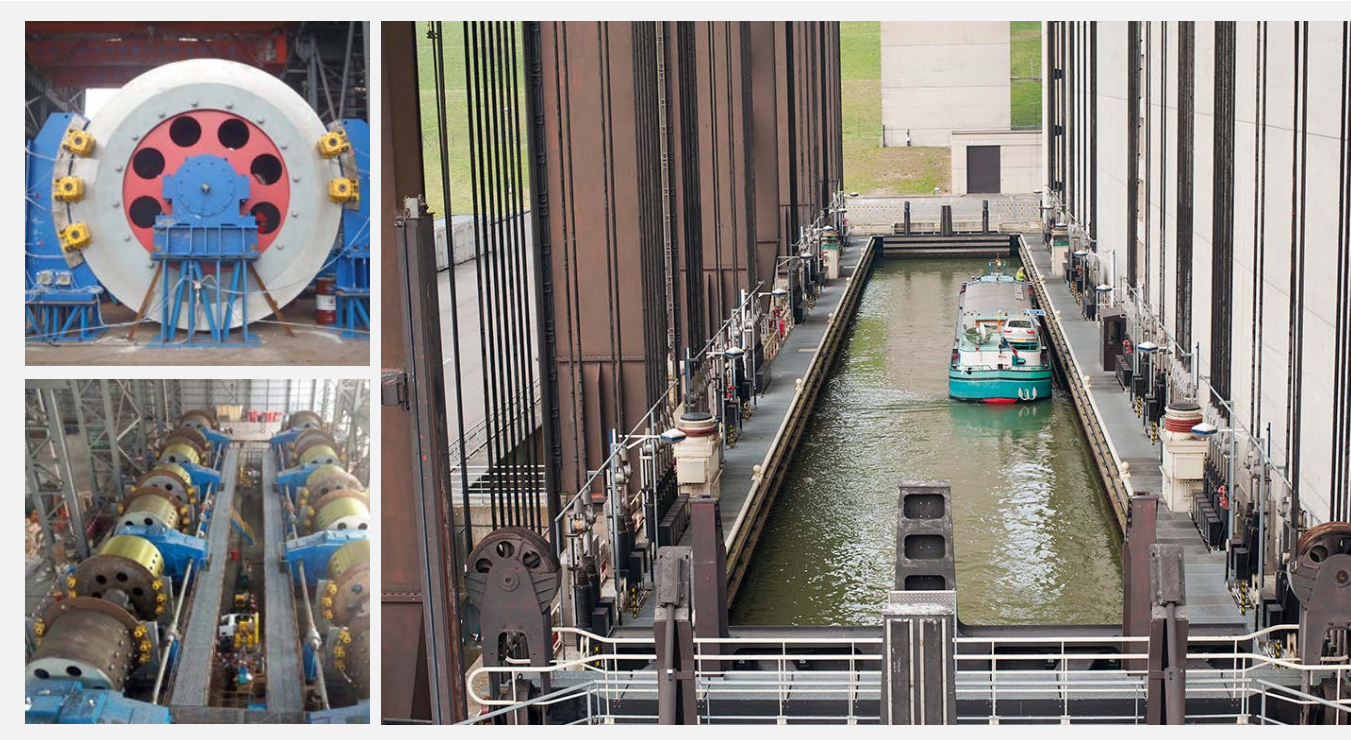

# HYDRAULIC EMERGENCY BRAKES TYPE SH

MAIN CHARACTERISTICS	OPTIONS
<ul style="list-style-type: none"> <li>• FAILSAFE BRAKE BY SPRING APPLICATION</li> <li>• HYDRAULIC RELEASE</li> <li>• OPENING PROVING SWITCH</li> <li>• LINING WEAR INDICATORS</li> </ul>	<ul style="list-style-type: none"> <li>• LINING WEAR PROVING SWITCH</li> <li>• PROGRESSIVE BRAKING SYSTEM</li> <li>• OFFSHORE PROTECTION</li> <li>• LINING TEMPERATURE SENSOR</li> <li>• HIGH TEMPERATURE, IRON AND STEEL CONDITIONS</li> </ul>



**SH**

- Association with disc thicknesses : depending on the type of caliper : 12.7 - 15 - 20 - 30 or 42 mm.



**SHS**

- Caliper mounted on a support
- Tailor-made solutions for any installation : banana supports



**SHC**

- Caliper and Hydraulic Power Pack mounted on the same support
- Option: Electrical unit

Braking torque (kN.m)

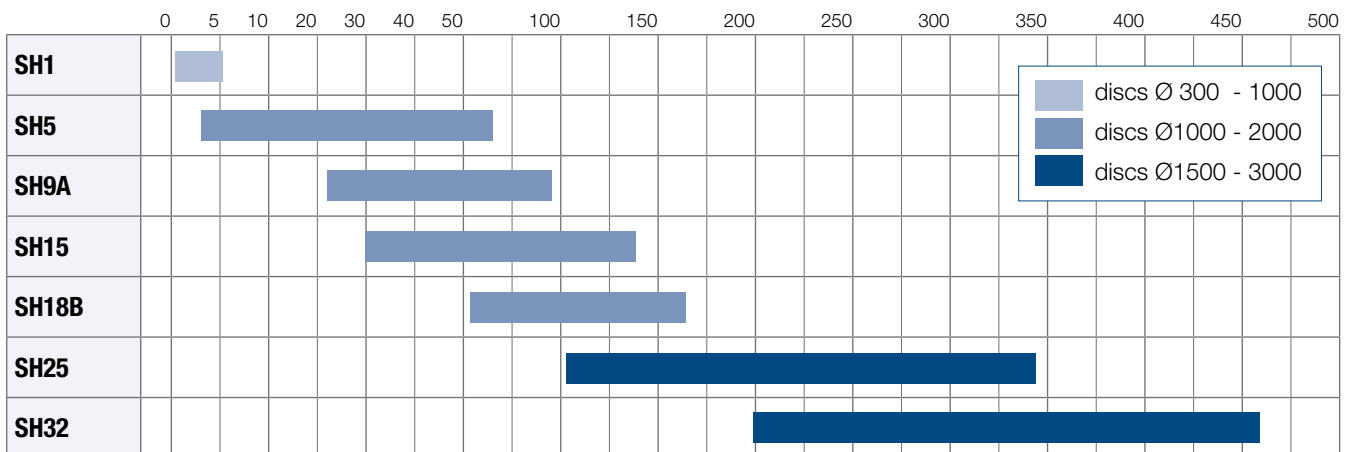

# SIME Brakes Industrial Braking Systems

## Emergency Brakes

### DISC BRAKE - SH1 CALIPER

Revision number: T10097-01-H

Revision date: 07.06.2019

Emergency brake

Fail to safe

Spring application

Hydraulic release

Linings with wear indicators

Holding tool for maintenance operation

Manual wear centering and compensation

Association with discs thickness:

12.7 (1/2"), 15, 20 and 30mm.

Lining pads type **US2-1** or **ES3-7**

Lining pads with full wear indicators

Protection C5-M M

#### Operating conditions:

- Ambient temperature:
  - Dynamic braking : -30°C to +70°C
  - Brake applied (parking): -40°C to +70°C
- Relative humidity:  $\leq 70\%$
- Dust in atmosphere  $\geq 65\mu\text{m}$
- Other conditions: consult us.

#### Use:

- The brake should be applied only in case of emergency stop, overspeed or shutdown of electric mains.
- Other use, consult us.

#### Options:

- Opening proving switch (**OS**)
- Lining wear proving switch (**WS**)
- All non-standard disc thickness  $> 12.7\text{mm}$  (1/2")
- Lining temperature sensor (**T**)
- Mechanical release tool (**DM**)
- SH1L** : caliper requiring no manual wear compensation:
  - braking force before lining wear = +10% maxi.
  - braking force after lining wear = -10% maxi.

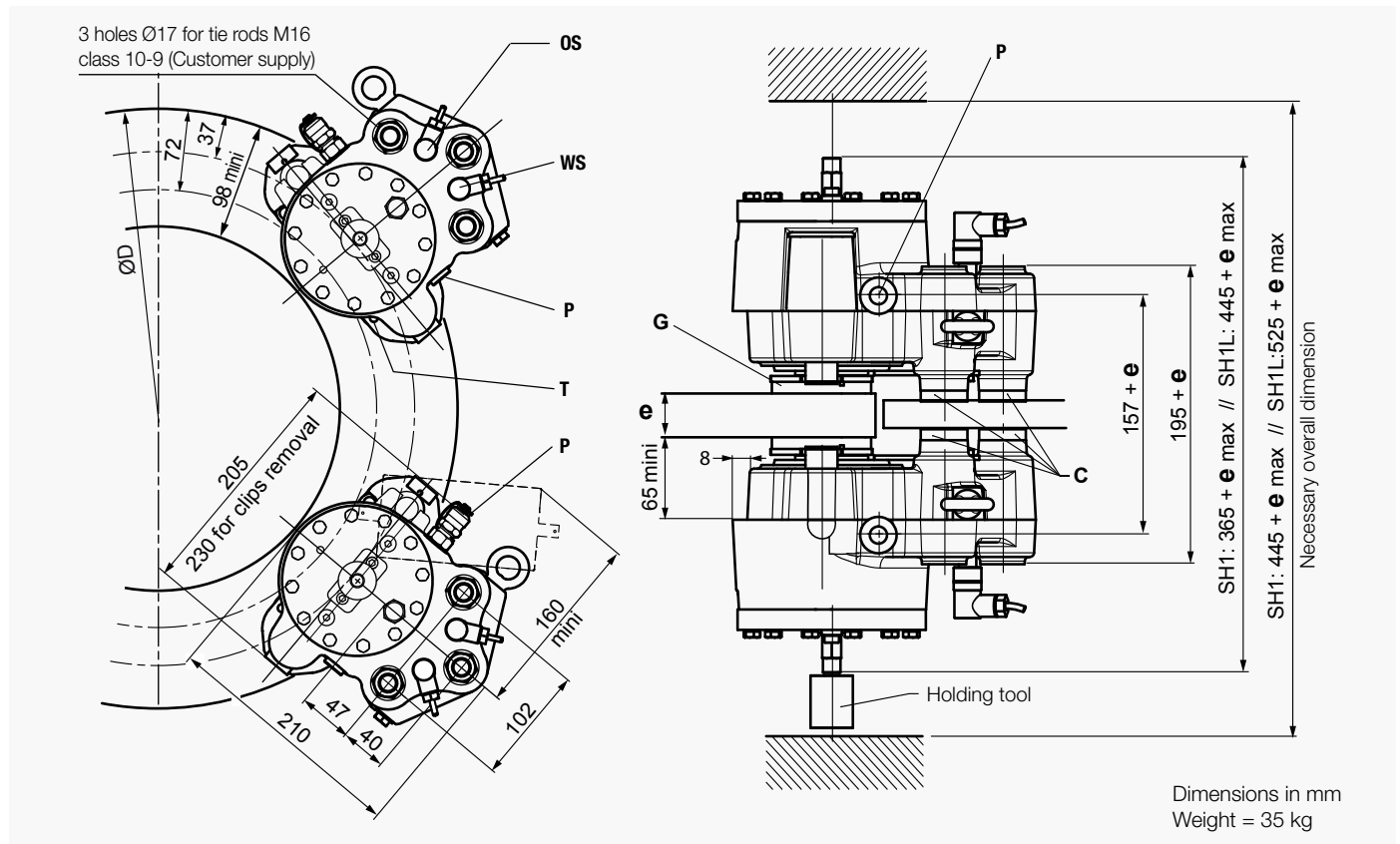

#### Electrical data:

##### Inductive switches of opening and wear (options):

- 3 wires PNP NO
- 12 to 24 VDC 200mA
- with male connector M12 / 5 positions
- according to standard IEC61076-2-101 / code A

##### Sensor PT100 (option)

- Detection of the temperature threshold :  $100^\circ\text{C} \pm 5$
- Cable length = 2.5 meters
- 2 wires red/yellow

R	136.6 $\Omega$	95°C
	138.5 $\Omega$	100°C
	140.4 $\Omega$	105°C

**C** = Spacers according to disc thickness

**G** = Linings : Thickness of new lining 8 mm  
Thickness to wear 6 mm

Each 1mm of wear on each side: manual centering and compensation

**OS** = Opening switch (option)

**WS** = Lining wear switch (option)

**P** = 2 oil ports 1/4"G per half-caliper

Bleeder screws delivered separately

**T** = PT100 sensors (option)

**ØD** = Disc diameter = 300 mm minimum

**e** = Disc thickness



### DISC BRAKE - SH1 CALIPER

Revision number: T10097-01-H

Revision date: 07.06.2019

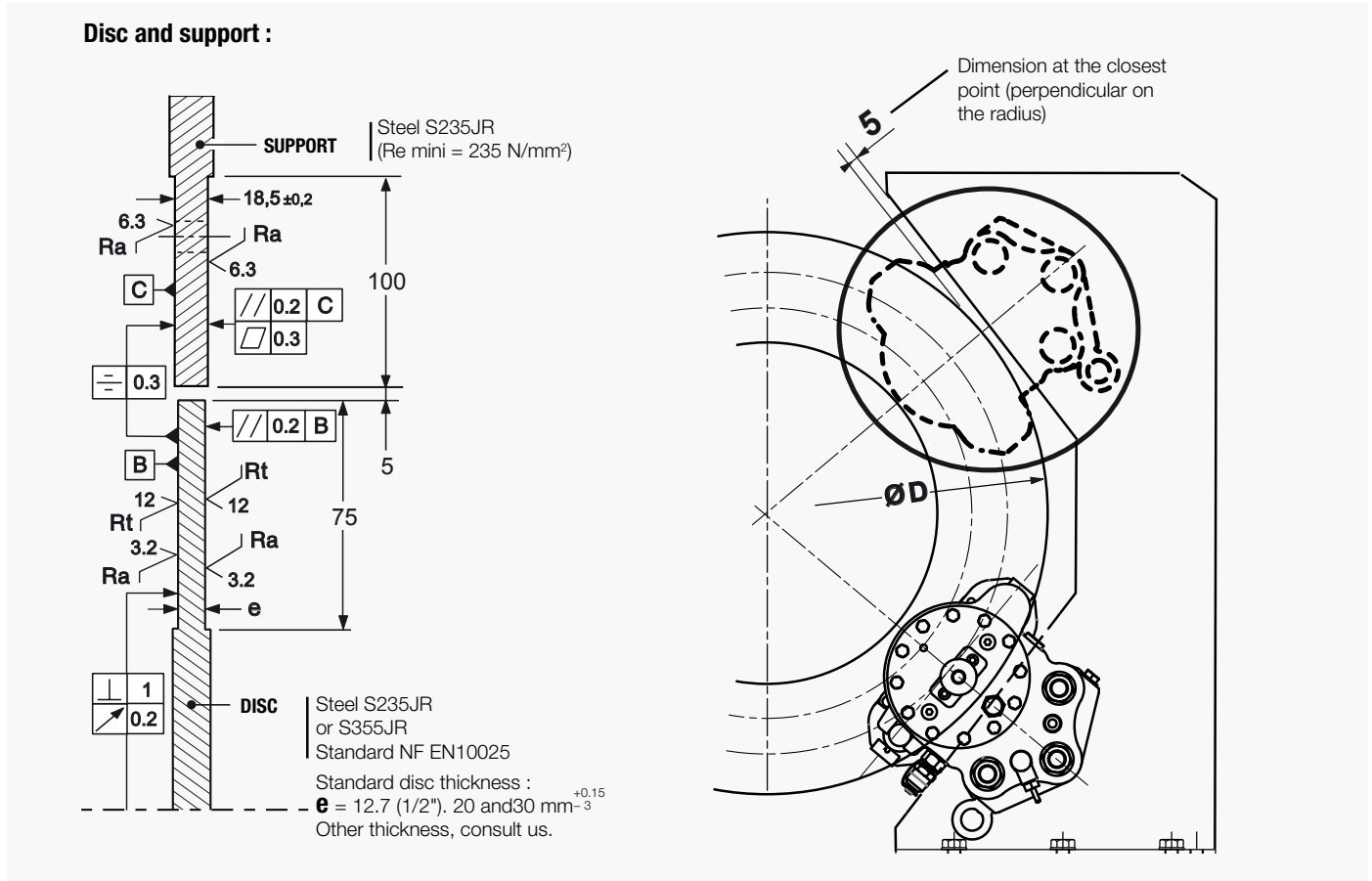

Torque and effort values are subject to a variation of ±10% - Closing time at nominal torque ≤ 0.3s

Designation	Caliper SH1-		5	4	3	2	1	5	4	3	2	1
	Lining *		US2-1					ES3-7				
Braking force BF for air gap disc/lining of 2x1mm	Dynamic	N	11 000	8 000	6 000	4 000	3 000	11 000	8 000	6 000	4 000	2 000
	Static	N	9 680	7 040	5 280	3 520	2 640	9 900	7 200	5 400	3 600	1 800
Linear speed of the disc ●		m/s	≤ 10					≤ 50				
Dynamic braking torque BT (m.N) for 1 caliper and disc ØD (mm) / 300 ≤ D ≤ 1000 mm		N.m	BT = BF (D/2000-0.037)									
Regulation pressure	Minimum	bar						150				
	Maximum	bar						170				
Setting pressure limit valve of hydraulic unit		bar						190				
Total volume of oil displaced for air gap disc/lining of:	2 x 1mm (nominal opening)	cm <sup>3</sup>						5 cm <sup>3</sup>				
	2 x 3mm (wear+opening)	cm <sup>3</sup>						13 cm <sup>3</sup>				
	2 x 7mm SH1L (wear+open.)	cm <sup>3</sup>						29 cm <sup>3</sup>				

\* ES3-7: disc temperature during one braking ≤ 600°C

US2-1: disc temperature during one braking ≤ 100°C

● For higher speed, consult us.

# SIME Brakes Industrial Braking Systems

## Emergency Brakes

### DISC BRAKE - SHS1 AND SHC1 CALIPERS

Revision number: T10099-01-F

Revision date: 10.06.2016

Emergency brake

Fail to safe

Spring application

Hydraulic release

Holding tool for maintenance operation

Manual wear centering and compensation

Possible association possible with discs thickness:

12.7 to 30 mm.

Lining pads type **US2-1** or **ES3-7**

Lining pads with full wear indicators

Protection : Caliper **SHS1** : C5-M M

HPP **CE1L** : C4 M

#### Operating conditions:

- Ambient temperature:

Caliper **SHS1**:

Dynamic braking : -30°C to +70°C

Brake applied (parking): -40°C to +70°C

HPP **CE1L** : -20°C to +70°C

- Relative humidity:  $\leq 70\%$
  - Dust in atmosphere  $\geq 65\mu\text{m}$
- Other conditions: consult us.

#### Use:

- The brake should be applied only in case of emergency stop, overspeed or shutdown of electric mains.
- Other use, consult us.

#### Options:

- Opening proving switch (**OS**)
- Lining wear proving switch (**WS**)
- Lining temperature sensor (**T**)
- SHS1L - SHC1L** : caliper with no need of manual wear compensation:
  - braking force before lining wear = +10% maxi.
  - braking force after lining wear = -10% maxi.
- CE1L** HPP options : see "Installation and maintenance" leaflet quoted below.

**SHS1** = **SH1** caliper with integral support

**SHC1** = **SH1** caliper with integral **CE1L** hydraulic power pack.

#### L = Linings :

Thickness of new lining 8 mm

Thickness to wear 6 mm

Each 1 mm of wear on each side: manual centering and compensation

**OS** = Opening proving switch (option)

**WS** = Wear proving switch (option)

**P** = Oil ports 1/4"G

Bleeder screws delivered separately

**T** = PT100 sensors (option)

**ØD** : from 300 to 1000 mm

**e** = disc thickness

Dimensions in mm

Weight : **SHC1** = 61 kg **SHC1L** = 68 kg

**SHS1** = 39 kg **SHS1L** = 46 kg

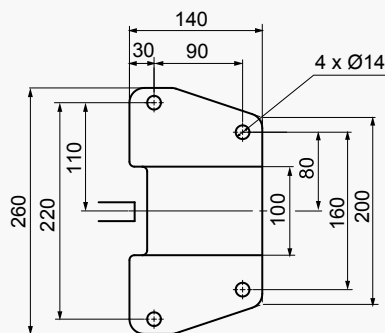
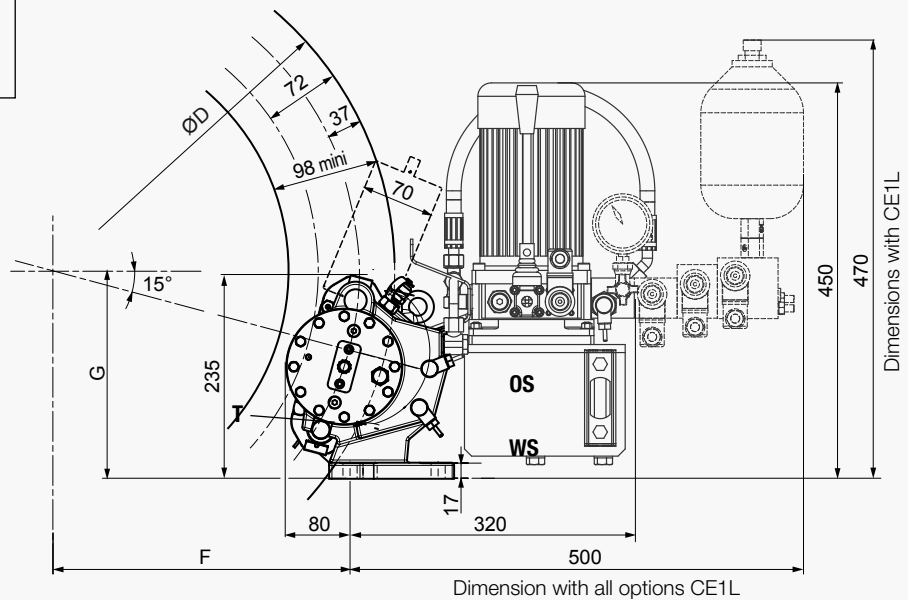

Calipers fastening :  
4 bolts M12 class 10-9 (not provided)  
Tightening torque = 77 Nm  $\pm$  30%

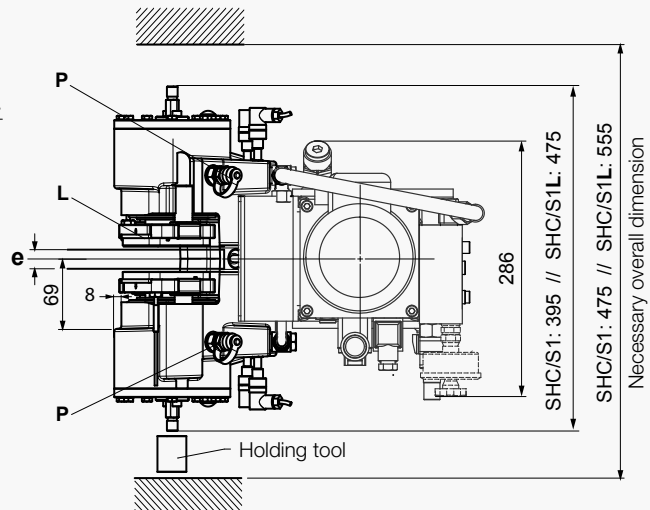

### DISC BRAKE - SHS1 AND SHC1 CALIPERS

Revision number: T10099-01-F

Revision date: 10.06.2016

#### Installation instructions :

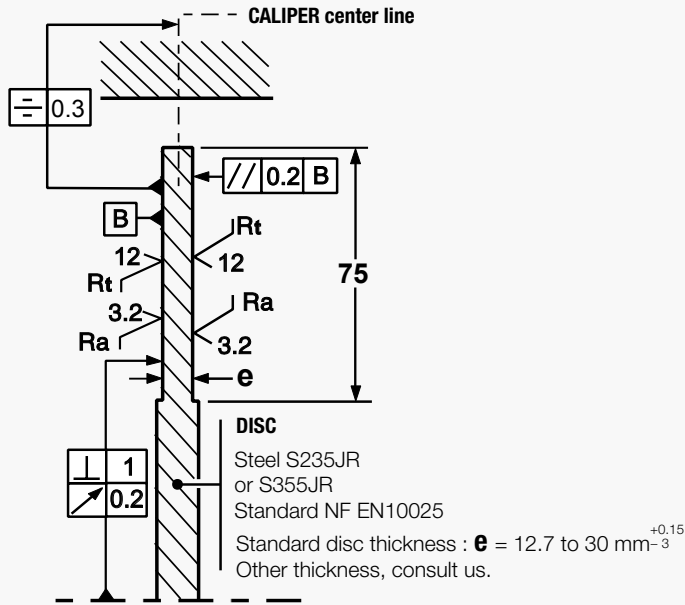

#### Electrical data:

##### Opening and wear inductive switches (options)

3 wires PNP NO  
12 to 24 VDC 200mA  
with connector M12 / 5 positions  
according to standard IEC61076-2-101 / code A

##### Sensor PT100 (option)

Detection of the temperature threshold : 100°C ± 5  
- R = 136.6 Ω at 95 °C  
- R = 138.5 Ω at 100°C  
- R = 140.4 Ω at 105°C  
Cable length = 2.5 meters  
2 wires red/yellow

Torque and effort values are subject to a variation of ±10% - Closing time at nominal torque ≤ 0.3s

Designation	Caliper SHS1- SHC1-		5	4	3	2	1	5	4	3	2	1
	Lining *		US2-1					ES3-7				
Braking force BF for air gap disc/lining of 2x1mm	Dynamic	N	11 000	8 000	6 000	4 000	3 000	11 000	8 000	6 000	4 000	2 000
	Static	N	9 680	7 040	5 280	3 520	2 640	9 900	7 200	5 400	3 600	1 800
Linear speed of the disc ●	m/s		≤ 10					≤ 50				
Dynamic braking torque BT (m.N) for 1 caliper and disc ØD (mm) 300 ≤ D ≤ 1000 mm	N.m		BT = BF (D/2000-0.037)									
Regulation pressure	Minimum	bar	150									
	Maximum	bar	170									
Setting pressure limit valve of HPP	bar		190									
F			F = (0.483 x D) - 14									
G			G = (0.129 x D) + 118									

\* ES3-7: disc temperature during one braking ≤ 600°C

US2-1: disc temperature during one braking ≤ 100°C

● For higher speed, consult us.

# SIME Brakes Industrial Braking Systems

## Emergency Brakes

### DISC BRAKE - SH5 CALIPER

Revision number: T03865-02-C

Revision date: 23.09.2010

Emergency brake  
Fail safe  
Spring application  
Hydraulic release  
Opening proving switches  
Lining wear detector

**Operating conditions :**

- Ambient temperature: -10°C to +60°C
  - Relative humidity:  $\leq 70\%$
  - Dust in atmosphere  $\geq 65\mu$
- Other conditions: consult us.

**Use :**

- The brake should be applied only in case of emergency stop, overspeed or shutdown of electric mains. Other use, consult us.

**Options :**

- Automatic lining wear compensation (WACS)
- Lining wear control switch
- Progressive braking system
- Marine protection
- Caliper on support with integral hydraulic power unit

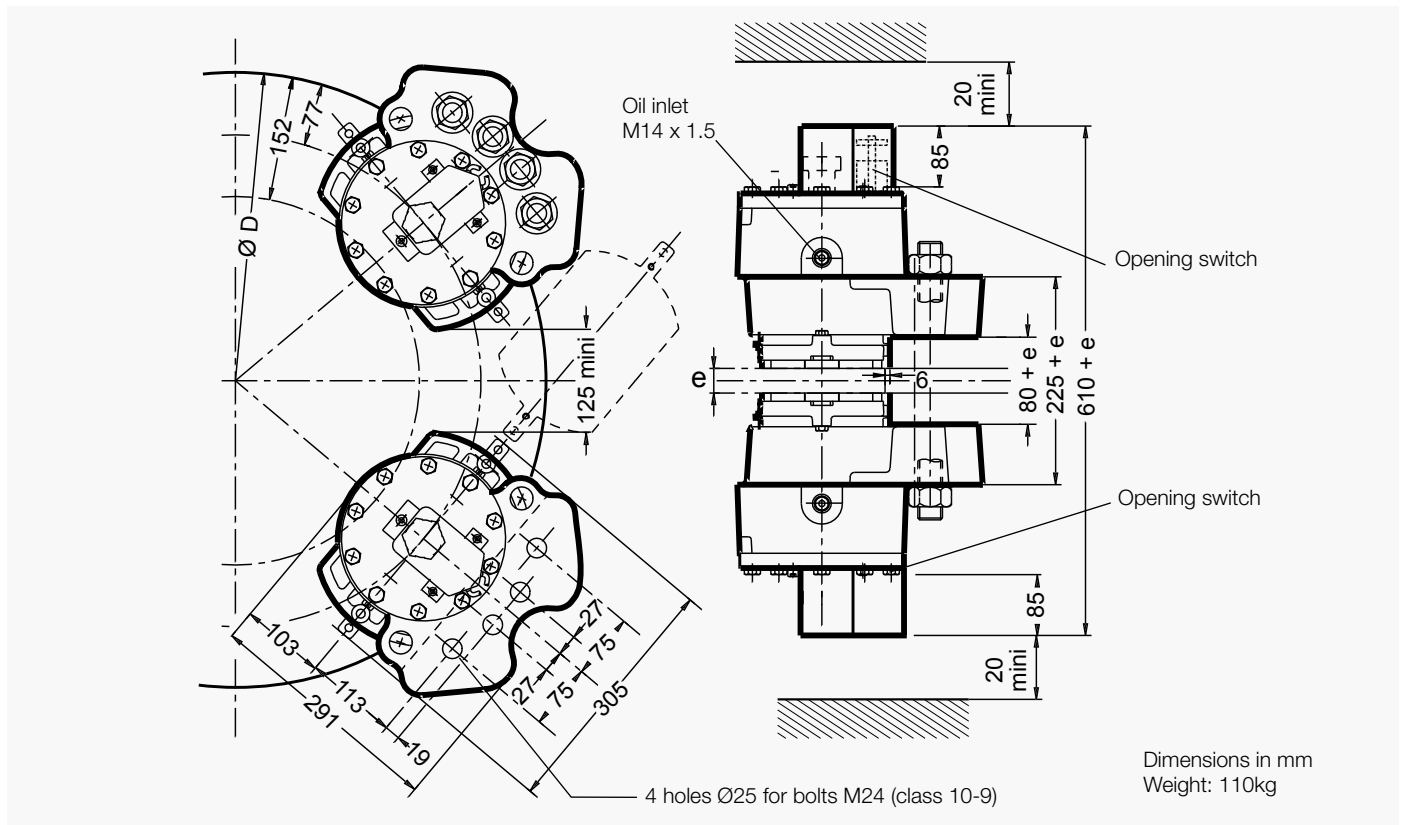

**Opening proving switch :**

250VAC maxi., 5A maxi.,  
with interrupting capacity: 50VA maxi.  
220VDC maxi., 5A maxi.,  
with interrupting capacity: 50W maxi.

Compatible with PLC  
(Programmable Logic Controllers).  
An opening switch used with other equipment than PLC must  
not be reused with a PLC.

### DISC BRAKE - SH5 CALIPER

Revision number: T03865-02-C

Revision date: 23.09.2010

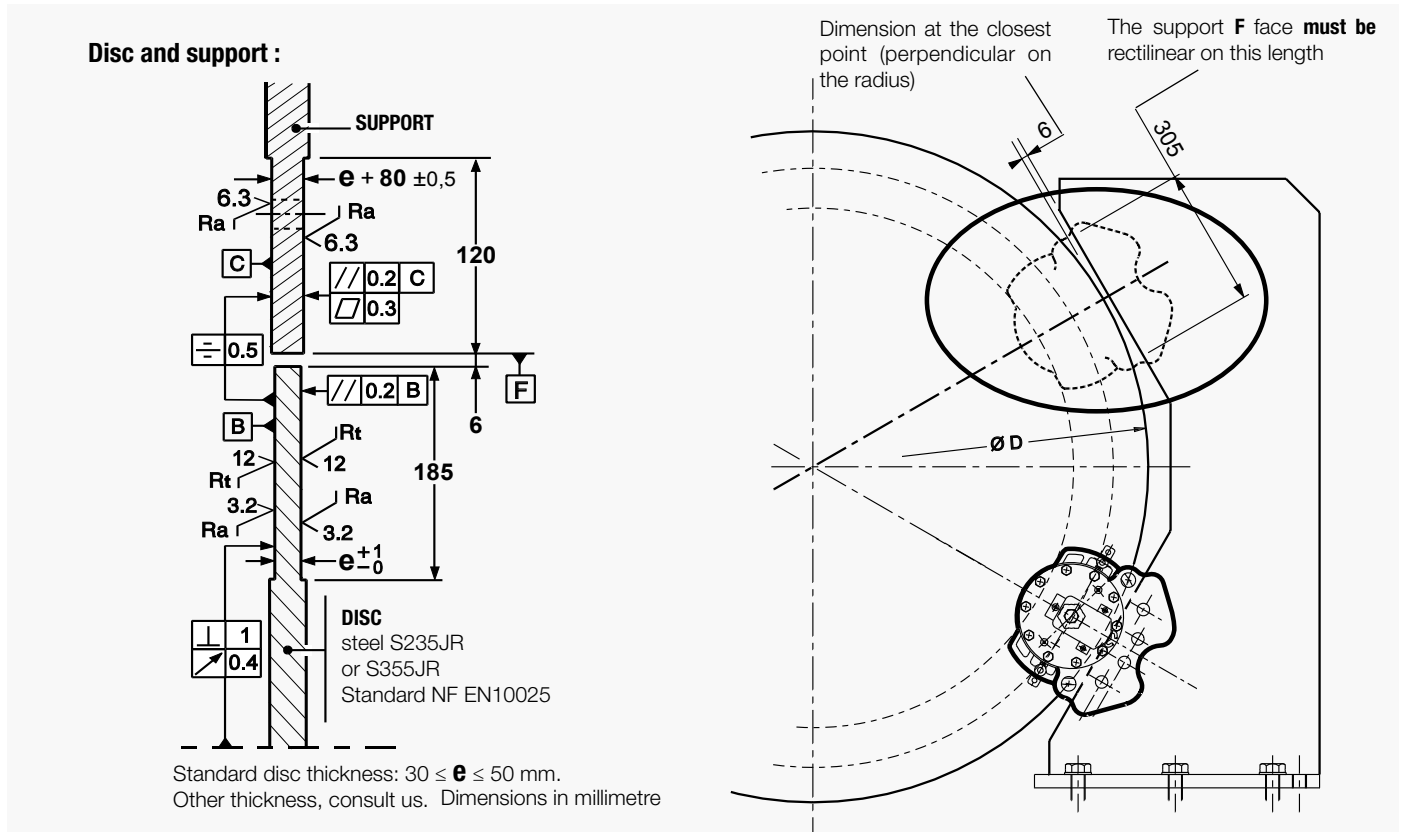

Torque and effort values are subject to a variation of  $\pm 10\%$

Response time at nominal torque : see the leaflet n° G08555-01

Designation	Caliper		SH5-6		SH5-5		SH5-4		SH5-3		SH5-2	
	Lining *		US2-1	WS1-3	US2-1	WS1-3	US2-1	WS1-3	US2-1	WS1-3	US2-1	WS1-3
Braking force BF for 1mm of air gap disc/lining	Static	N	63 000	43 200	51 300	35 100	37 800	25 900	21 200	14 500	9 600	6 500
	Dynamic	N	70 000	48 000	57 000	39 100	42 000	28 800	23 600	16 200	10 700	7 300
Linear speed of the disc		m/s	≤ 10	≤ 50	≤ 10	≤ 50	≤ 10	≤ 50	≤ 10	≤ 50	≤ 10	≤ 50
Dynamic braking torque BT (N.m) for 1 caliper and disc ØD (mm)	995 mm	N.m	29430	20 180	23 960	16 440	17 660	12 110	9 920	6 810	4 490	3 070
	1200 mm	N.m	36610	25 100	29 810	20 440	21 960	15 060	12 340	8 470	5 590	3 810
	1500 mm	N.m	47110	32 300	38 360	26 310	28 260	19 380	15 880	10 900	7 200	4 910
	2000 mm	N.m	64610	44 300	52 610	36 080	38 760	26 580	21 780	14 950	9 870	6 730
BT for other ØD (mm)		N.m	BT = BF (D/2000 - 0.077)									
Regulation pressure	minimum	bar	180		140		110		85		40	
	maximum	bar	200		160		140		115		60	
Setting pressure of the limit valve of hydraulic power unit		bar	210		190		165		140		80	
Total volume of oil displaced		cm <sup>3</sup>	35 for one stroke disc/lining (nominal wear and opening)									

\* US2-1: disc temperature during one braking  $\leq 150^\circ\text{C}$

WS1-3: disc temperature during one braking  $\leq 600^\circ\text{C}$

US2-5: disc temperature during one braking  $\leq 350^\circ\text{C}$ , optional, consult us.



### DISC BRAKE - SHC5 CALIPER

Revision number: T03867-02-D

Revision date: 26.10.2011

#### Installation instructions

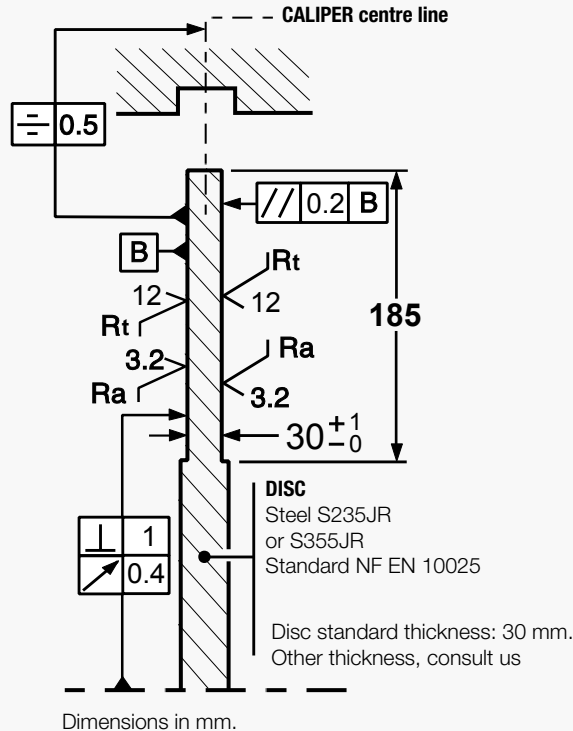

#### Electrical data

- **Motor voltages :**  
3 phases : 230/400 VAC 50 Hz  
0.37 kW. 4 poles  
for mains:  
220-230-240VAC ±10% 50Hz  
or 380-400-415VAC ±10% 50Hz
- **Options motor :**  
440 VAC 50Hz  
500 VAC 50Hz  
480 VAC 60Hz  
575 VAC 60Hz
- Other voltages. consult us.
- Electrical casing IP55
- **Opening switch :**  
250VAC maxi., 5A maxi.,  
with interrupting capacity: 50VA maxi.  
220VDC maxi., 5A maxi.,  
with interrupting capacity: 50W maxi.  
Compatible with PLC  
(Programmable Logic Controllers).  
An opening switch used with other equipment  
than PLC must not be reused with a PLC.

Torque and effort values are subject to a variation of ±10%  
Response time at nominal torque : see the leaflet n° G08555-01.

Désignation	caliper		SHC5-6		SHC5-5		SHC5-4		SHC5-3		SHC5-2	
	Lining *		US2-1	WS1-3	US2-1	WS1-3	US2-1	WS1-3	US2-1	WS1-3	US2-1	WS1-3
Braking force BF for 1mm of air gap disc/lining	Static	N	63 000	43 200	51 300	35 100	37 800	25 900	21 200	14 500	9 600	6 500
	Dynamic	N	70 000	48 000	57 000	39 100	42 000	28 800	23 600	16 200	10 700	7 300
Linear speed of the disc		m/s	≤ 10	≤ 50	≤ 10	≤ 50	≤ 10	≤ 50	≤ 10	≤ 50	≤ 10	≤ 50
Dynamic braking torque BT (N.m) for 1 caliper and disc ØD (mm)	995 mm	N.m	29430	20 180	23 960	16 440	17 660	12 110	9 920	6 810	4 490	3 070
	1200 mm	N.m	36610	25 100	29 810	20 440	21 960	15 060	12 340	8 470	5 590	3 810
	1500 mm	N.m	47110	32 300	38 360	26 310	28 260	19 380	15 880	10 900	7 200	4 910
	2000 mm	N.m	64610	44 300	52 610	36 080	38 760	26 580	21 780	14 950	9 870	6 730
BT for other ØD (mm)		N.m	BT = BF (D/2000 - 0.077)									
Setting pressure of the limit valve of hydraulic power unit		bar	210		190		165		140		80	
F		mm	F = (0.4719 x D) - 122.5									
G		mm	G = (0.1652 x D) + 232.5									
L		mm	L = (D / 2) - 181									

- \* **US2-1:** disc temperature during one braking ≤ 150°C
- WS1-3:** disc temperature during one braking ≤ 600°C
- US2-5:** disc temperature during one braking ≤ 350°C, optional, consult us.

# SIME Brakes Industrial Braking Systems

## Emergency Brakes

### DISC BRAKE - SH9A CALIPER

Revision number: T10077-01-B

Revision date: 30.05.2013

Emergency brake  
Fail safe  
Spring application  
Hydraulic release  
Opening proving switches.

#### Operating conditions:

- Ambient temperature:  $-10^{\circ}\text{C}$  to  $+60^{\circ}\text{C}$
- Relative humidity:  $\leq 70\%$
- Dust in atmosphere  $\geq 65\mu$
- Other conditions: consult us.

#### Use:

- The brake should be applied only in case of emergency stop, overspeed or shutdown of electric mains. Other use, consult us.

- US2-1. US2-5 for low energy braking  $\leq 1$  MJ
- EF3-1 for high energy braking  $\leq 15$  MJ
- Other use, consult us

#### Options:

- Lining wear control switch
- Switch for P.L.C. (induction sensor)
- Marine protection
- Caliper on support with integral HPP
- Option GF

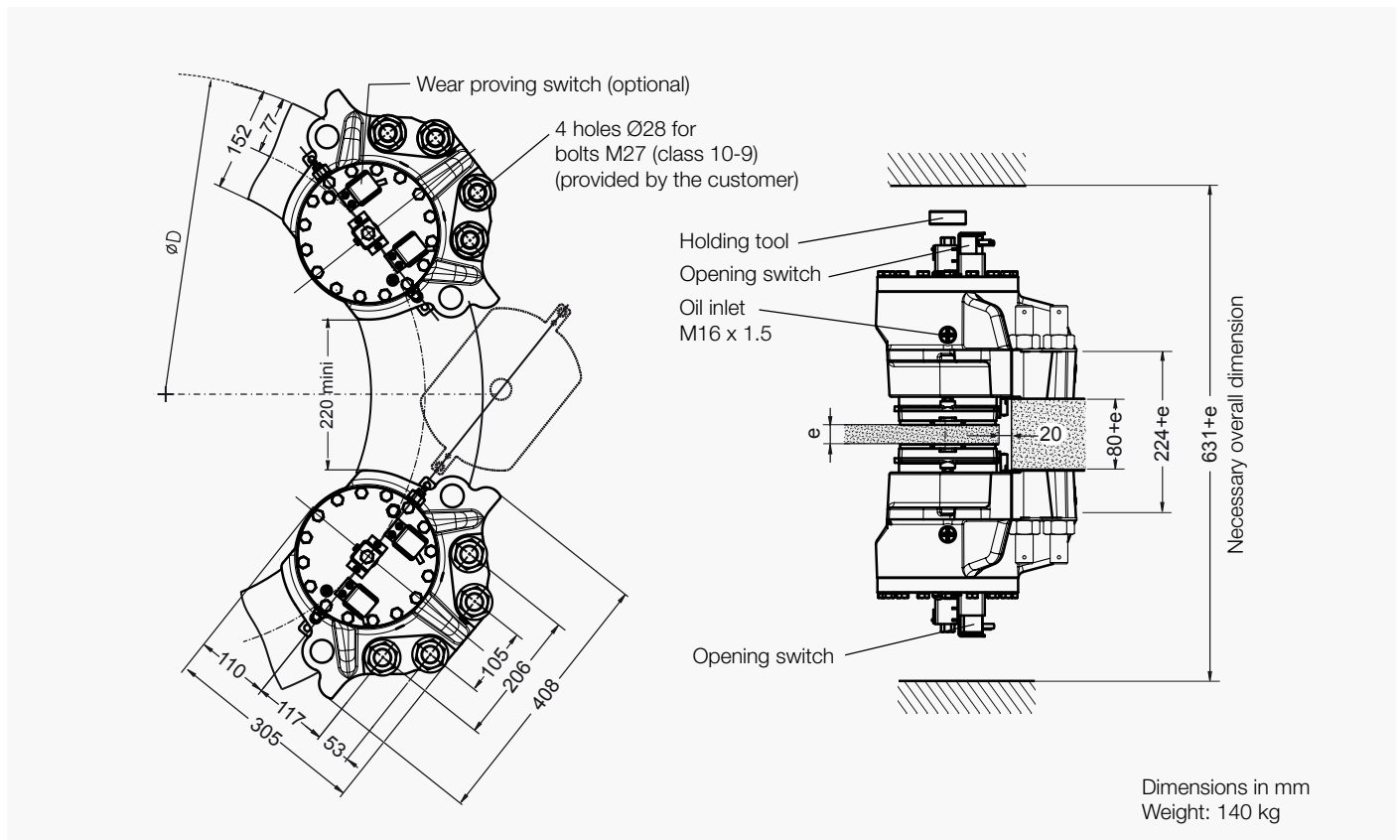

#### Opening proving switch:

240V 1.5A AC  
250V 0.1A DC  
with a  $5 \times 0.75\text{mm}^2$  wire  
of 5m length



### DISC BRAKE - SH9A CALIPER

Revision number: T10077-01-B

Revision date: 30.05.2013

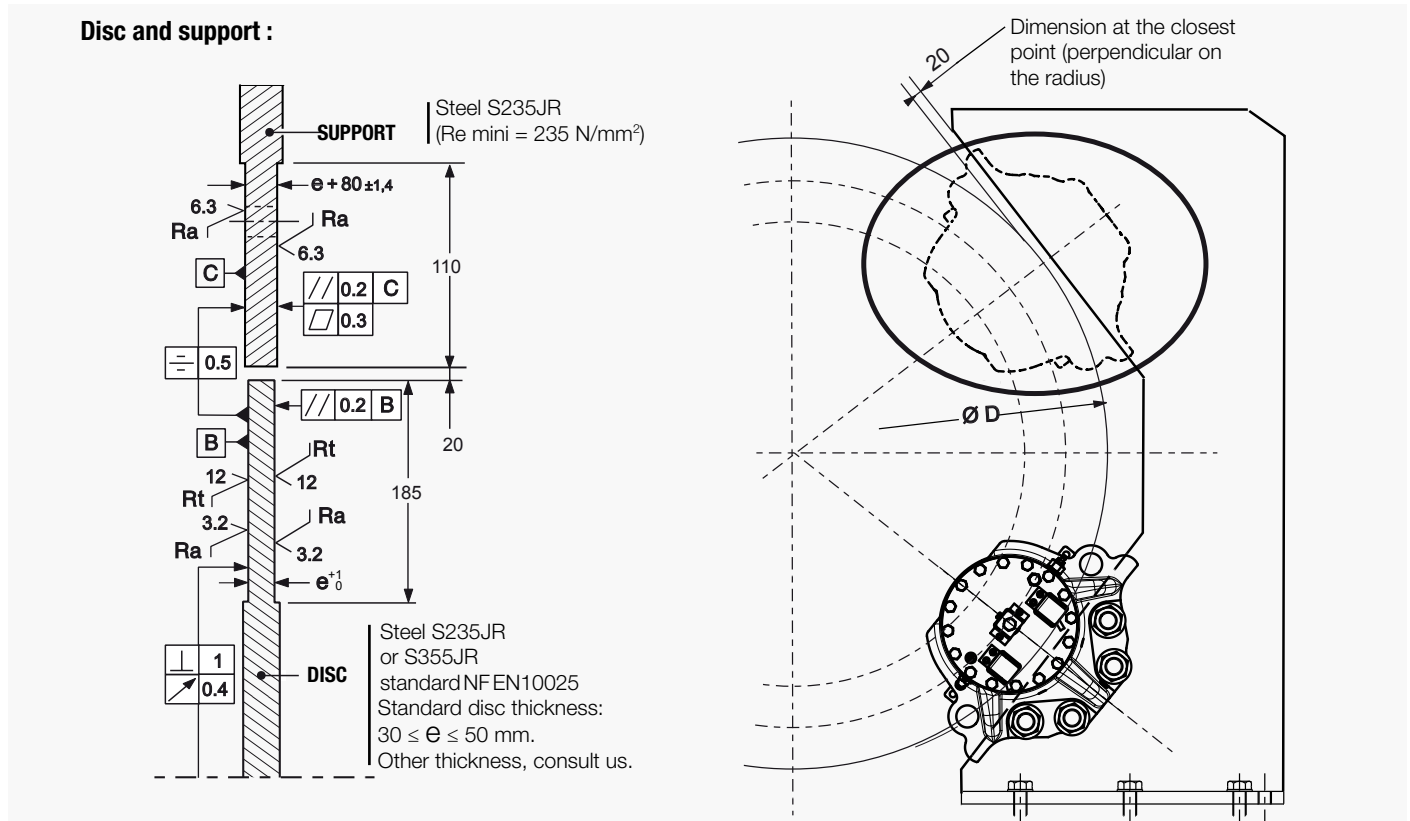

Torque and effort values are subject to a variation of ±10%  
Response time at nominal torque ≤ 0.3s

Designation	Caliper		SH9A-3			SH9A-2			SH9A-1		
	Lining *		US2-1	US2-5	EF3-1	US2-1	US2-5	EF3-1	US2-1	US2-5	EF3-1
Braking force BF for 1mm air gap	Static	N	94 500	90 000	70 500	80 100	76 200	60000	66 150	63 000	49 600
	Dynamic	N	105 000	100 000	78 200	89 000	84 700	66 500	73 500	70 000	55 000
Linear speed of the disc for BF		m/s	≤10	≤30	≤ 50●	≤10	≤30	≤ 50●	≤10	≤30	≤ 50●
Dynamic braking torque BT (N.m) for 1 caliper and disc ØD (mm) **	995 mm	N.m	44 150	42 050	32 880	37 420	35 620	27 960	30 910	29 440	23 130
	1500 mm	N.m	70 670	67 300	52 630	59 900	57 000	44 750	49 470	47 110	37 020
	2000 mm	N.m	96 920	92 300	72 180	82 150	78 180	61 380	67 840	64 610	50 770
BT for other ØD (mm)		N.m	BT = BF (D/2000 - 0.077)								
Regulation pressure	Minimum	bar	180			150			110		
	Maximum	bar	200			180			140		
Setting pressure of HPP limit valve		bar	225			210			165		
Total volume of oil displaced		cm <sup>3</sup>	55 for one disc/linings stroke (nominal wear and opening)								

\* **US2-1:** disc temperature during one braking ≤ 150°C  
**US2-5:** disc temperature during one braking ≤ 350°C  
**EF3-1:** High energy braking, disc temperature during one braking ≤ 600°C

\*\* For disc ØD < 995 mm, consult us.

● For higher speed, consult us.

# SIME Brakes Industrial Braking Systems

## Emergency Brakes

### DISC BRAKE - SHC9A CALIPER

Revision number: T10078-01-B

Revision date: 13.06.2014

Emergency brake  
Fail to safe  
Spring application  
Hydraulic release  
Integral hydraulic power unit  
Self contained electrical system  
Opening proving switches  
Protection class C3L standard ISO12944-2

**Operating conditions:**

- Ambient temperature: -10°C to +60°C
- Relative humidity: ≤ 70%
- Dust in atmosphere ≥ 65µ

Other conditions: consult us.

**Options:**

- Lining wear control switch
- Switch for P.L.C.
- Protection class C4M standard ISO12944-2

**Use:**

- The brake should be applied only in case of emergency stop, overspeed or shutdown of electric mains.
- US2-1. US2-5 for low energy braking ≤ 1 MJ
- EF3-1 for high energy braking ≤ 15 MJ

Other use, consult us

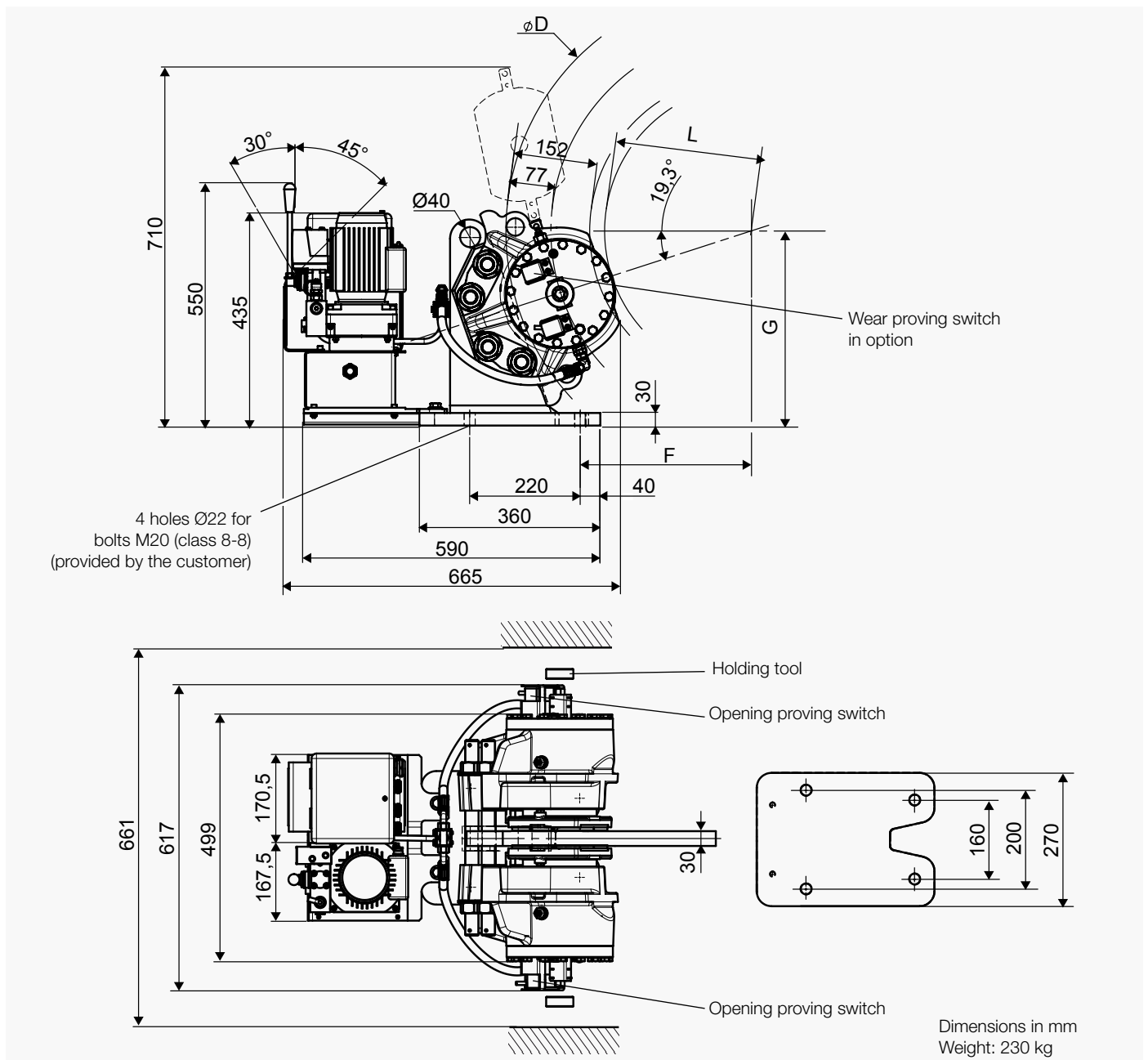

### DISC BRAKE - SHC9A CALIPER

Revision number: T10078-01-B

Revision date: 13.06.2014

#### Installation instructions

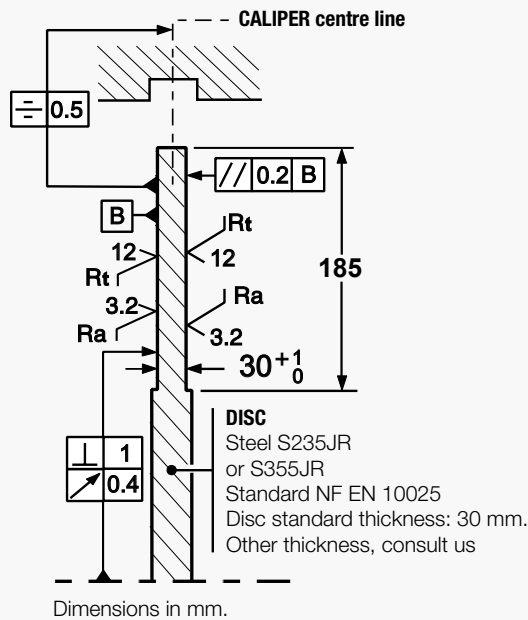

#### Electrical data

- Motor voltages:  
3 phases:  
230/400 V  $\pm 10\%$  50 Hz  
0.37 kW  
for voltage of 3 phases mains:  
230 V 50 Hz  
or 400 V 50 Hz  
or 415 V 50 Hz  
or 440 V 60 Hz  
or 460 V 60 Hz
- Options voltage of 3 phases mains:  
440 V  $\pm 10\%$  50Hz  
500 V  $\pm 10\%$  50Hz  
480 V  $\pm 10\%$  60Hz
- Other voltages, consult us.
- Electrical casing IP55
- Opening switch:  
240V. 1.5A AC  
220V. 0.1A DC  
with cable 5 x 0.75mm<sup>2</sup> length 5m

Torque and effort values are subject to a variation of  $\pm 10\%$   
Closing time at nominal torque  $\leq 0.3s$

Designation	Caliper		SHC9A-3			SHC9A-2			SHC9A-1		
	Lining *		US2-1	US2-5	EF3-1	US2-1	US2-5	EF3-1	US2-1	US2-5	EF3-1
Braking force BF for 1mm air gap	Static	N	94 500	90 000	70 500	80 100	76 200	60 000	66 150	63 000	49 600
	Dynamic	N	105 000	100 000	78 200	89 000	84 700	66 500	73 500	70 000	55 000
Linear speed of the disc for BF		m/s	$\leq 10$	$\leq 30$	$\leq 50$ ●	$\leq 10$	$\leq 30$	$\leq 50$ ●	$\leq 10$	$\leq 30$	$\leq 50$ ●
Dynamic braking torque BT (N.m) for 1 caliper and disc ØD (mm) **	995 mm	N.m	44 150	42 050	32 880	37 420	35 620	27 960	30 910	29 440	23 130
	1500 mm	N.m	70 670	67 300	52 630	59 900	57 000	44 750	49 470	47 110	37 020
	2000 mm	N.m	96 920	92 300	72 180	82 150	78 180	61 380	67 840	64 610	50 770
BT for other ØD (mm)		N.m	BT = BF (D/2000 - 0.077)								
Regulation pressure	Minimum	bar	180			150			110		
	Maximum	bar	200			180			140		
Setting pressure of limit valve of hydraulic power unit		bar	225			210			165		
F		mm	F = (0.4719 x D) - 113								
G		mm	G = (0.1652 x D) + 236.7								
L		mm	L = (D / 2) - 190								

- \* **US2-1:** disc temperature during one braking  $\leq 150^\circ\text{C}$
- US2-5:** disc temperature during one braking  $\leq 350^\circ\text{C}$
- EF3-1:** High energy braking, disc temperature during one braking  $\leq 600^\circ\text{C}$

\*\* For disc ØD < 995 mm, consult us

● For higher speed, consult us.

# SIME Brakes Industrial Braking Systems

## Emergency Brakes

### DISC BRAKE - SH15 CALIPER

Revision number: T03905-01-B

Revision date: 01.10.2010

Emergency brake  
Fail safe  
Spring application  
Hydraulic release  
Opening proving switches  
Lining wear detector

**Operating conditions:**

- Ambient temperature: -10°C to +60°C
  - Relative humidity: ≤ 70%
  - Dust in atmosphere ≥ 65µ
- Other conditions: consult us.

**Use:**

- The brake should be applied only in case of emergency stop, overspeed or shutdown of electric mains, Other use. consult us.

**Options:**

- Lining wear control switch
- Progressive braking system
- Marine protection
- Caliper on support with integral hydraulic power pack

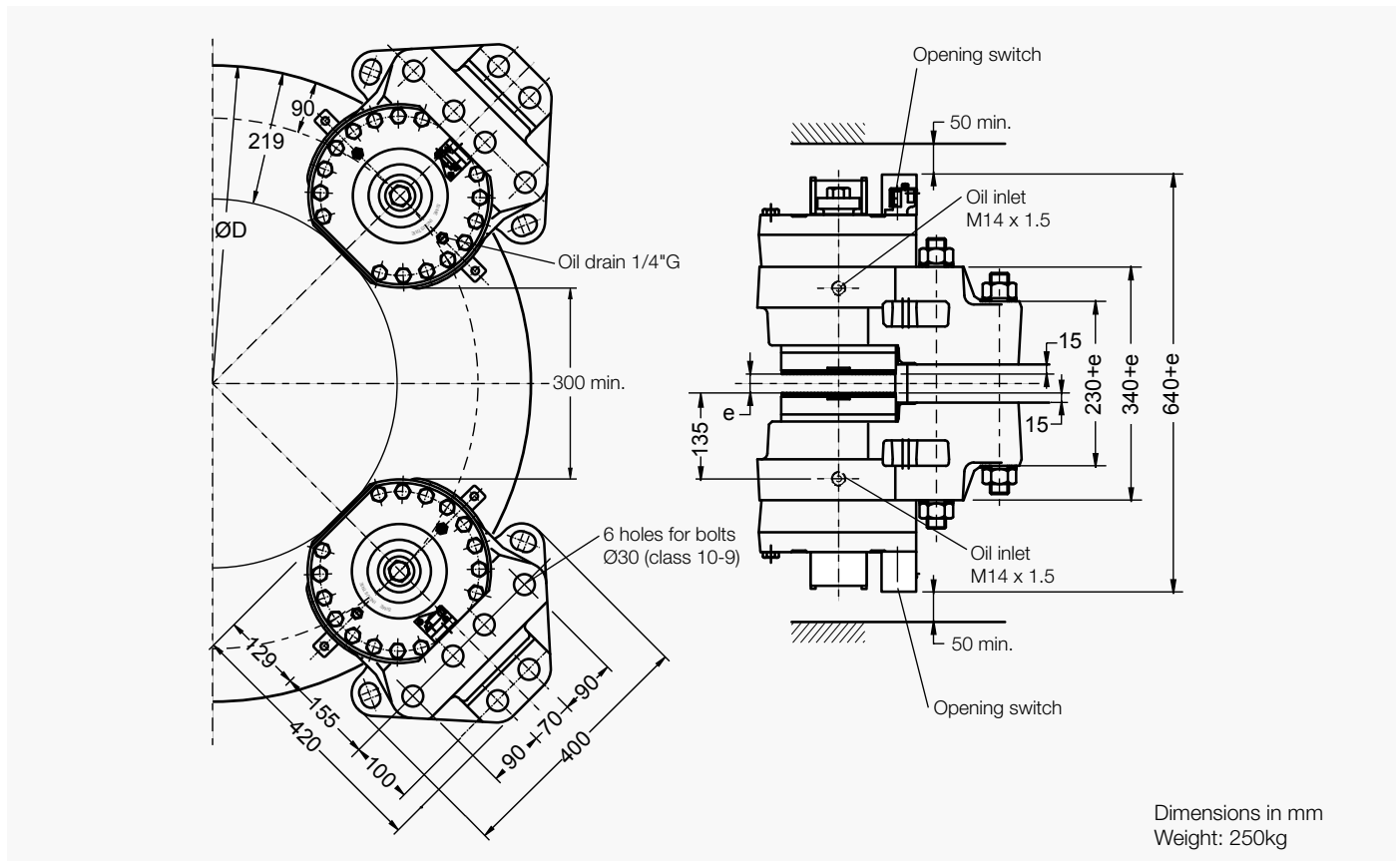

**Opening proving switch :**

250VAC maxi., 5A maxi.,  
with interrupting capacity: 50VA maxi.  
220VDC maxi., 5A maxi.,  
with interrupting capacity: 50W maxi.

Compatible with PLC  
(Programmable Logic Controllers).  
An opening switch used with other equipment than PLC must  
not be reused with a PLC.

### DISC BRAKE - SH15 CALIPER

Revision number: T03905-01-B

Revision date: 01.10.2010

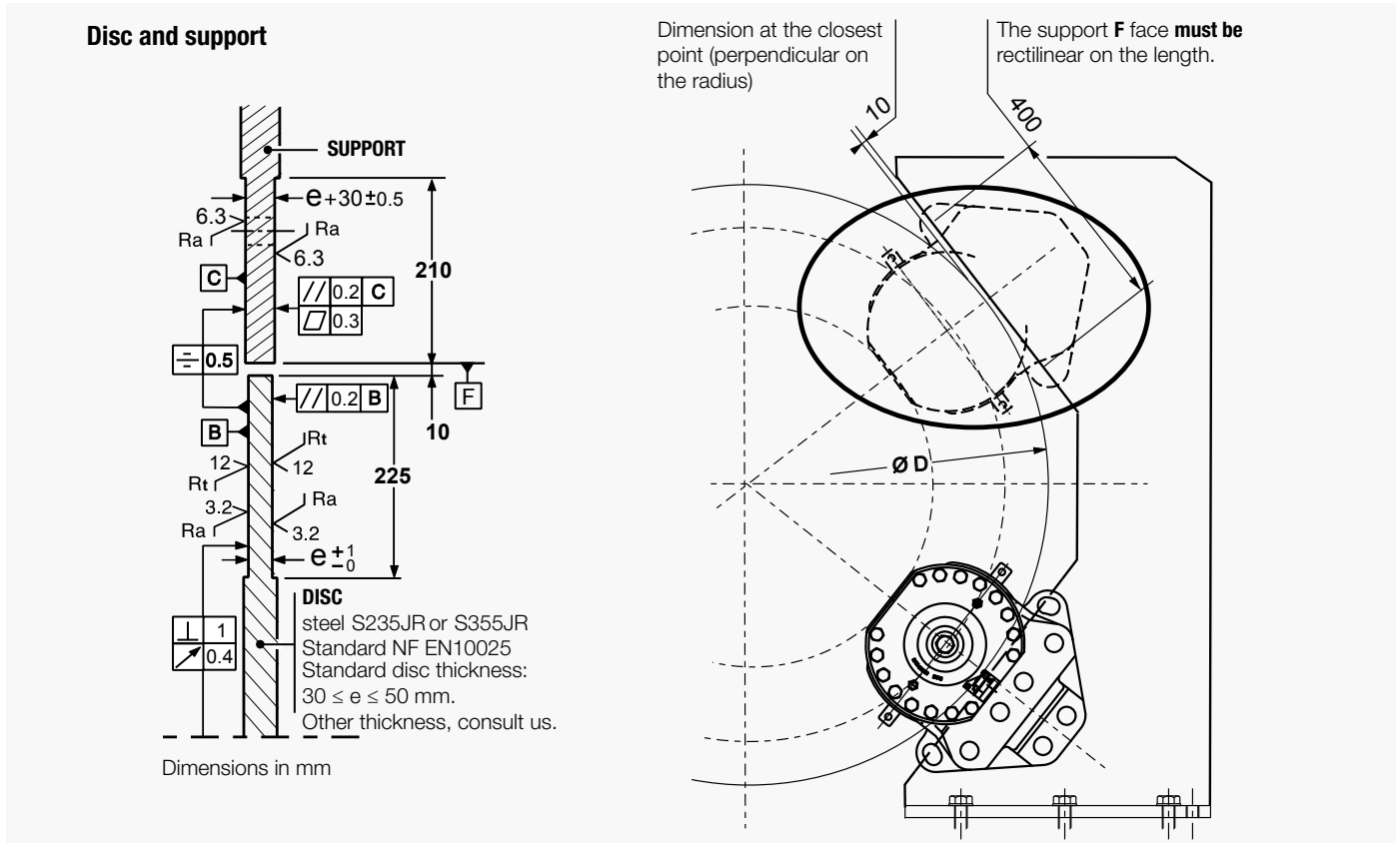

Torque and effort values are subject to a variation of ±10%

Response time at nominal torque : see the leaflet n° G08555-01

Designation	Caliper		SH15-3		SH15-2		SH15-1	
	Lining *		US2-1	US2-4	US2-1	US2-4	US2-1	US2-4
Braking force BF for 1mm of air gap disc/lining	Static	N	133 000	99 000	110 000	80 000	90 000	66 000
	Dynamic	N	150 000	110 000	120 000	88 000	100 000	73 000
Linear speed of the disc		m/s	≤ 10	≤ 50	≤ 10	≤ 50	≤ 10	≤ 50
Dynamic braking torque BT (N.m) for 1 caliper and disc ØD	1000 mm	N.m	61 500	45 100	49 200	36 080	41000	29930
	1200 mm	N.m	76 500	56 100	62 200	44 880	51 000	37 230
	1500 mm	N.m	99 000	72 600	79 200	58 080	66 000	48 180
	2000 mm	N.m	136 500	100 100	109 200	80 080	91 000	66 430
BT for other ØD (mm)		N.m	BT = BF (D/2000 - 0.09)					
Regulation pressure	minimum	bar	150		140		110	
	maximum	bar	180		160		140	
Setting pressure of limit valve of the hydraulic unit		bar	205		205		165	
Total volume of oil displaced		cm³	85 for one stroke disc/lining (nominal wear and opening)					

\* **US2-1**: disc temperature during one braking ≤ 150°C

**US2-4** : disc temperature during one braking ≤ 600°C

**US2-5**: disc temperature during one braking ≤ 350°C, optional, consult us.

# SIME Brakes Industrial Braking Systems

## Emergency Brakes

### DISC BRAKE - SHC15 CALIPER

Revision number: T03906-03-C

Revision date: 29.08.2018

Emergency brake  
Fail safe  
Spring application  
Hydraulic release  
Integral hydraulic power pack  
Opening proving switches  
Lining wear detector

**Operating conditions:**

- Ambient temperature: -10°C to +60°C
- Relative humidity: ≤ 70%
- Dust in atmosphere ≥ 65µ
- Other conditions: consult us.

**Options:**

- Lining wear control switch
- Progressive braking system
- Marine protection
- Self contained electric system

**Use:**

- The brake should be applied only in case of emergency stop, overspeed or shutdown of electric mains. Other use, consult us.

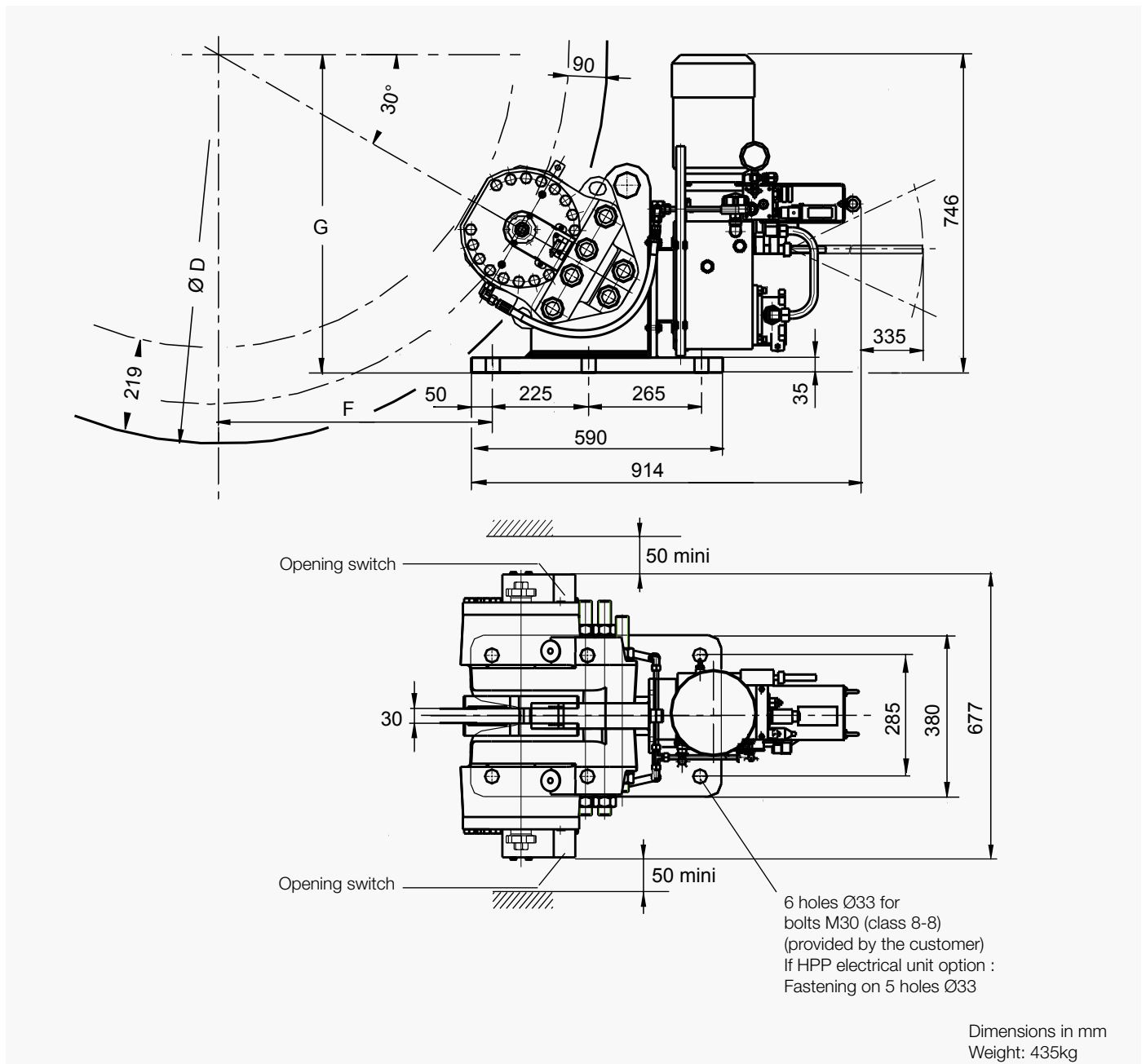

### DISC BRAKE - SHC15 CALIPER

Revision number: T03906-03-C

Revision date: 29.08.2018

#### Installation instructions

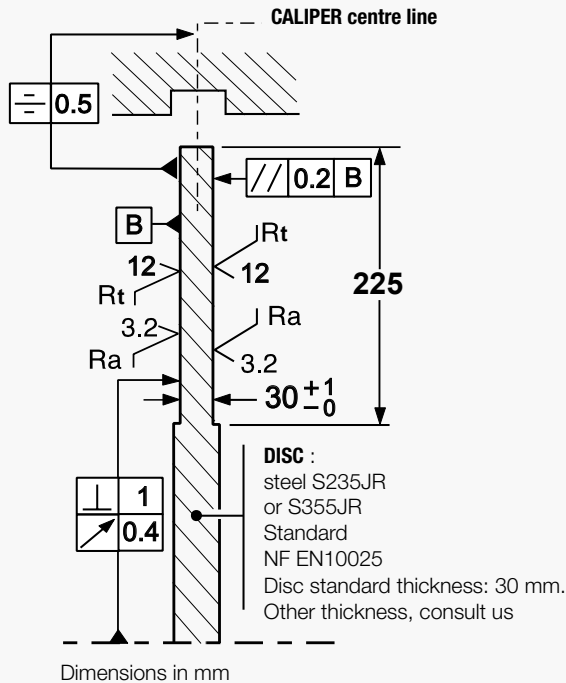

#### Electrical data

- **Motor voltages :**  
 3 phases : 230/400VAC ±10% 50Hz  
 2.2kW, 4 poles
- **Options motor :**  
 690VAC ±10% 50Hz  
 500VAC ±10% 50Hz  
 230/400VAC ±10% 50Hz with PTC sensor  
 Other voltage, consult us.
- **Opening switch :**  
 250VAC maxi., 5A maxi.,  
 with interrupting capacity: 50VA maxi.  
 220VDC maxi., 5A maxi.,  
 with interrupting capacity: 50W maxi.  
 Compatible with PLC  
 (Programmable Logic Controllers).  
 An opening switch used with other equipment  
 than PLC must not be reused with a PLC.

Torque and effort values are subject to a variation of ±10%  
 Response time at nominal torque : see the leaflet n° G08555-01.

Designation	Caliper		SHC15-3		SHC15-2		SHC15-1	
	Lining *		US2-1	US2-4	US2-1	US2-4	US2-1	US2-4
Braking force BF for 1mm of air gap disc/lining	Static	N	133 000	99 000	110 000	80 000	90 000	66 000
	Dynamic	N	150 000	110 000	120 000	88 000	100 000	73 000
Linear speed of the disc		m/s	≤ 10	≤ 50	≤ 10	≤ 50	≤ 10	≤ 50
Dynamic braking torque BT (N.m) for 1 caliper and disc ØD	1000 mm	N.m	61 500	45 100	49 200	36 080	41 000	29 930
	1200 mm	N.m	76 500	56 100	62 200	44 880	51 000	37 230
	1500 mm	N.m	99 000	72 600	79 200	58 080	66 000	48 180
	2000 mm	N.m	136 500	100 100	109 200	80 080	91 000	66 430
BT for other ØD (mm)		N.m	BT = BF (D/2000 - 0.09)					
F		mm	F = (0.433 x D) - 154.2					
G		mm	G = (0.250 x D) + 286.2					
Setting pressure of limit valve of the hydraulic unit		bar	205		205		165	

- \* **US2-1:** disc temperature during one braking ≤ 150°C
- US2-4 :** disc temperature during one braking ≤ 600°C
- US2-5:** disc temperature during one braking ≤ 350°C, optional, consult us.

# SIME Brakes Industrial Braking Systems

## Emergency Brakes

### DISC BRAKE - SH18B CALIPER

Revision number: T03907-01-B

Revision date: 08.10.2010

Emergency brake  
Fail safe  
Spring application  
Hydraulic release  
Opening proving switches  
Lining wear detector

#### Operating conditions:

- Ambient temperature:  $-10^{\circ}\text{C}$  to  $+60^{\circ}\text{C}$
  - Relative humidity:  $\leq 70\%$
  - Dust in atmosphere  $\geq 65\mu$
- Other conditions: consult us.

#### Use:

- The brake should be applied only in case of emergency stop, overspeed or shutdown of electric mains. Other use, consult us.

#### Options:

- Lining wear control switch
- Progressive braking system
- Marine protection
- Caliper on support with integral hydraulic power pack

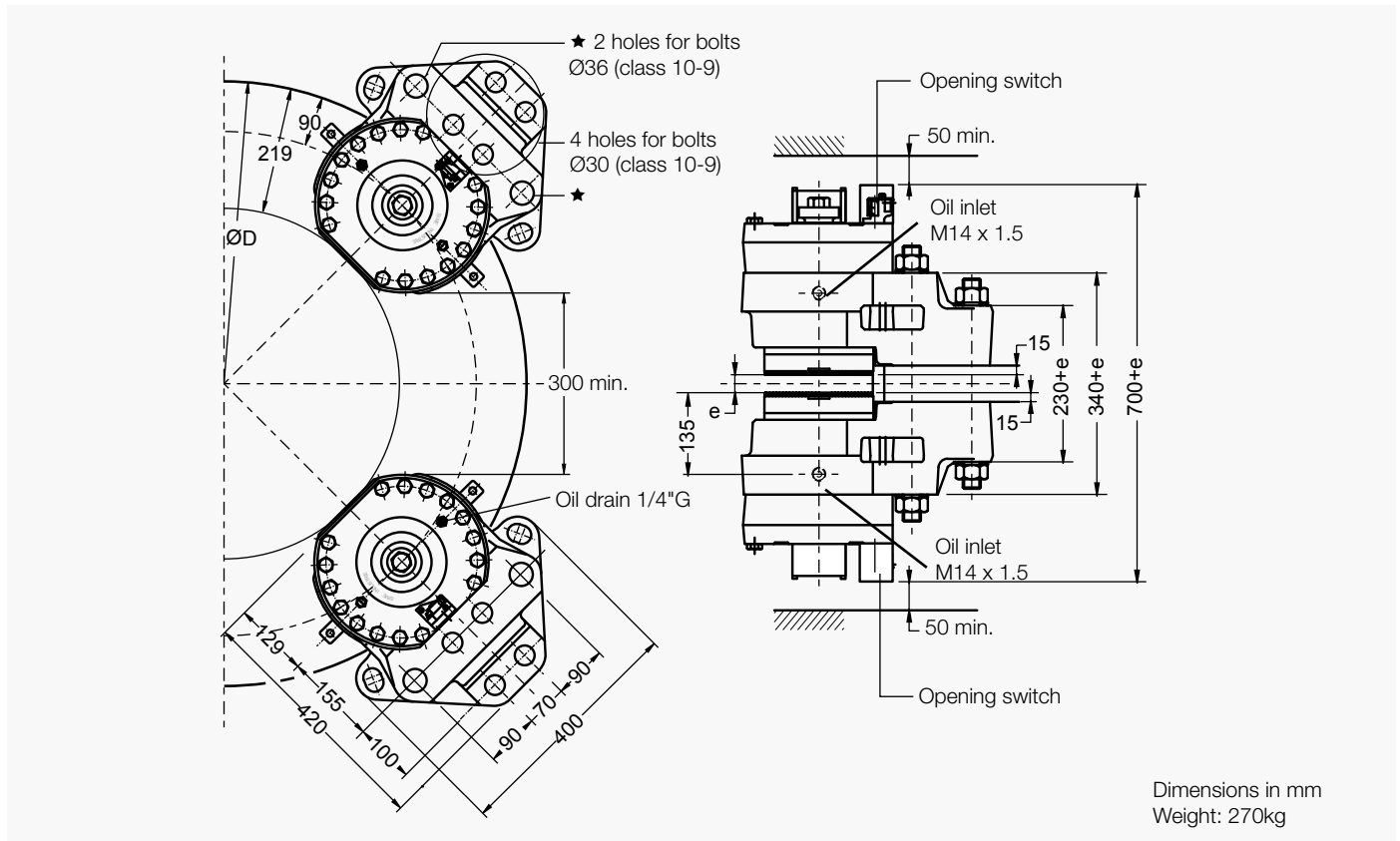

#### Opening proving switch :

250VAC maxi., 5A maxi.,  
with interrupting capacity: 50VA maxi.

220VDC maxi., 5A maxi.,  
with interrupting capacity: 50W maxi.

Compatible with PLC  
(Programmable Logic Controllers).

An opening switch used with other equipment  
than PLC must not be reused with a PLC.



### DISC BRAKE - SH18B CALIPER

Revision number: T03907-01-B

Revision date: 08.10.2010

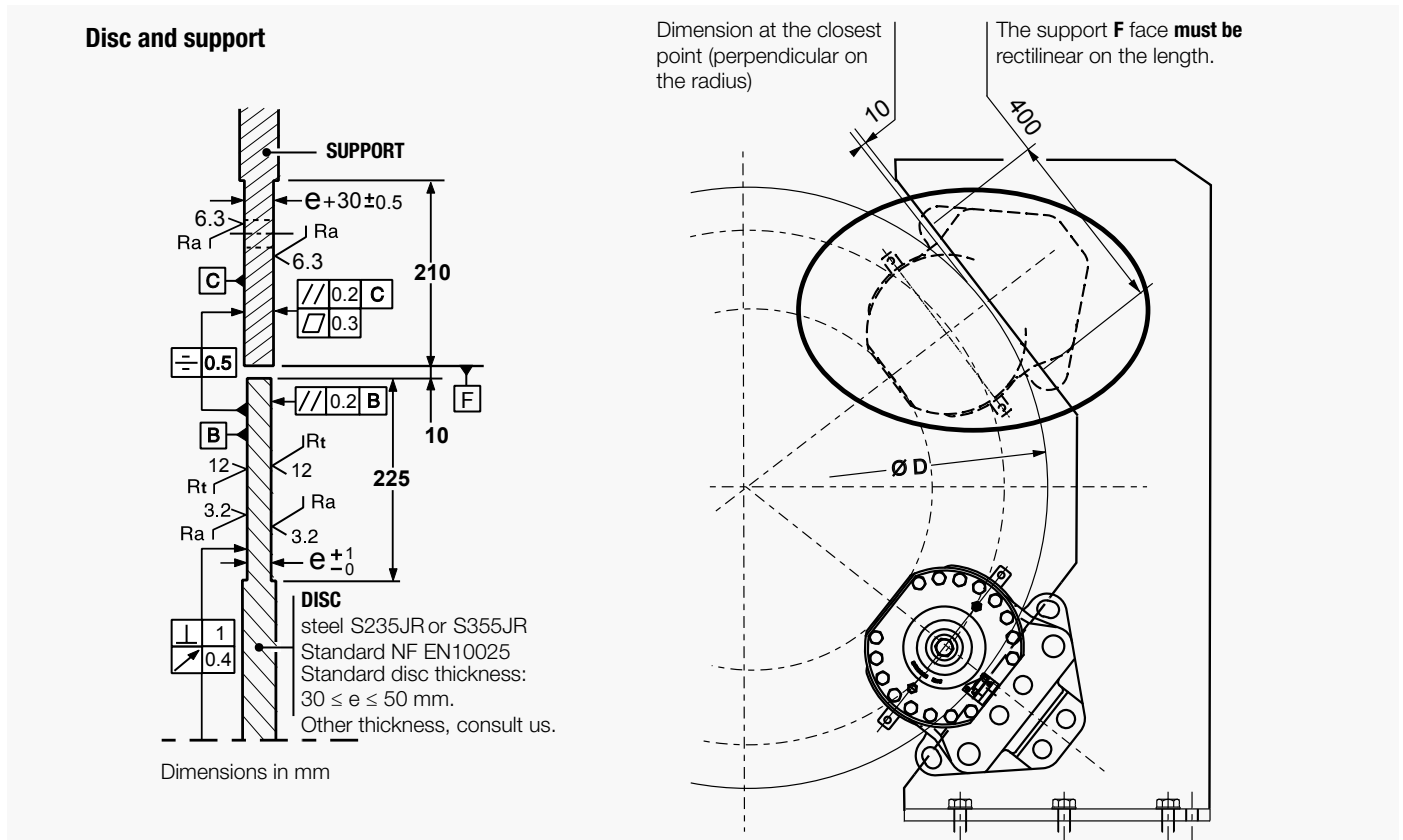

Torque and effort values are subject to a variation of  $\pm 10\%$   
Response time at nominal torque : see the leaflet n° G08555-01

Designation	Caliper		SH18B	
	Lining *		US2-1	US2-4
Braking force BF for 1mm of air gap disc/ lining	Static	N	160 000	117 400
	Dynamic	N	180 000	130 500
Linear speed of the disc		m/s	$\leq 10$	$\leq 50$
Dynamic braking torque BT (N.m) for 1 caliper and disc $\varnothing D$	1000 mm	N.m	73 800	53 500
	1200 mm	N.m	91 800	66 500
	1500 mm	N.m	118 800	86 100
	2000 mm	N.m	163 800	118 700
BT for other $\varnothing D$ (mm)		N.m	BT = BF (D/2000 - 0.09)	
Regulation pressure	minimum	bar	180	
	maximum	bar	200	
Setting pressure of limit valve of the hydraulic unit		bar	225	
Total volume of oil displaced		cm <sup>3</sup>	85 for one stroke disc/lining (nominal wear and opening)	

- \* **US2-1:** disc temperature during one braking  $\leq 150^\circ\text{C}$
- US2-4:** disc temperature during one braking  $\leq 600^\circ\text{C}$
- US2-5:** disc temperature during one braking  $\leq 350^\circ\text{C}$ , optional, consult us.

# SIME Brakes Industrial Braking Systems

## Emergency Brakes

### DISC BRAKE - SHC18B CALIPER

Revision number: T03907-03-B

Revision date: 15.10.2010

Emergency brake  
Fail safe  
Spring application  
Hydraulic release  
Integral hydraulic power pack  
Opening proving switches  
Lining wear detector

**Operating conditions:**

- Ambient temperature: -10°C to +60°C
  - Relative humidity:  $\leq 70\%$
  - Dust in atmosphere  $\geq 65\mu$
- Other conditions: consult us.

**Options:**

- Lining wear control switch
- Progressive braking system
- Marine protection

**Use:**

- The brake should be applied only in case of emergency stop, overspeed or shutdown of electric mains. Other use, consult us.

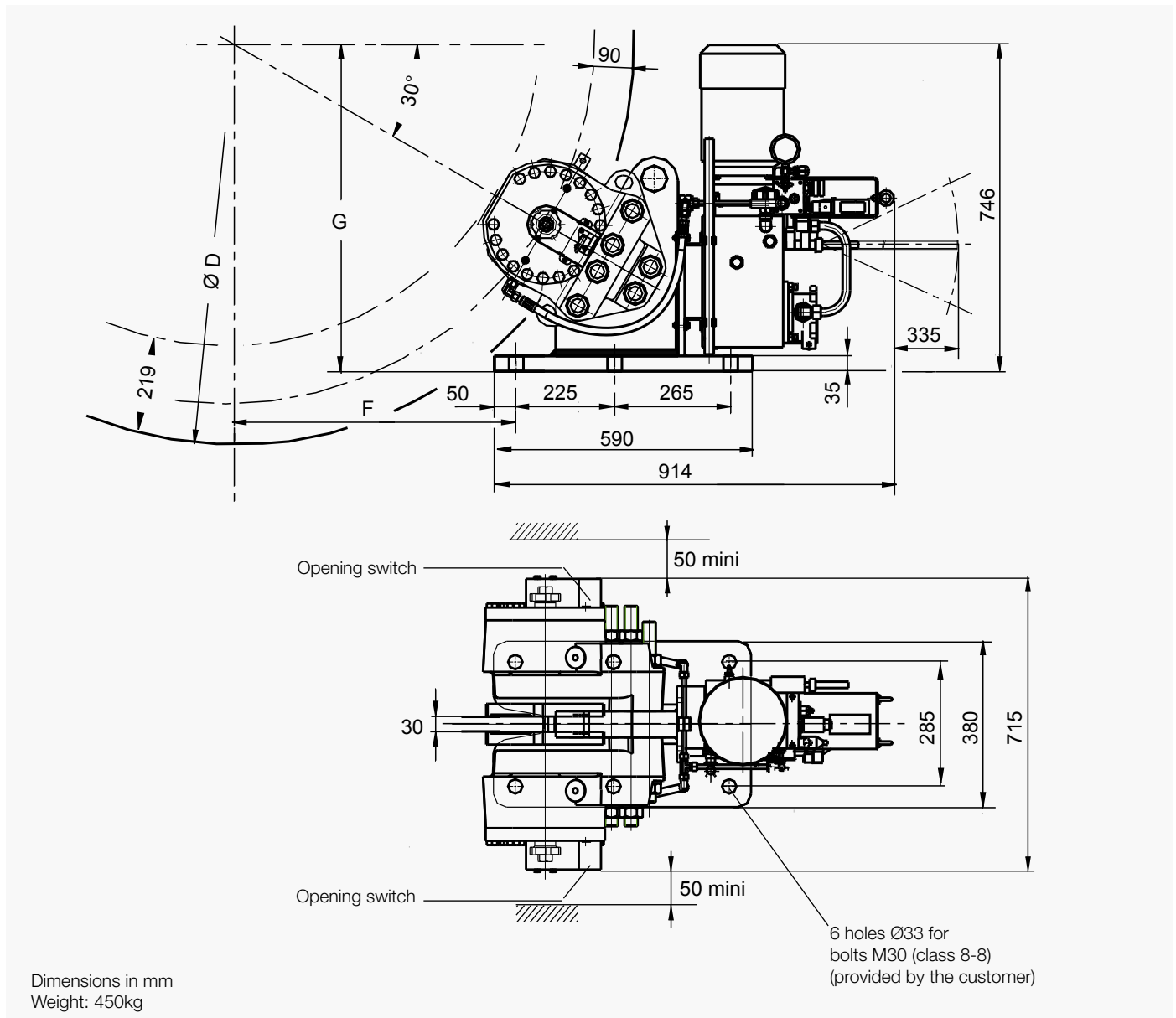

### DISC BRAKE - SHC18B CALIPER

Revision number: T03907-03-B

Revision date: 15.10.2010

#### Installation instructions

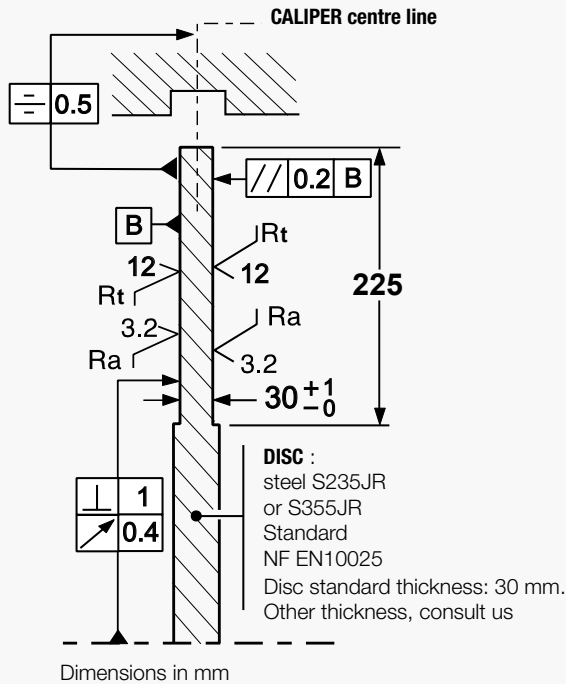

#### Electrical data

- Motor voltages :  
 3 phases : 230/400VAC  $\pm 10\%$  50Hz  
 2.2kW. 4 poles
- Options motor :  
 690VAC  $\pm 10\%$  50Hz  
 500VAC  $\pm 10\%$  50Hz  
 230/400VAC  $\pm 10\%$  50Hz with PTC sensor  
 Other voltage, consult us.
- Opening switch :  
 250VAC maxi., 5A maxi.,  
 with interrupting capacity: 50VA maxi.  
 220VDC maxi., 5A maxi.,  
 with interrupting capacity: 50W maxi.  
 Compatible with PLC  
 (Programmable Logic Controllers).  
 An opening switch used with other equipment  
 than PLC must not be reused with a PLC.

Torque and effort values are subject to a variation of  $\pm 10\%$   
 Response time at nominal torque : see the leaflet n° G08555-01.

Designation	Caliper		SHC18B	
	Lining *		US2-1	US2-4
Braking force BF for 1mm of air gap disc/lining	Static	N	160 000	117 400
	Dynamic	N	180 000	130 500
Linear speed of the disc		m/s	$\leq 10$	$\leq 50$
Dynamic braking torque BT (N.m) for 1 caliper and disc ØD	1000 mm	N.m	73 800	53 500
	1200 mm	N.m	91 800	66 500
	1500 mm	N.m	118 800	86 100
	2000 mm	N.m	163 800	118 700
BT for other ØD (mm)		N.m	BT = BF (D/2000 - 0.09)	
F		mm	F = (0.433 x D) - 154.2	
G		mm	G = (0.250 x D) + 286.2	
Setting pressure of limit valve of the hydraulic unit		bar	225	

\* **US2-1:** disc temperature during one braking  $\leq 150^\circ\text{C}$

**US2-4 :** disc temperature during one braking  $\leq 600^\circ\text{C}$

**US2-5:** disc temperature during one braking  $\leq 350^\circ\text{C}$ , optional, consult us.

# SIME Brakes Industrial Braking Systems

## Emergency Brakes

### DISC BRAKE - SH25 CALIPER

Revision number: T03915-01-B

Revision date: 21.10.2010

Emergency brake  
Fail safe  
Spring application  
Hydraulic release  
Opening proving switches  
Lining wear detector

**Operating conditions:**

- Ambient temperature: -10°C to +60°C
  - Relative humidity: ≤ 70%
  - Dust in atmosphere ≥ 65µ
- Other conditions: consult us.

**Use:**

- The brake should be applied only in case of emergency stop, overspeed or shutdown of electric mains. Other use, consult us.

**Options:**

- Lining wear control switch
- Progressive braking system
- Marine protection
- Caliper on support with integral hydraulic power pack

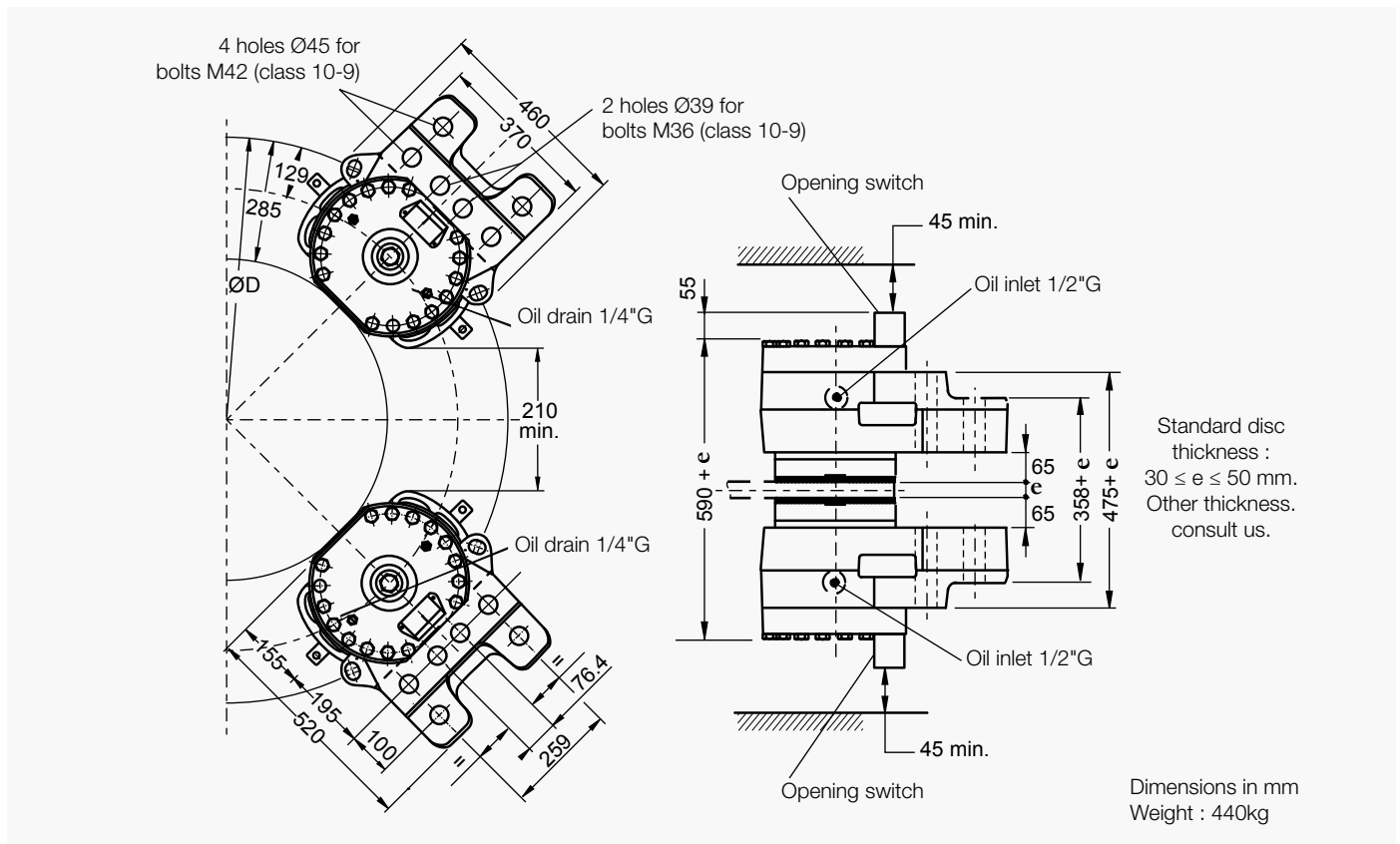

**Opening proving switch :**

250VAC maxi., 5A maxi.,  
with interrupting capacity: 50VA maxi.

220VDC maxi., 5A maxi.,  
with interrupting capacity: 50W maxi.

Compatible with PLC  
(Programmable Logic  
Controllers).

An opening switch used with other equipment  
than PLC must not be reused with a PLC.

### DISC BRAKE - SH25 CALIPER

Revision number: T03915-01-B

Revision date: 21.10.2010

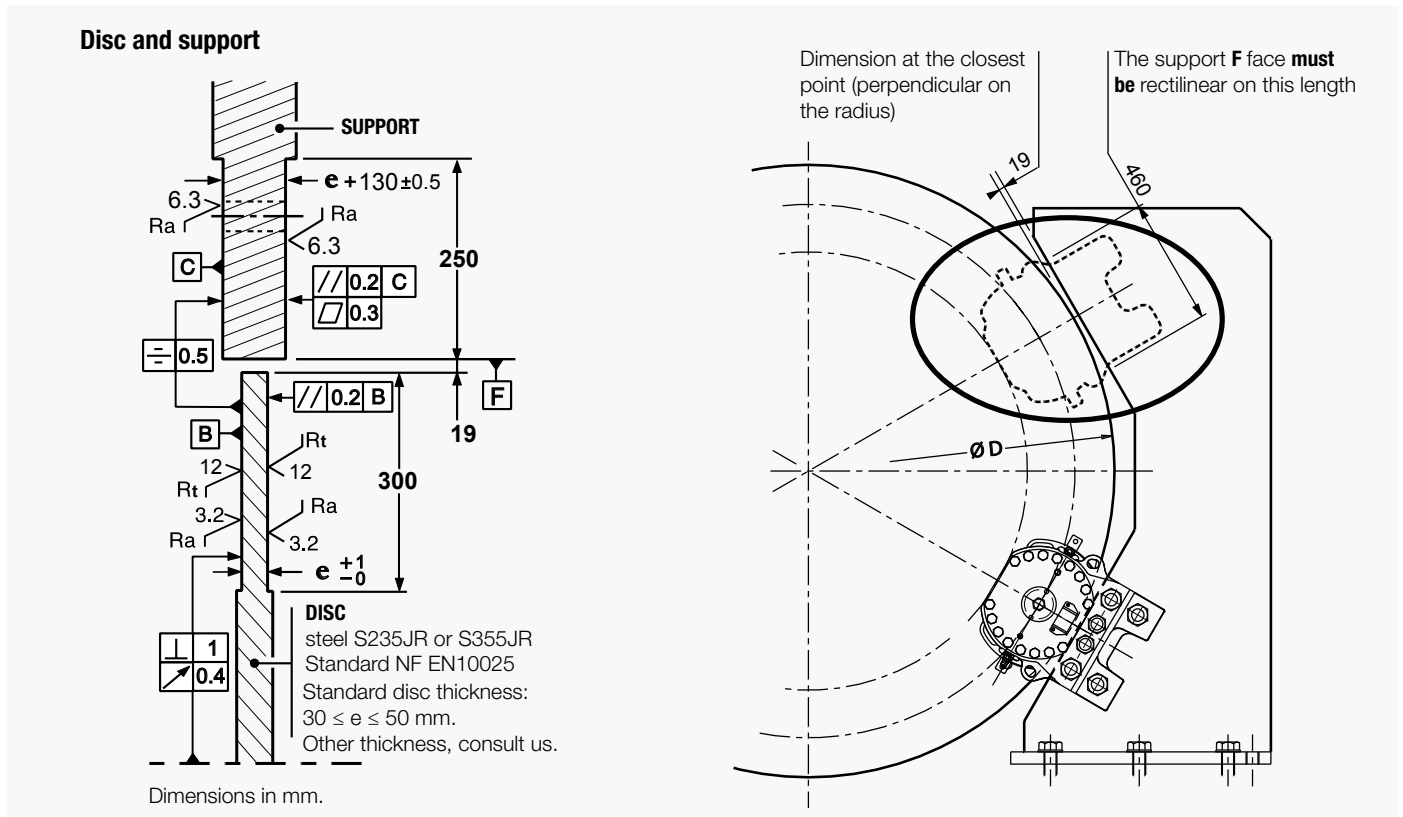

Torque and effort values are subject to a variation of  $\pm 10\%$   
 Response time at nominal torque : see the leaflet n° G08555-01

Designation	Caliper		SH25-2		SH25-1	
	Lining *		US2-1	US2-4	US2-1	US2-4
Braking force BF for 1mm of air gap disc/lining	Static N	N	225 000	165 000	160 000	120 000
	Dynamic N	N	250 000	184 000	180 000	134 000
Linear speed of the disc		m/s	$\leq 10$	$\leq 50$	$\leq 10$	$\leq 50$
Dynamic braking torque BT (N.m) for 1 caliper and disc $\varnothing D$ (mm)	1500 mm	N.m	155 250	114 260	111 780	83 210
	2000 mm	N.m	217 750	160 260	156 780	116 710
	2500 mm	N.m	280 250	206 260	201 780	150 210
	3000 mm	N.m	342 750	252 260	246 780	183 710
BT for other $\varnothing D$ (mm)		N.m	BT = BF (D/2000 - 0.129)			
Regulation pressure	minimum	bar	180		140	
	maximum	bar	200		160	
Setting pressure limit valve of hydraul. Unit		bar	225		205	
Total volume of oil displaced		cm <sup>3</sup>	140 for one stroke disc/lining (nominal wear and opening)			

\* **US2-1:** disc temperature during one braking  $\leq 150^\circ\text{C}$   
**US2-4:** disc temperature during one braking  $\leq 600^\circ\text{C}$   
**US2-5:** disc temperature during one braking  $\leq 350^\circ\text{C}$ , optional, consult us.

# SIME Brakes Industrial Braking Systems

## Emergency Brakes

### DISC BRAKE - SHC25 CALIPER

Revision number: T03916-02-C

Revision date: 15.06.2011

Emergency brake  
Fail safe  
Spring application  
Hydraulic release  
Integral hydraulic power unit  
Opening proving switches  
Lining wear detector

**Operating conditions:**

- Ambient temperature: -10°C to +60°C
  - Relative humidity: ≤ 70%
  - Dust in atmosphere ≥ 65µ
- Other conditions: consult us.

**Options:**

- Lining wear control switch
- Progressive braking system
- Marine protection
- Self contained electric system

**Use:**

- The brake should be applied only in case of emergency stop, overspeed or shutdown of electric mains. Other use, consult us.

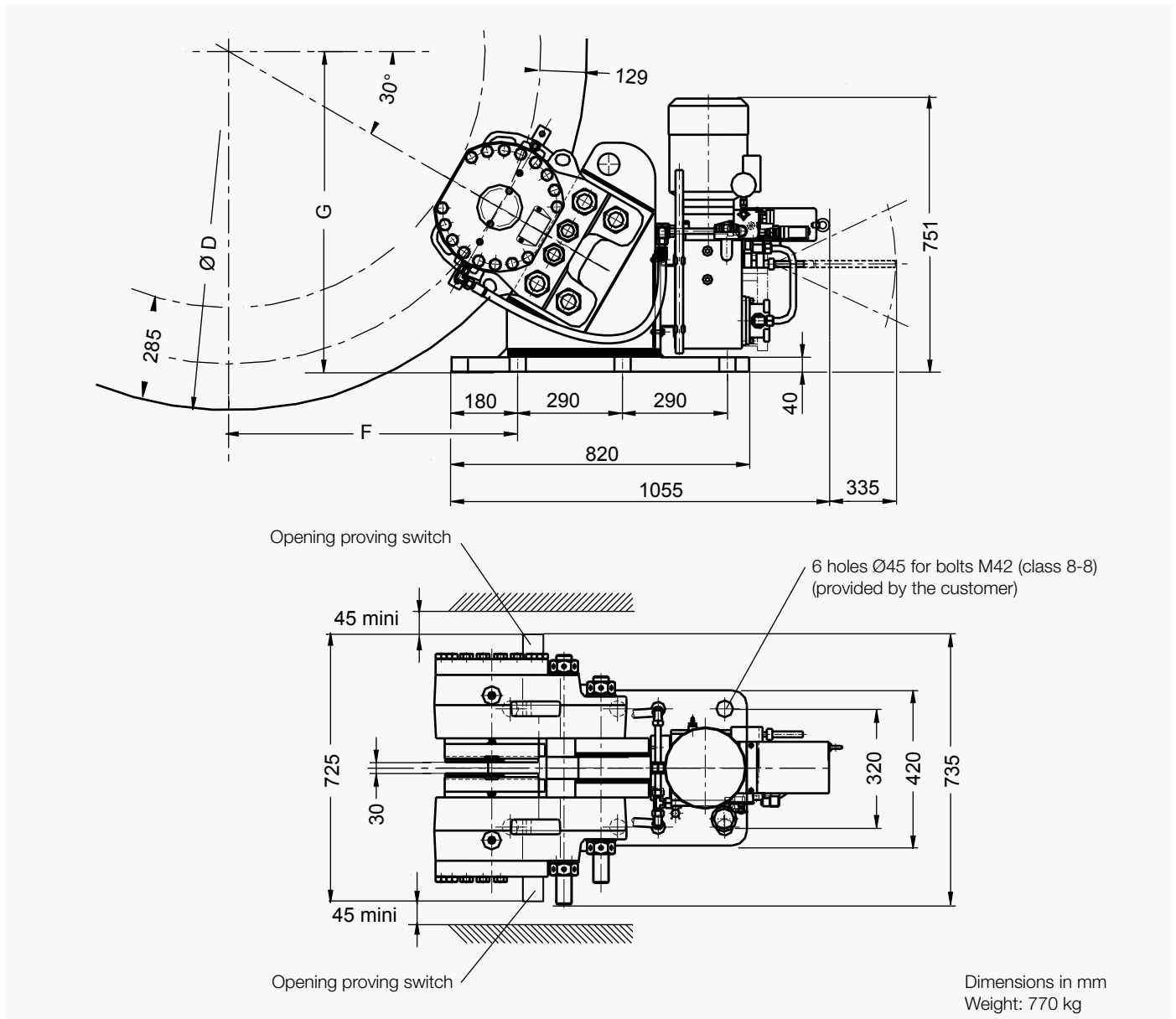

### DISC BRAKE - SHC25 CALIPER

Revision number: T03916-02-B

Revision date: 15.06.2011

#### Installation instructions

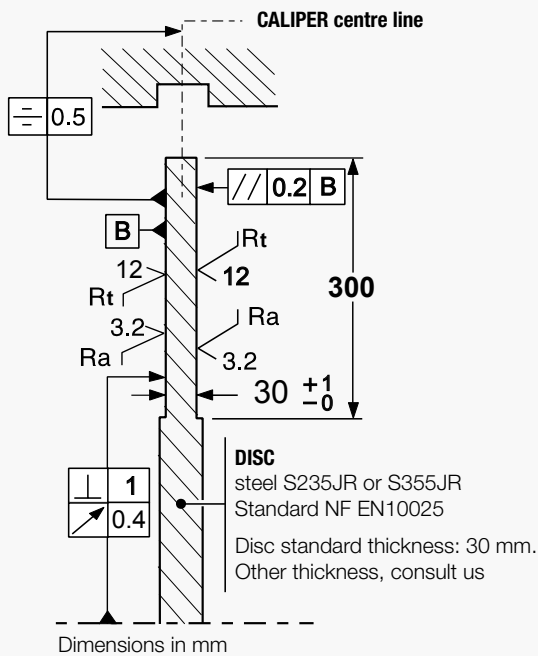

#### Electrical data

- **Motor voltages :**  
3 phases : 230/400VAC  $\pm 10\%$  50Hz  
2.2kW. 4 poles
- **Options motor :**  
690VAC  $\pm 10\%$  50Hz  
500VAC  $\pm 10\%$  50Hz  
230/400VAC  $\pm 10\%$  50Hz with PTC sensor.  
Other voltage, consult us.
- **Opening switch :**  
250VAC maxi., 5A maxi.,  
with interrupting capacity: 50VA maxi.  
220VDC maxi., 5A maxi.,  
with interrupting capacity: 50W maxi.  
Compatible with PLC  
(Programmable Logic Controllers).  
An opening switch used with other equipment  
than PLC must not be reused with a PLC.

Torque and effort values are subject to a variation of  $\pm 10\%$   
Response time at nominal torque : see the leaflet n° G08555-01.

Designation	Caliper		SHC25-2		SHC25-1	
	Lining *		US2-1	US2-4	US2-1	US2-4
Braking force BF for 1mm of air gap disc/lining	Static	N	225 000	165 000	160 000	120 000
	Dynamic	N	250 000	184 000	180 000	134 000
Linear speed of the disc		m/s	$\leq 10$	$\leq 50$	$\leq 10$	$\leq 50$
Dynamic braking torque BF (N.m) for 1 caliper and a disc ØD (mm)	1500 mm	N.m	155 250	114 260	111 780	83 210
	2000 mm	N.m	217 750	160 260	156 780	116 710
	2500 mm	N.m	280 250	206 260	201 780	150 210
	3000 mm	N.m	342 750	252 260	246 780	183 710
BT for other ØD (mm)		N.m	BT = BF (D/2000 - 0.129)			
F		mm	F = (0.433 x D) - 62			
G		mm	G = (0.250 x D) + 390			
Maximum setting pressure limit valve of hydraulic power unit		bar	225		205	

- \* **US2-1** : disc temperature during one braking  $\leq 150^\circ\text{C}$
- US2-4** : disc temperature during one braking  $\leq 600^\circ\text{C}$
- US2-5** : disc temperature during one braking  $\leq 350^\circ\text{C}$ , optional, consult us.

# SIME Brakes Industrial Braking Systems

## Emergency Brakes

### DISC BRAKE - SH32 CALIPER

Revision number: T10040-01-C

Revision date: 15.06.2012

Emergency brake  
Fail safe  
Spring application  
Hydraulic release  
Opening proving switches  
Lining wear indicator wires

**Operating conditions:**

- Ambient temperature: -10°C to +60°C
  - Relative humidity: ≤ 70%
  - Dust in atmosphere ≥ 65µ
- Other conditions: consult us.

**Use:**

- The brake should be applied only in case of emergency stop, overspeed or shutdown of electric mains. Other use, consult us.

**Options:**

- Lining wear proving switches
- Progressive braking system
- Marine protection

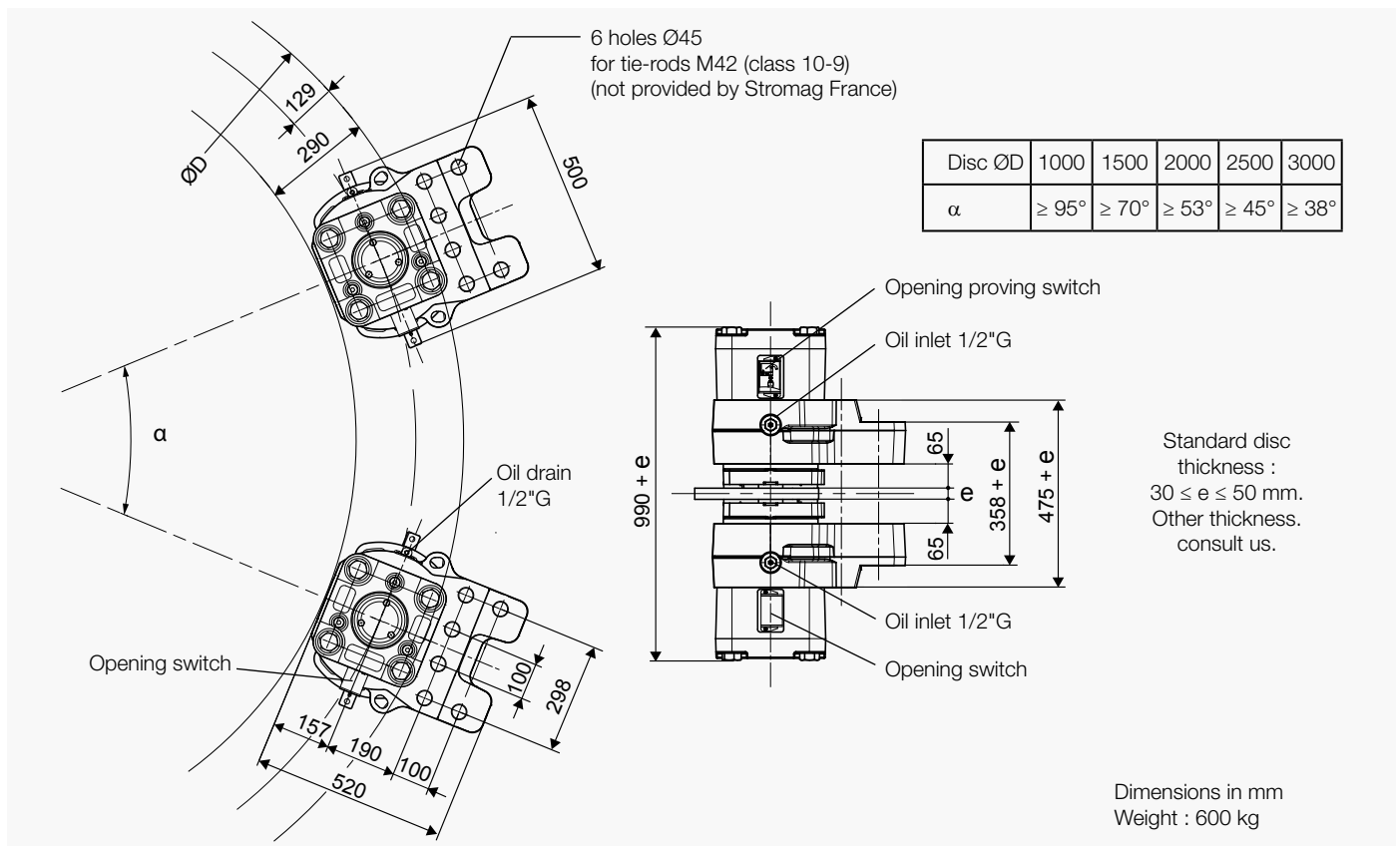

**Opening proving switches**

**Wear proving switches (optional) :**

250VAC maxi., 5A maxi.,  
with interrupting capacity: 50VA maxi.

220VDC maxi., 5A maxi.,  
with interrupting capacity: 50W maxi.

Compatible with PLC (Programmable Logic Controllers).

An opening switch used with other equipment than PLC must not be reused with a PLC.



### DISC BRAKE - SH32 CALIPER

Revision number: T10040-01-C

Revision date: 15.06.2012

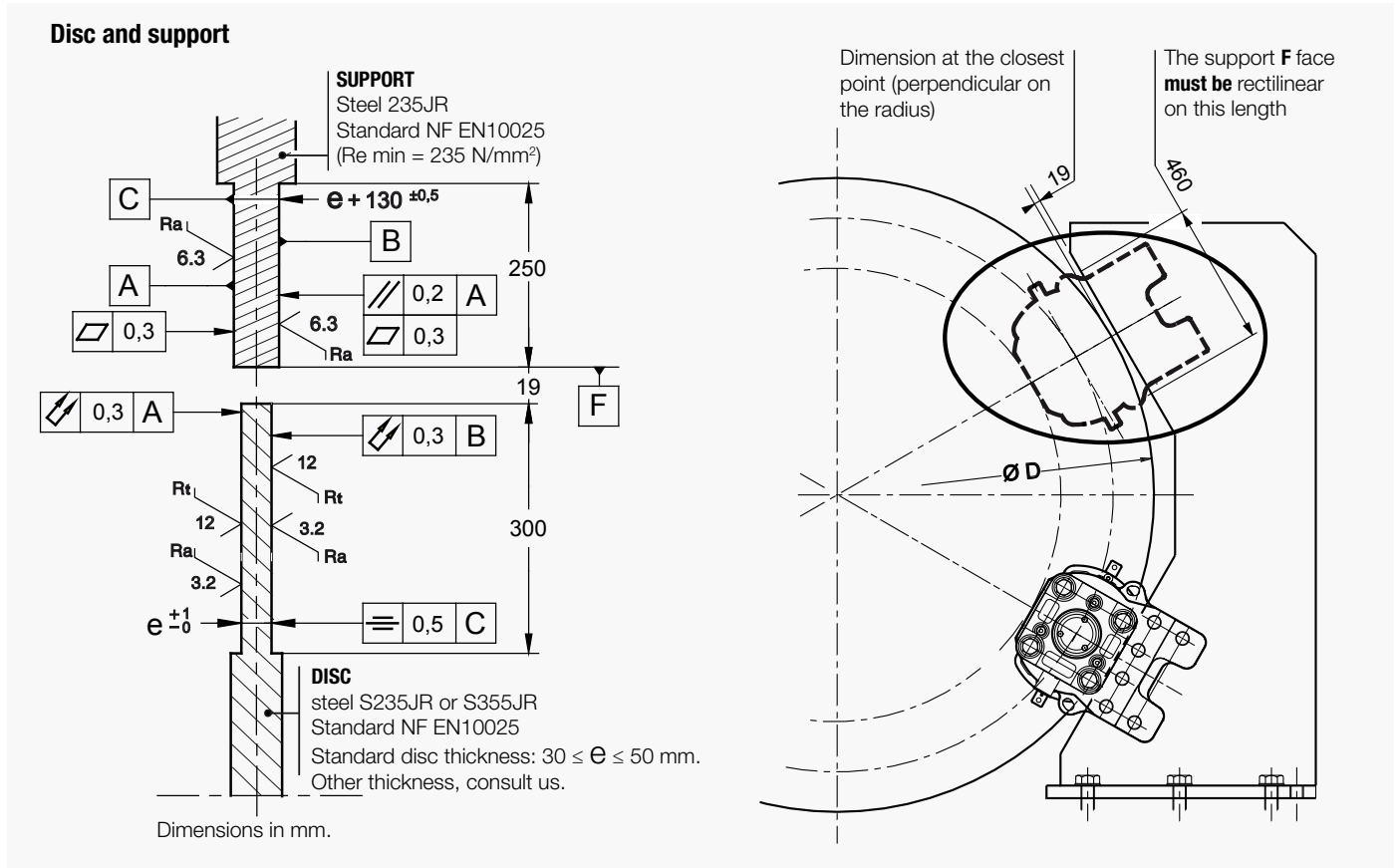

#### IMPORTANT

**BRAKING FORCE** and **TORQUE** values correspond to lining quality **US2-1** and disc steel S235JR or S355JR (standard NF EN10025), these values are subject to a variation of  $\pm 10\%$ .

Response time at nominal torque  $\leq 0.3s$

Designation	Caliper		SH32
	Lining		US2-1
<b>BRAKING FORCE</b> BF for air gap disc/lining of <b>2 x 1.5 mm</b>	<b>Dynamic</b>	N	<b>333 800</b>
	Static	N	300 000
<b>BRAKING FORCE</b> BF for air gap disc/lining of <b>2 x 2 mm</b>	<b>Dynamic</b>	N	<b>320 000</b>
	Static	N	288 000
Linear speed of the disc		m/s	$\leq 10$
<b>DYNAMIC BRAKING TORQUE</b> BT for 1 caliper and disc $\varnothing D$ (mm)		N.m	$BT = BF (D/2000 - 0.129)$
Regulation pressure	minimum	bar	180
	maximum	bar	200
Setting pressure limit valve of hydraulic unit		bar	225
Total volume of oil displaced for air gap disc/lining of 2 x 2 mm		cm <sup>3</sup>	191 for one stroke disc/lining

# SIME Brakes Industrial Braking Systems

## Emergency Brakes

### APPLICATIONS

<p><b>SHD:</b></p> <ul style="list-style-type: none"><li>• TOWER CRANES - BOOM CRANES</li><li>• OFFSHORE APPLICATIONS</li><li>• WINDTURBINES</li></ul>	<p><b>TH/THC9:</b></p> <ul style="list-style-type: none"><li>• AERONAUTIC APPLICATIONS</li><li>• PORT CRANES</li></ul>
--	--

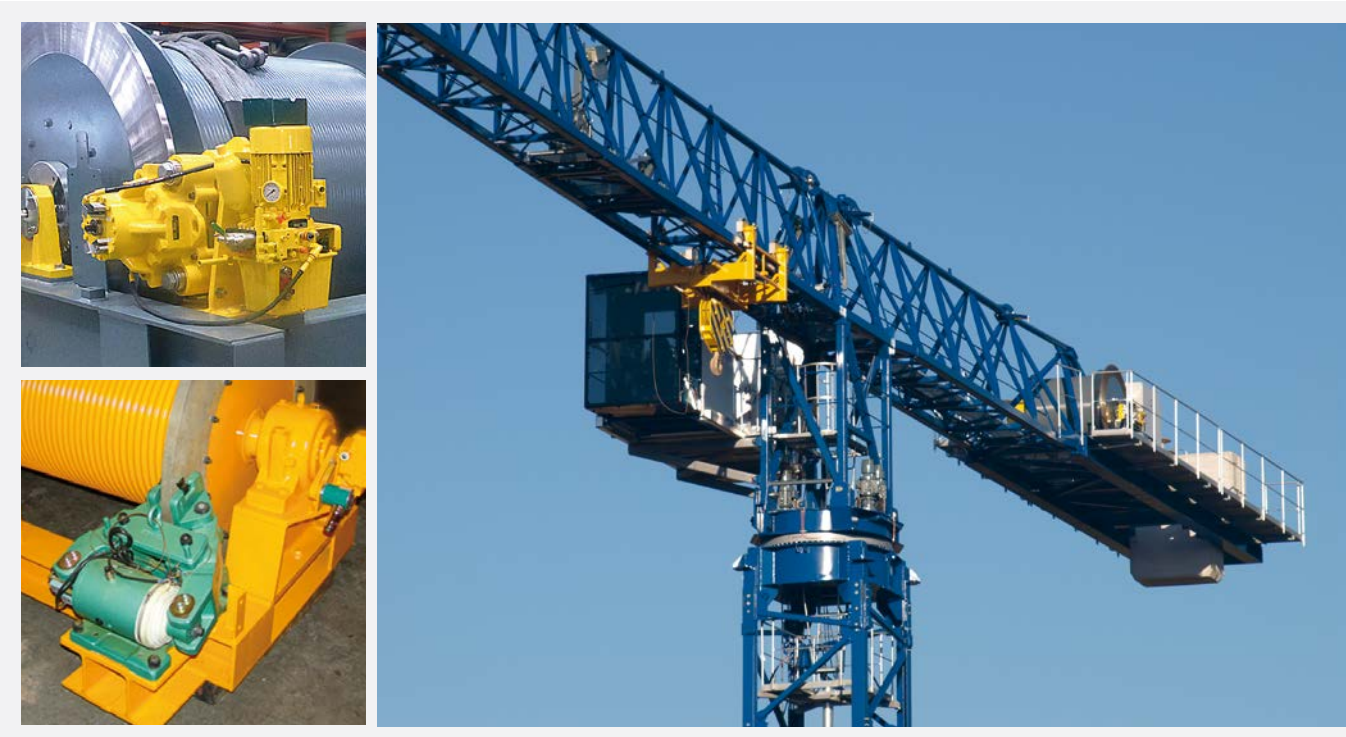

Photo courtesy of Comansa - Special project

--	--	--	--

### HYDRAULIC EMERGENCY BRAKES TYPES SHD / TH

MAIN CHARACTERISTICS	OPTIONS
<ul style="list-style-type: none"> <li>• FAILSAFE BRAKE BY SPRING APPLICATION.</li> <li>• HYDRAULIC RELEASE</li> <li>• OPENING PROVING SWITCH</li> <li>• LINING WEAR INDICATORS</li> </ul>	<ul style="list-style-type: none"> <li>• LINING WEAR PROVING SWITCH</li> </ul>



**SHD**

- Single-spring hydraulic caliper
- A large range from SHD1 to SHD18
- Options:  
Automatic lining wear compensation  
Manual release tool - Positive braking  
Integrated HPP - Marine protection



**TH9**

- Option :  
Disc thickness 42 mm



**THC9**

- Caliper and Hydraulic Power Pack mounted on the same support
- Option: Electrical unit

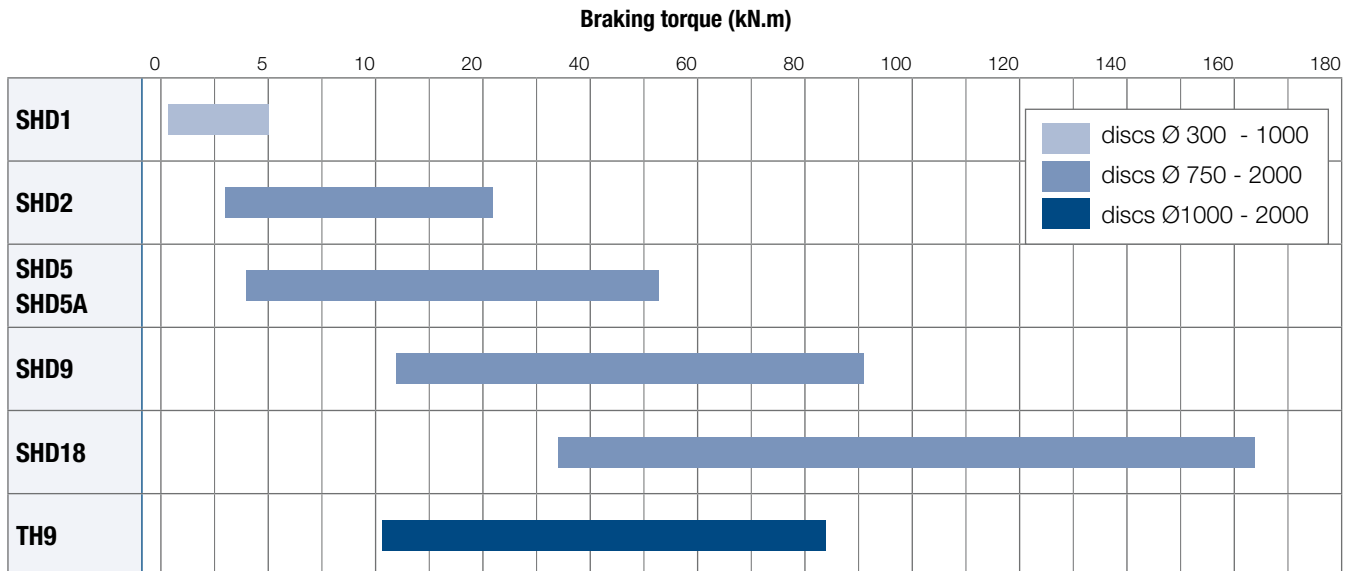

## Emergency Brakes

### DISC BRAKE - SHD1 CALIPER

Revision number: T10098-01-F

Revision date: 05.06.2019

Emergency brake

Fail to safe

Spring application

Hydraulic release

Mechanical holding of the brake in open position for pads changing

Manual wear centering and compensation

Possible association with discs thickness: 12.7 (1/2"), 20 and 30mm.

Lining pads type **US2-1** or **ES3-7**

Lining pads with full wear indicators

Protection C5-M M

#### Operating conditions:

- Ambient temperature:  
Dynamic braking : -30°C to +70°C  
Brake applied (parking): -40°C to +70°C
  - Relative humidity: ≤ 70%
  - Dust in atmosphere ≥ 65µm
- Other conditions: consult us.

#### Use:

- The brake should be applied only in case of emergency stop, overspeed or shutdown of electric mains. Other use, consult us.

#### Options:

- Opening proving switch (**OS**)
- Lining wear proving switch (**WS**)
- All non-standard disc thickness > 12.7mm (1/2")
- Lining temperature sensor (**T**)
- Mechanical release tool (**DM**)
- **SHD1L** : caliper with manual wear compensation at half wear:
  - braking force before wear = +10% maxi.
  - braking force at half wear = -10% maxi.

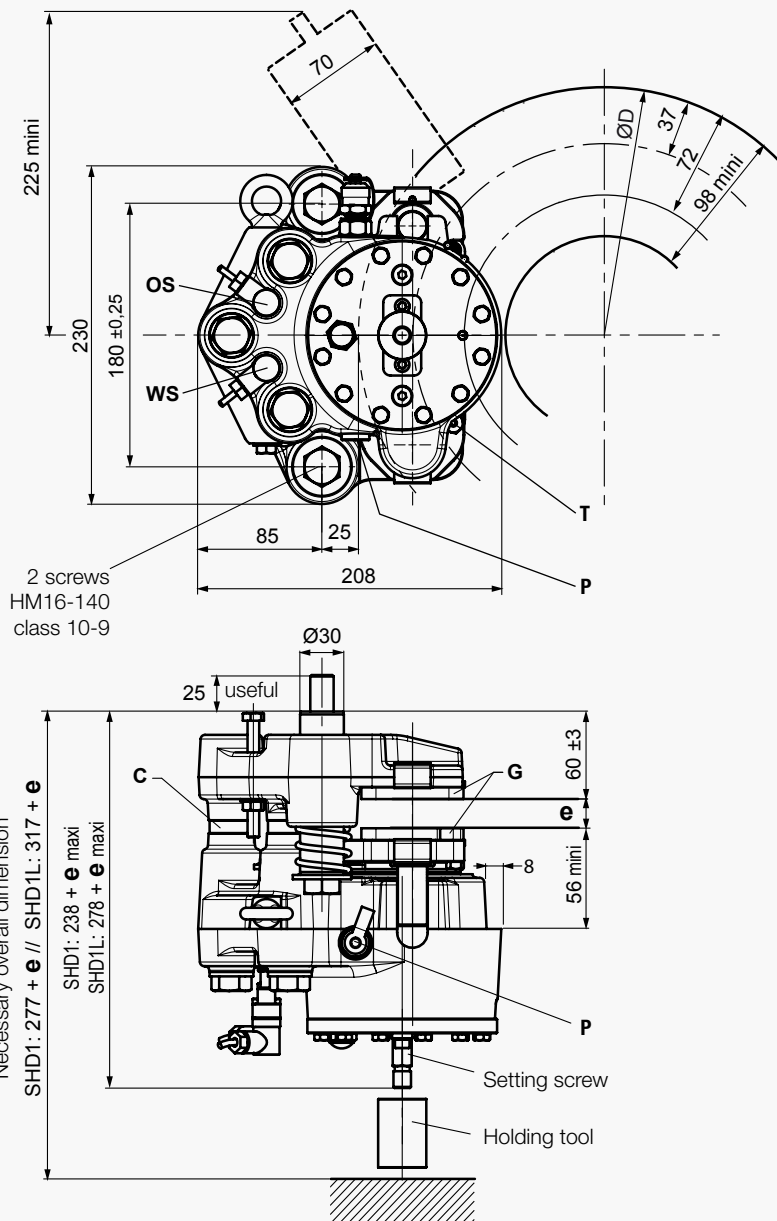

**C** = Spacers according to disc thickness  
**G** = Linings : Thickness of new lining 8 mm  
 Thickness to wear 6 mm  
 Each 1 mm of wear on each side:  
 manual centering and compensation  
**OS** = Opening proving switch (option)  
**WS** = Wear proving switch (option)  
**P** = 2 oil ports 1/4"G  
 Bleeder screw delivered separately  
**T** = PT100 sensor (option)  
**ØD** : from 300 to 1000 mm  
**e** = disc thickness

Dimensions in mm  
 Weight = 24 kg

#### Electrical data

Inductive switches of opening and wear (options):

3 wires PNP NO  
 12 to 24 VDC 200mA  
 with connector M12 / 5 positions  
 according to standard :  
 IEC61076-2-101 / code A

Sensor PT100 (option)

Detection of the temperature threshold :  
 100°C ± 5

- R = 136.6 Ω at 95 °C
- R = 138.5 Ω at 100°C
- R = 140.4 Ω at 105°C

Cable length = 2.5 meters  
 2 wires red/yellow

### DISC BRAKE - SHD1 CALIPER

Revision number: T10098-01-F

Revision date: 05.06.2019

#### Installation instructions :

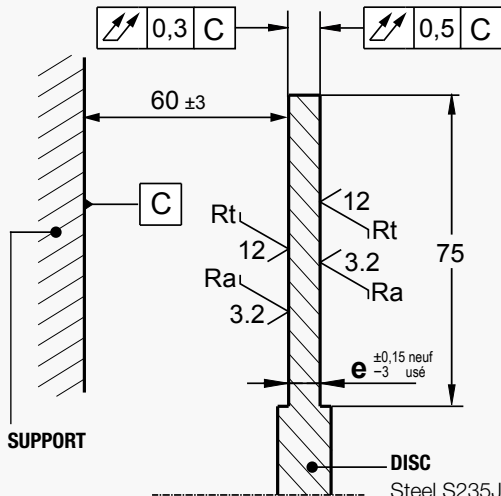

DISC  
Steel S235JR or S355JR  
Standard NF EN10025

Standard disc thickness :  
 $e = 12.7 (1/2")$ , 20 and 30 mm<sup>-3</sup>  
Other thickness, consult us.

#### Support machining tolerances :

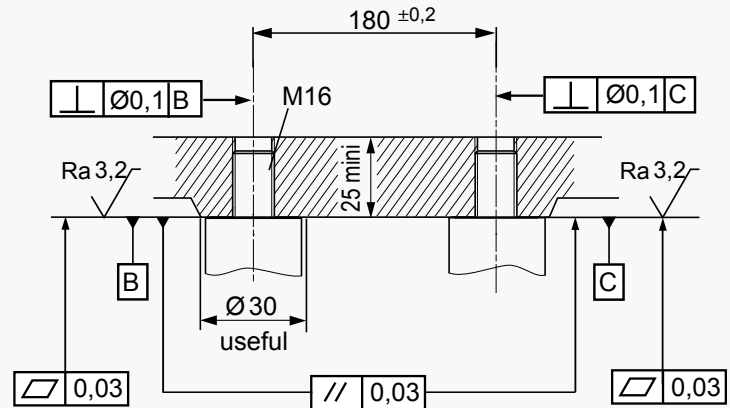

Torque and effort values are subject to a variation of ±10%  
Closing time at nominal torque ≤ 0.3s

Designation	Caliper SHD1-		5	4	3	2	1	5	4	3	2	1
	Lining *		ES3-7					US2-1				
Braking force BF for air gap disc/lining of 2x1mm	Dynamic	N	11 000	8 000	6 000	4 000	2 000	11 000	8 000	6 000	4 000	3 000
	Static	N	9 900	7 200	5 400	3 600	1 800	9 680	7 040	5 280	3 520	2 640
Linear speed of the disc ●		m/s	≤ 50					≤ 10				
Dynamic braking torque BT (m.N) for 1 caliper and disc ØD (mm) / 300 ≤ D ≤ 1000 mm		N.m	BT = BF (D/2000-0.037)									
Regulation pressure	Minimum	bar	150									
	Maximum	bar	170									
Setting pressure limit valve of hydraulic unit		bar	190									
Total volume of oil displaced for air gap disc/lining of:	2 x 1mm (nominal opening)		5 cm <sup>3</sup>									
	2 x 2mm (wear+opening)	cm <sup>3</sup>	9 cm <sup>3</sup>									
	2 x 4mm SHD1L (wear+open.)	cm <sup>3</sup>	18 cm <sup>3</sup>									

\* ES3-7: disc temperature during one braking ≤ 600°C

US2-1: disc temperature during one braking ≤ 100°C

● For higher speed, consult us.

# SIME Brakes Industrial Braking Systems

## Emergency Brakes

### DISC BRAKE - SHD2 CALIPER

Revision number: T03851-05-B

Revision date: 04.09.2012

Spring application  
 Hydraulic release  
 Opening proving switch (compatible for PLC)  
 Lining wear proving switch (compatible for PLC)  
 Marine protection

**Working conditions:**

- Ambient temperature: -20°C to +60°C
- Relative humidity ≤ 70%
- Dust in atmosphere ≥ 65µ
- Other conditions, consult us.

**Use:**

- Emergency stopping brake in case of overspeed or loss of electrical supply

**Options :**

- Thermistors for detection of the maximum temperature of the disc

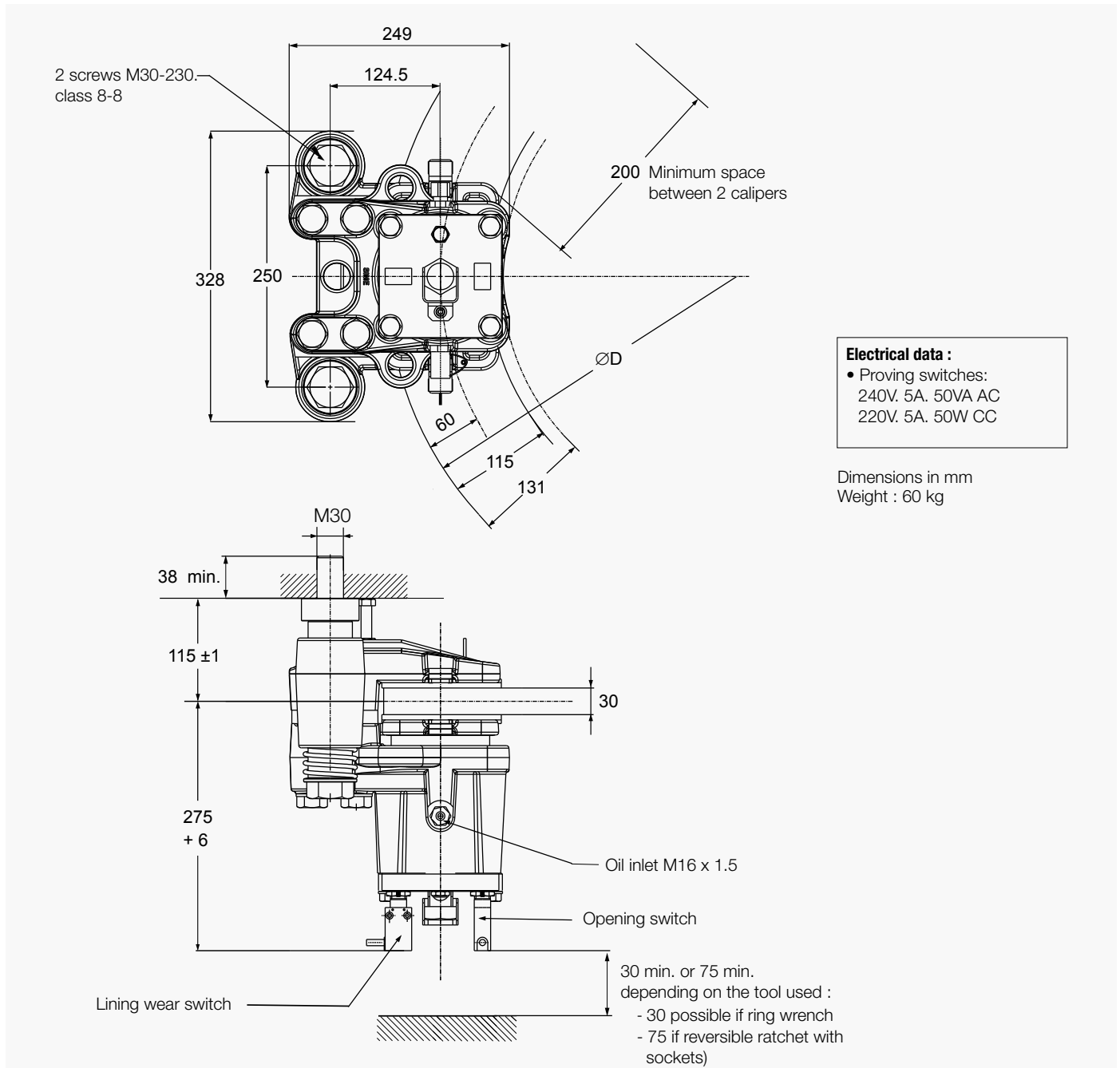

### DISC BRAKE - SHD2 CALIPER

Revision number: T03851-05-B

Revision date: 04.09.2012

#### Installation instructions :

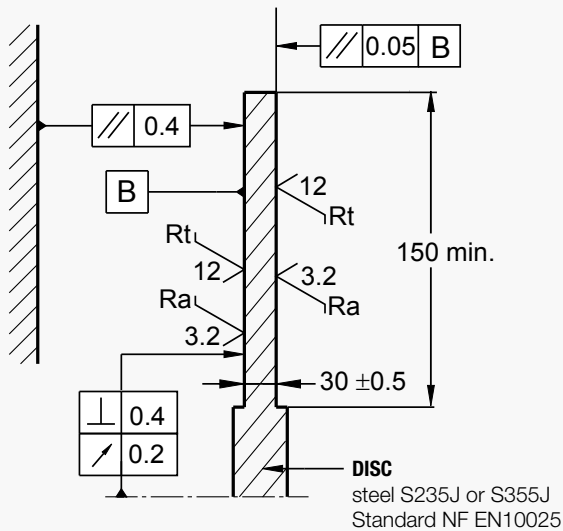

#### Support machining tolerances :

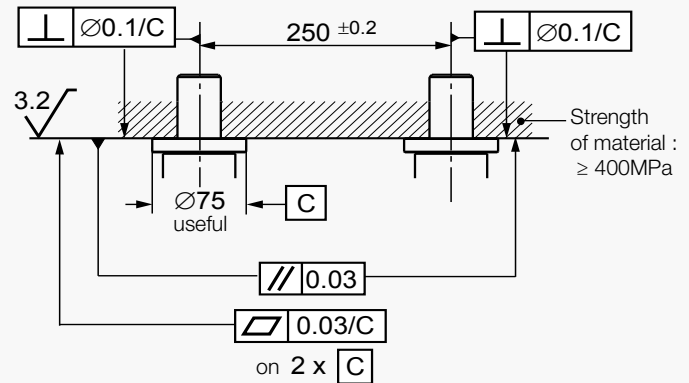

Response time at nominal torque < 0.3s  
Torque and effort values are subject to a variation of  $\pm 10\%$

Designation	Caliper		SHD2-3	SHD2-2	SHD2-1
	Lining		ES3-7		
<b>Braking force BF</b> for air gap disc/lining of 2x1mm	<b>Dynamic</b>	N	23 000	15 400	10 540
Linear speed of the disc ●		m/s	< 50		
<b>Dynamic braking torque BT (m.N)</b> for 1 caliper and disc $\varnothing D$ (mm)	630 mm	N.m	5 870	3 930	2 690
	710 mm	N.m	6 790	4 540	3 110
	800 mm	N.m	7 820	5 240	3 580
	1000 mm	N.m	10 120	6 780	4 640
		N.m	BT = BF (D/2000 - 0.06)		
Regulation pressure	Minimum	bar	180	110	85
	Maximum	bar	200	140	115
Setting pressure limit valve of hydraulic unit		bar	210	165	140
Total volume of oil displaced		cm <sup>3</sup>	8 per stroke (for a nominal disc/lining stroke of 1 mm per side)		
Max. oil volume of the jack		cm <sup>3</sup>	45		

● For higher speed, consult us.

# SIME Brakes Industrial Braking Systems

## Emergency Brakes

### DISC BRAKE - SHD5 CALIPER

Revision number: T03861-08-A

Revision date: 29.11.2010

Fail safe braking  
Braking by spring application  
Hydraulic release  
Opening proving switch  
Lining wear proving switch

**Working conditions:**

- Ambient temperature: -20°C to +60°C
- Relative humidity ≤ 70%
- Dust in atmosphere ≥ 65µ
- Other conditions, consult us.

**Use:**

- Emergency stopping brake in case of overspeed or loss of electrical supply

**Options:**

- Automatic lining wear compensation (WACS)
- Manual release tool (DM)
- Positive braking
- Detection of full lining wear
- Temperature detection of the linings
- Switch for PLC
- Marine protection

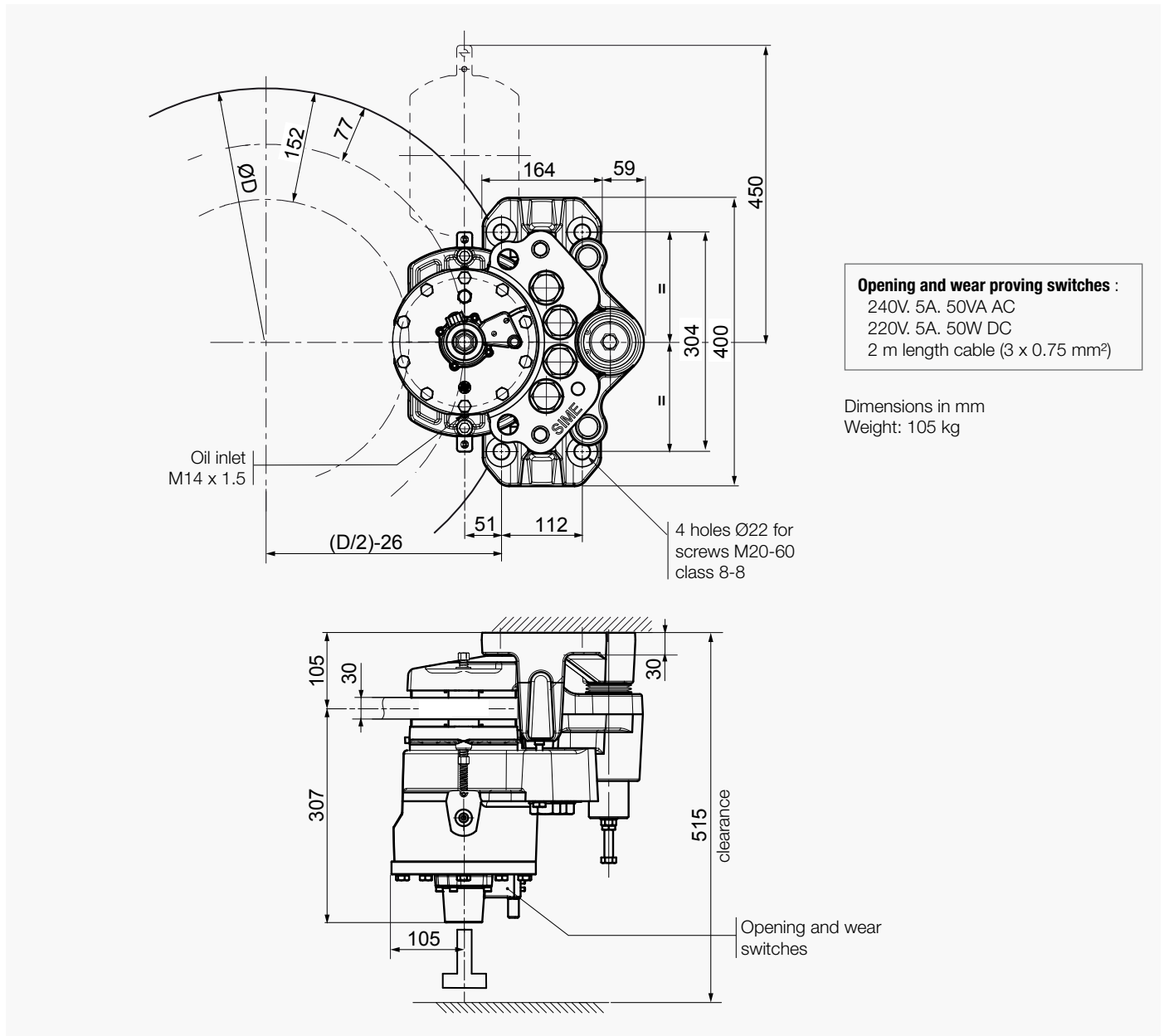



### DISC BRAKE - SHD5 CALIPER

Revision number: T03861-08-A

Revision date: 29.11.2010



Option: Manual release tool DM

#### Installation instructions :

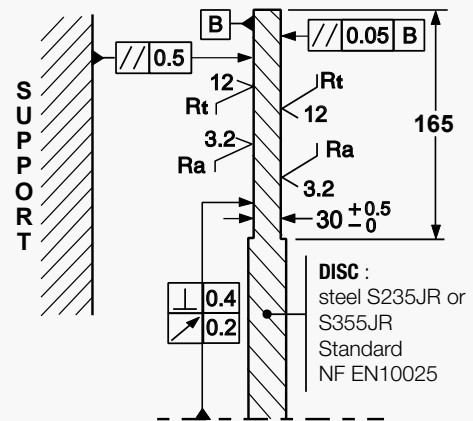

Torque and effort values are subject to a variation of  $\pm 10\%$   
 Response time at nominal torque  $\leq 0.3s$

Designation	Caliper		SHD5-6	SHD5-5	SHD5-4	SHD5-3	SHD5-2	SHD5-1
	Lining		WS1-3					
Braking force BF for 1.25 mm of air gap disc/lining	Dynamic	N	33 000	27 000	23 000	18 000	15 000	13 500
Linear speed of the disc for BF		m/s	< 50					
Dynamic braking torque BT (N.m) for a caliper mounted on a disc ØD (mm)	710 mm	N.m.	9 180	7 500	6 400	5 000	4 170	3 760
	1000 mm	N.m.	13 960	11 420	9 730	7 610	6 350	5 720
	1500 mm	N.m.	22 210	18 170	15 480	12 110	10 100	9 090
		N.m	BT = BF (D/2000 - 0.077)					
Regulation pressure	Min.	bar	110	110	85	60	60	60
	Max.	bar	140	140	115	80	80	80
Setting pressure limit valve hydraul. pack		bar	165	165	140	105	105	105
Total volume of oil displaced		cm <sup>3</sup>	15.9 per stroke (for nominal disc/lining stroke of 1.25 mm per side)					
Max. oil volume of the jack		cm <sup>3</sup>	76					

## Emergency Brakes

### DISC BRAKE - SHD5A-M2 CALIPER

Revision number: T10131-02-E

Revision date: 27.09.2018

Fail safe braking  
 Braking by spring application  
 Hydraulic release  
 Opening proximity switch  
 Holding tool  
 Detection of full lining wear  
 Protection level C3-H standard ISO 12944-2  
 VCI packing

**Working conditions:**

- Ambient temperature: -10°C to +60°C
- Relative humidity ≤ 70%
- Dust in atmosphere ≥ 65µ
- Other conditions. consult us.

**Use:**

- Emergency stopping brake in case of overspeed or loss of electrical supply
- Service life : 200 000 cycles

**Options:**

- Wear proximity switch
- Closing proximity switch
- Low temperature:
  - dynamic braking: -30°C to +60°C
  - brake closed (park position): -40°C to +60°C
- Protection level C5M-H

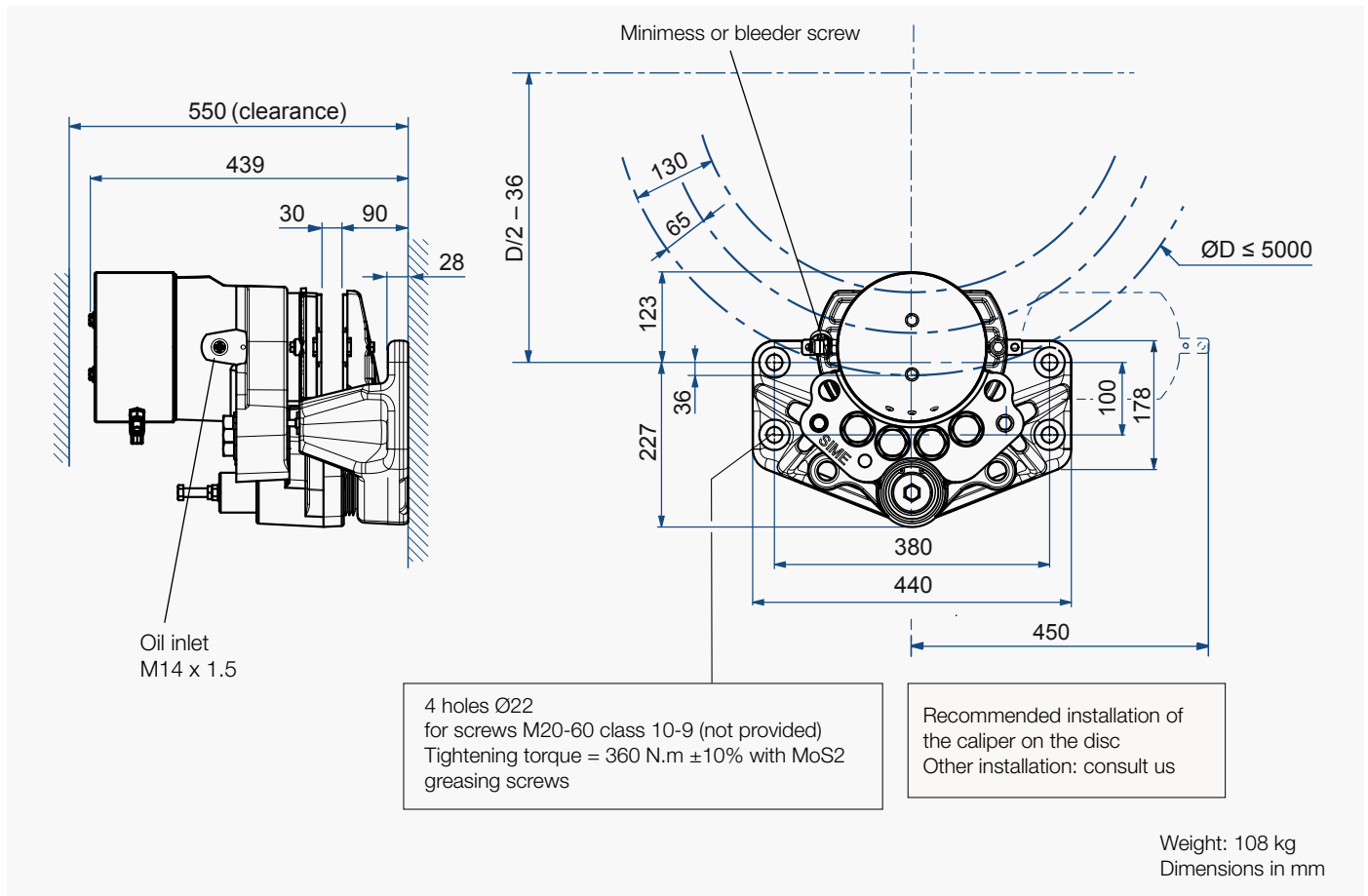

**Electrical data :**

**Opening proximity switch:**  
 3 wires PNP NO  
 10 to 58 VDC 200 mA  
 delivered with connector M12

**Closing and wear switches:** optional



### DISC BRAKE - SHD5A-M2 CALIPER

Revision number: T10131-02-E

Revision date: 27.09.2018



**Installation instructions :**

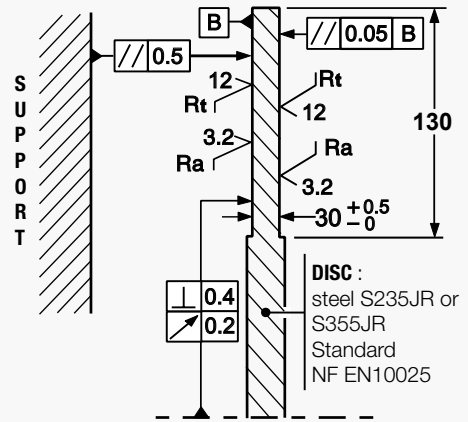

Torque and effort values are subject to a variation of  $\pm 10\%$   
Response time at nominal torque  $\leq 0.3s$

Designation	Caliper SHD5A-...-M2		1	2	3	4	5	6	7	8
	Lining		US2-1							
Braking force BF for 1 mm of air gap disc/lining	Dynamic	N	15500	17700	20000	28000	33000	41000	48000	56000
	Static	N	13650	15600	17600	24650	29050	36100	42250	49300
Linear speed of the disc for BF		m/s	< 10							
Dynamic braking torque BT for a caliper mounted on a disc ØD (mm) Dmax.=1500 mm		N.m	BT = BF (D/2000 - 0.065)							
Regulation pressure	Min.	bar	60	60	85	85	110	140	140	180
	Max.	bar	80	80	115	115	140	160	160	200
Setting pressure limit valve hydraulic pack		bar	105	105	140	140	165	190	190	225
Total volume of oil displaced		cm <sup>3</sup>	12.7 per stroke (for nominal disc/lining stroke of 1 mm per side)							
Max. oil volume of the jack		cm <sup>3</sup>	76							

# SIME Brakes Industrial Braking Systems

## Emergency Brakes

### DISC BRAKE - SHD9 CALIPER

Revision number: T10042-01-E

Revision date: 31.08.2017

Fail safe braking  
 Braking by spring application  
 Hydraulic release  
 Opening proximity switch for PLC  
 (induction sensor)  
 Lining wear detectors  
 Association with discs thickness 30 mm

**Working conditions :**

- Ambient temperature: -10°C to +60°C
  - Relative humidity ≤ 70%
  - Dust in atmosphere ≥ 65µm
- Other conditions, consult us.

**Use :**

- Emergency stopping brake in case of overspeed or loss of electrical supply

**Option :**

- Lining wear proximity switch
- Discs thickness  $24 \leq e < 30$  mm.
- Option GF :  
 Ambient temperature:  
 - Dynamic braking : -30°C to +60°C  
 - Parking braking : -40°C to +60°C
- Marine protection

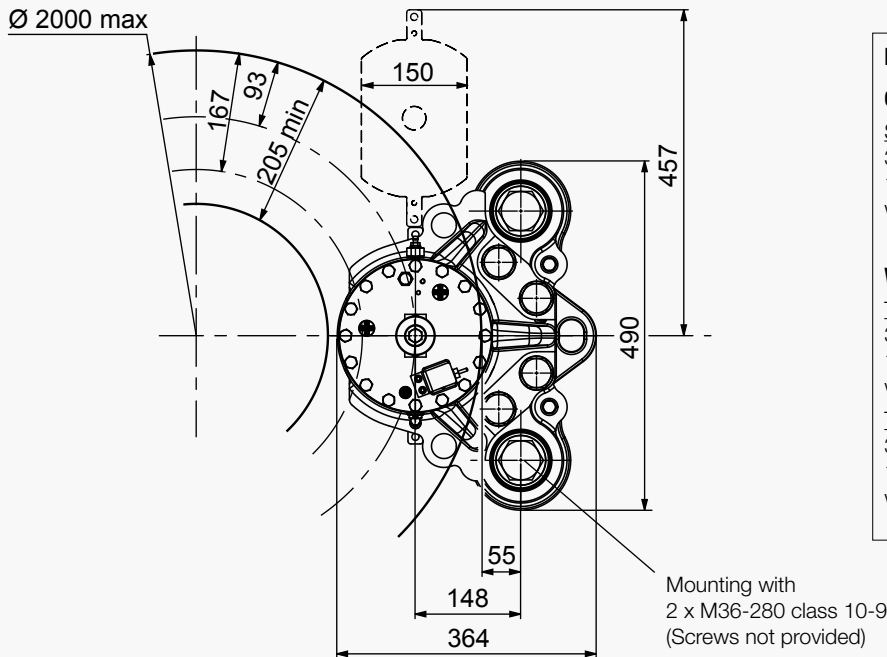

**Electrical data :**

**Opening proximity switch**  
Standard caliper and caliper option GF  
 3 wires PNP NO  
 10 to 58 VDC 200 mA  
 with connector M12

**Wear proximity switch (option):**  
Temperature -10°C to +60°C  
 3 wires PNP NO  
 10 to 58 VDC 200 mA  
 with connector M12  
Temperature -40°C to +60°C / Option GF  
 3 wires PNP NO  
 10 to 36 VDC 200 mA  
 with connector M12

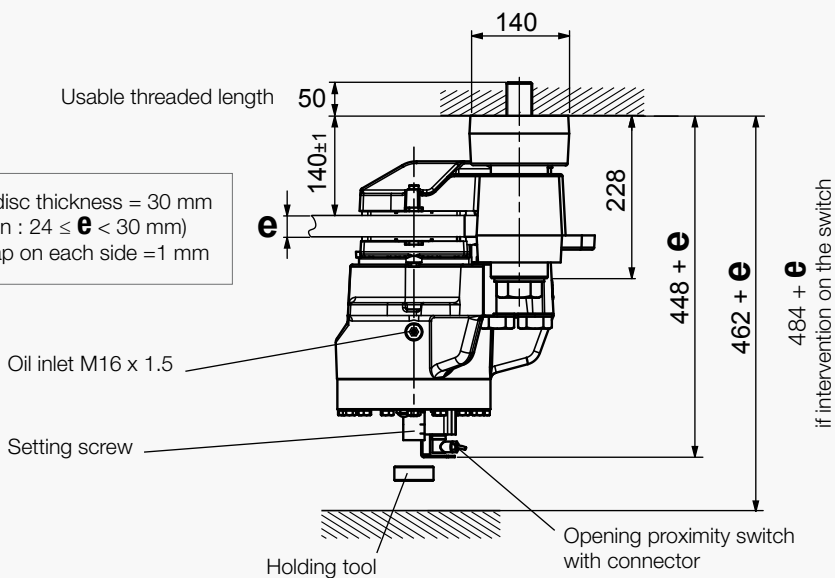

**e** = disc thickness = 30 mm  
 (option :  $24 \leq e < 30$  mm)  
 Air gap on each side = 1 mm

Weight: 148 kg  
 Dimensions in mm

### DISC BRAKE - SHD9 CALIPER

Revision number: T10042-01-E

Revision date: 31.08.2017

#### Installation instructions :

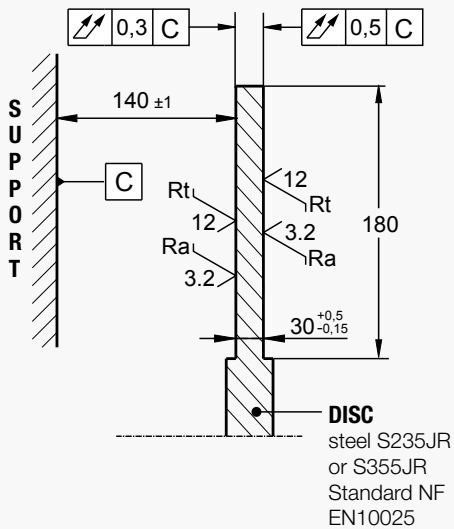

#### Support machining tolerances :

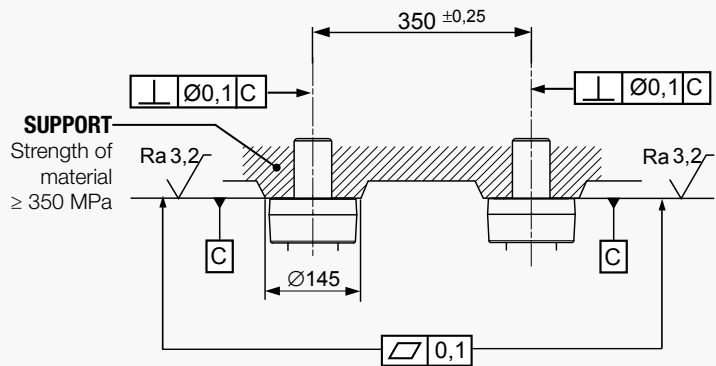

Torque and effort values are subject to a variation of  $\pm 10\%$   
Response time at nominal torque  $\leq 0.3s$

Designation	Caliper		SHD9-6		SHD9-5		SHD9-4		SHD9-3		SHD9-2		SHD9-1	
	Lining *		US2-1	US2-5	US2-1	US2-5	US2-1	US2-5	US2-1	US2-5	US2-1	US2-5	US2-1	US2-5
Braking force BF for air gap disc/lining of 2x1mm	Dynamic	N	100 000	87 000	90 000	78 300	80 000	69 600	70 000	61 000	60 000	52 300	50 000	43 500
	Static	N	88 000	78 300	79 200	70 500	70 400	62 600	61 600	54 900	52 800	47 000	44 000	39 100
Linear speed of the disc		m/s	$\leq 10$											
Dynamic braking torque BT (m.N) for 1 caliper and disc ØD (mm) / D max $\leq 2000$ mm		N.m	BT = BF (D/2000 - 0.093)											
Regulation pressure	Minimum	bar	180		170		150		120		110		90	
	Maximum	bar	200		190		170		140		130		110	
Setting pressure limit valve of hydraulic pack		bar	220		210		190		160		160		130	
Total volume of oil displaced for air gap disc/lining of:		cm <sup>3</sup>												
	2 x 1mm (nominal opening)	cm <sup>3</sup>	28											
2 x 1.5mm (nominal opening and wear before setting)	cm <sup>3</sup>	39												

\* **US2-1**: disc temperature during one braking  $\leq 150^\circ\text{C}$   
**US2-5**: disc temperature during one braking  $\leq 350^\circ\text{C}$ .

# SIME Brakes Industrial Braking Systems

## Emergency Brakes

### DISC BRAKE - SHD18 CALIPER

Revision number: T10129-01-A

Revision date: 13.01.2017

Fail safe braking  
 Braking by spring application  
 Hydraulic release  
 Opening proximity switch for PLC  
 (induction sensor)  
 Full lining wear indicators  
 Association with discs thickness 30 mm  
 Protection level C3 L standard NF ISO9223

**Working conditions :**

- Ambient temperature: -20°C to +60°C
- Relative humidity ≤ 70%
- Dust in atmosphere ≥ 70µm
- Other conditions, consult us.

**Use :**

- Emergency stopping brake in case of overspeed or loss of electrical supply

**Option :**

- Lining wear proximity switch
- Protection level C5-MM standard NF ISO9223

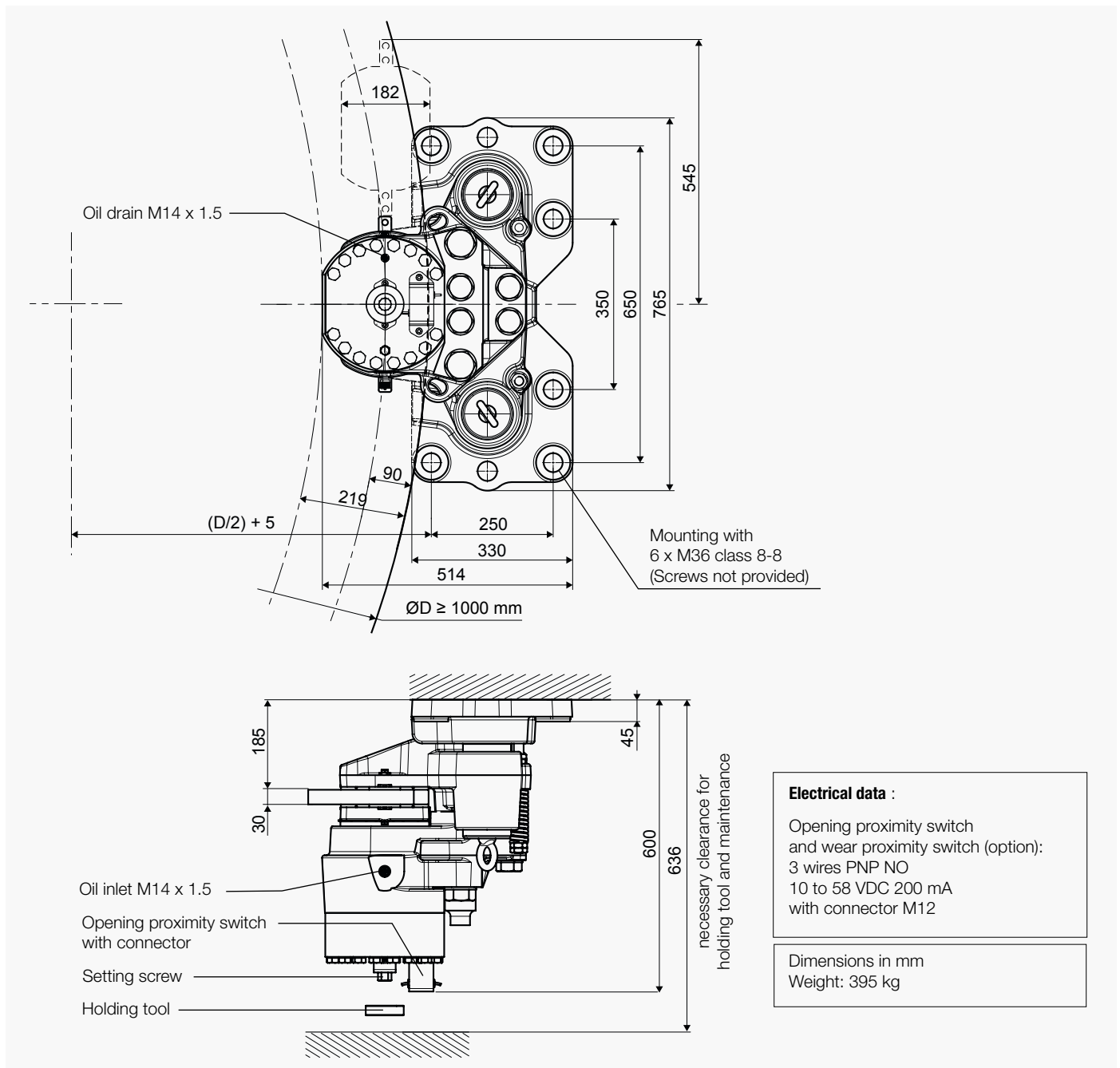

### DISC BRAKE - SHD18 CALIPER

Revision number: T10129-01-A

Revision date: 13.01.2017



#### Installation instructions :

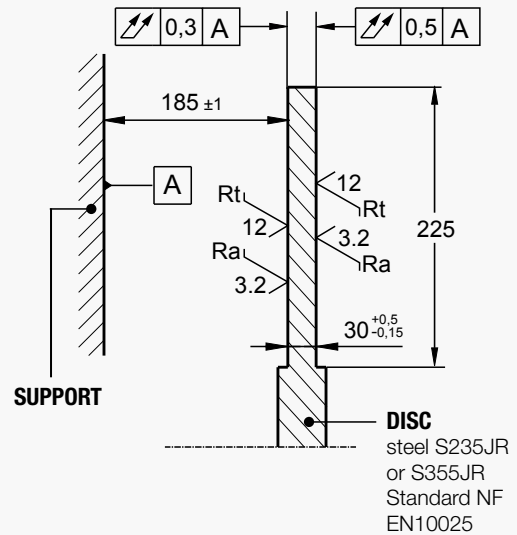

Torque and effort values are subject to a variation of  $\pm 10\%$   
Response time at nominal torque  $\leq 0.3s$

Designation	Caliper		SHD18-3	SHD18-2	SHD18-1
	Lining *		US2-1		
<b>Braking force</b> BF for air gap disc/lining of 2x1mm	Dynamic	N	180 000	150 000	120 000
	Static	N	162 000	135 000	108 000
Linear speed of the disc		m/s	$\leq 10$		
<b>Dynamic braking torque</b> BT (m.N) for 1 caliper and disc $\varnothing D$ (mm) / $D \max \leq 2000mm$		N.m	BT = BF (D/2000 - 0.09)		
Regulation pressure	Minimum	bar	195	160	130
	Maximum	bar	205	170	140
Setting pressure limit valve of hydraulic unit		bar	225	190	160
Total volume of oil displaced for air gap disc/lining of:	2 x 1 mm (nominal opening)	cm <sup>3</sup>	48		
	2 x 2 mm (nominal opening + wear before setting)	cm <sup>3</sup>	82		

\* **US2-1**: disc temperature during one braking  $\leq 150^\circ C$

# SIME Brakes Industrial Braking Systems

## Emergency Brakes

### DISC BRAKE - TH9 CALIPER

Revision number: T03830-01-C

Revision date: 13.12.2010

Fail safe  
Spring applied  
Hydraulic release (mineral oil)  
Opening proving switch  
Wear proving switch  
Lining wear detector

**Working:**

- Ambient temperature: -10°C to +60°C
- Relative humidity ≤ 70%
- Dust in atmosphere ≥ 65µ

Other conditions, consult us.

**Use:**

Service brake to operate with full or variable torque  
Emergency brake in case of overspeed or loss of electrical supply

**Option:**  
Disc thickness 42 mm

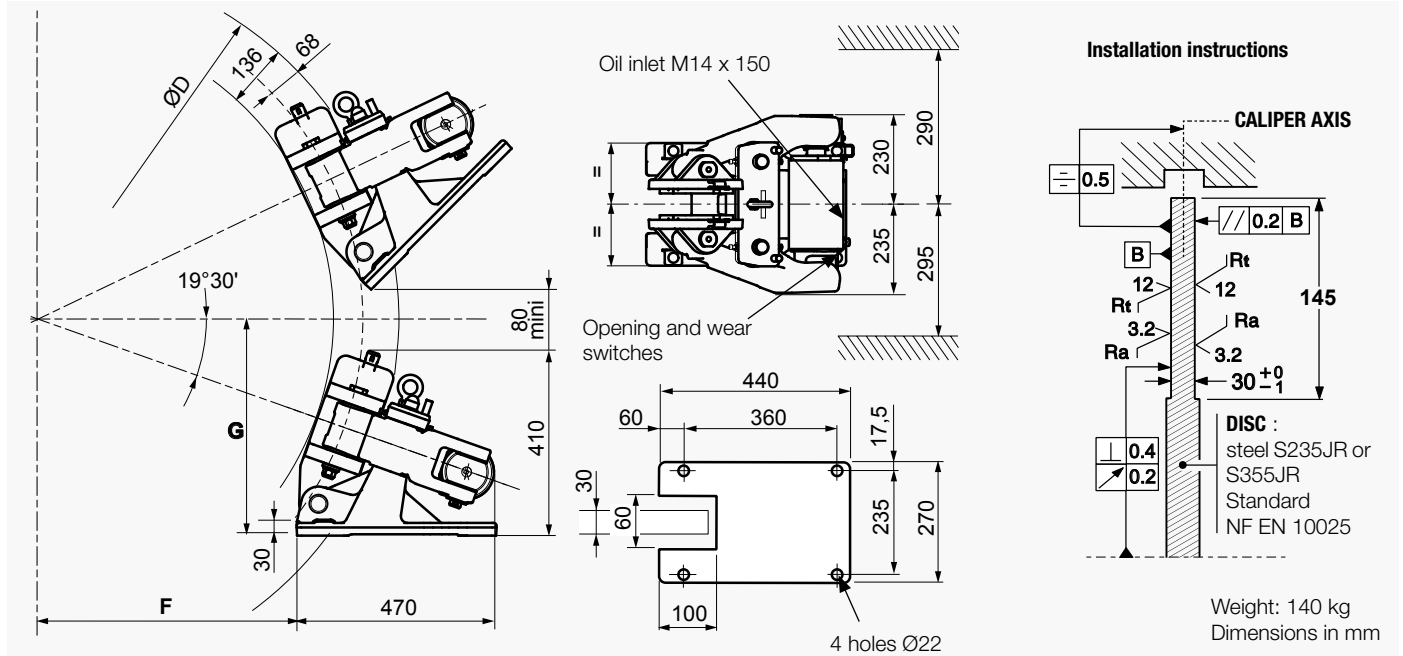

Designation	Caliper		TH9-3		TH9-2		TH9-1	
	Lining *		US2-1	WS1-3	US2-1	WS1-3	US2-1	WS1-3
Braking force BF for 1mm of air gap disc/lining	Static	N	81 000	54 000	52 650	38970	28 350	22 140
	Dynamic	N	90 000	60 000	58 500	43 300	31 500	24 600
Linear speed of the disc		m/s	≤10	≤50	≤10	≤50	≤10	≤50
Dynamic braking torque BT (N.m) for 1 caliper and a disc ØD (mm)	1000 mm	Nm	38 880	25 920	25 270	18 700	13 600	10 620
	1200 mm	Nm	47 880	31 920	31 120	23 030	16 750	13 080
	1500 mm	Nm	61 380	40 920	39 890	29 530	21 480	16 770
	2000 mm	Nm	83 880	55 920	54 520	40 350	29 350	22 920
BT for other ØD (mm)		Nm	BT = BF (D/2000 - 0.068)					
Positioning when D < 3000mm Above it, consult us	F	mm	(0.4713 x D) - 172					
	G	mm	(0.1669 x D) + 212					
Regulation pressure	minimum	bar	140		85		60	
	maximum	bar	160		115		80	
Setting pressure limit valve of hydr. unit		bar	190		140		105	
Total volume of oil displaced		cm³	58 for one stroke disc/lining (nominal wear and opening)					

Torque and force values are subject to a variation of ±10%.

Response time at nominal torque : see leaflet n° G08555-01.

**Opening and wear switches :**

250VAC maxi., 5A maxi., with interrupting capacity: 50VA maxi.

220VDC maxi., 5A maxi., with interrupting capacity: 50W maxi.

Compatible with PLC (Programmable Logic Controllers).  
A switch used with other equipment than PLC must not be reused with a PLC.

Opening and wear switches are delivered with wire 5 x 0.75mm² and length 1m each

\* **US2-1:** disc temperature during one braking ≤ 150°C  
**WS1-3:** disc temperature during one braking ≤ 600°C  
**US2-5:** disc temperature during one braking ≤ 350°C, optional, consult us.



### DISC BRAKE - THC9B CALIPER

Revision number: T03836-01-C

Revision date: 24.08.2012

Fail safe  
Spring application  
Hydraulic release  
Integral hydraulic power unit  
Self contained electric system  
Opening proving switch  
Lining wear control switch  
Lining wear detector

**Operating conditions:**

- Ambient temperature: -10°C to +60°C
- Relative humidity: ≤ 70%
- Dust in atmosphere ≥ 65µ

Other conditions, please contact us.

**Use:**

The brake should be applied only in case of emergency stop, overspeed or shutdown of electric mains. Other use, please contact us.

**Options:**

- Progressive braking system
- Disc thickness 42 mm

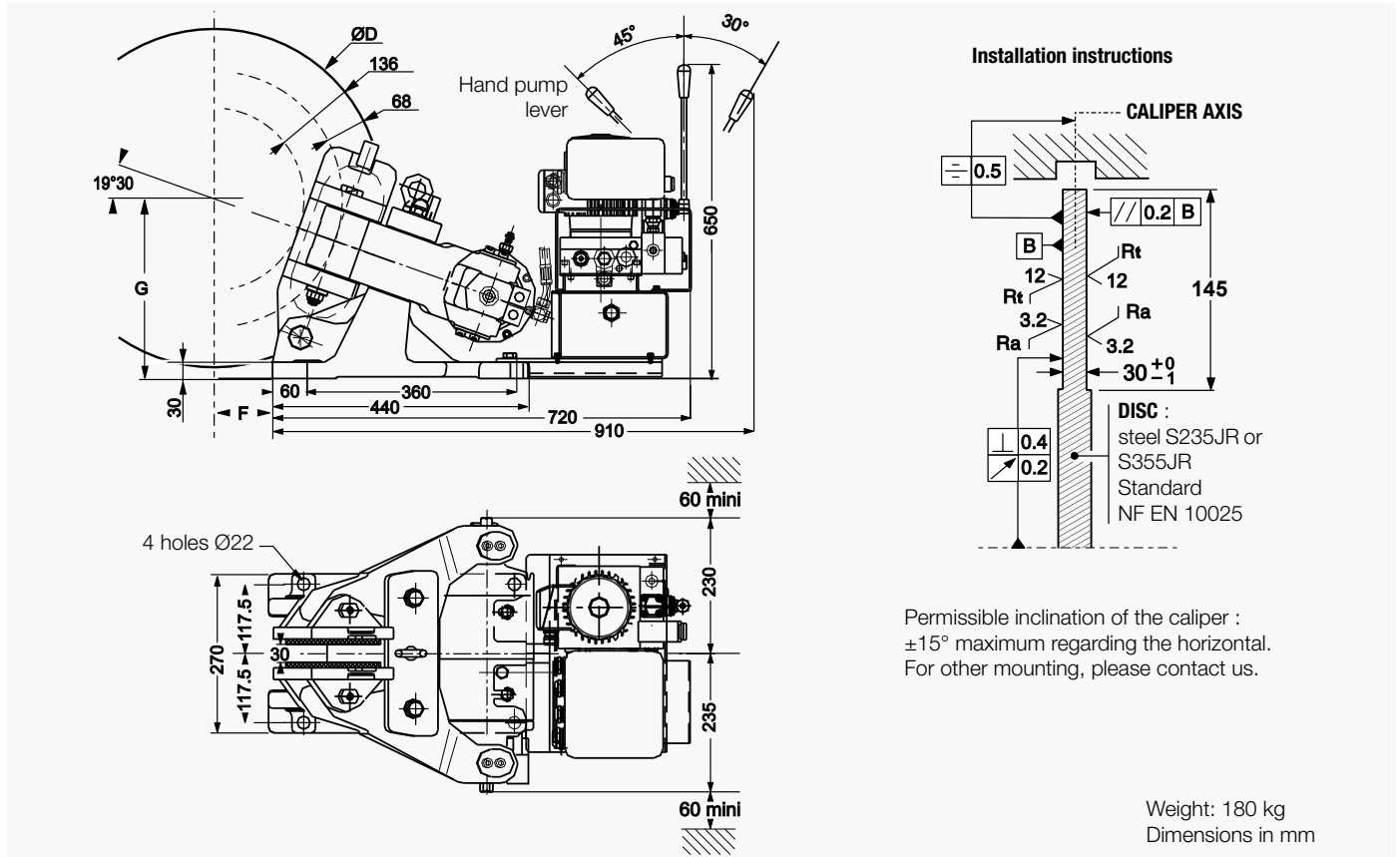

Designation	Caliper		TH9-3		TH9-2		TH9-1		
	Lining *		US2-1	WS1-3	US2-1	WS1-3	US2-1	WS1-3	
Braking force BF for 1mm of air gap disc/lining	Static	N	81 000	54 000	52 650	38 970	28 350	22 140	
	Dynamic	N	90 000	60 000	58 500	43 300	31 500	24 600	
Linear speed of the disc		m/s	≤10	≤50	≤10	≤50	≤10	≤50	
Dynamic braking torque BT (N.m) for 1 caliper and a disc ØD (mm)	1000 mm	Nm	38 880	25 920	25 270	18 700	13 600	10 620	
	1200 mm	Nm	47 880	31 920	31 120	23 030	16 750	13 080	
	1500 mm	Nm	61 380	40 920	39 890	29 530	21 480	16 770	
	2000 mm	Nm	83 880	55 920	54 520	40 350	29 350	22 920	
BT for other ØD (mm)		Nm	BT = BF (D/2000 - 0.068)						
Positioning when D<3000mm Above it, consult us	F	mm	(0.4713 x D) - 172						
	G	mm	(0.1669 x D) + 212						
Setting pressure limit valve of hydr. pack		bar	190		140		105		

\* **US2-1:** disc temperature during one braking ≤ 150°C  
**WS1-3:** disc temperature during one braking ≤ 600°C  
**US2-5:** disc temperature during one braking ≤ 350°C, optional, consult us.

**Electrical data:**

HPP motor: 3 phases: 230/400V ±10%  
50Hz 0.37kW, 4 poles  
for mains: 230/400 V 50 Hz  
or 415 V 50 Hz or 460 V 60 Hz

Motor option: 400/690V ±10% 50Hz  
255/440V ±10% 50Hz  
290/500V ±10% 50Hz  
280/480V ±10% 60Hz  
330/575V ±10% 60Hz

Other voltage, please contact us.  
Electrical casing IP55

Opening and wear proving switches:  
U mini 24V AC or DC  
U maxi 250V AC ou 220 V DC  
I mini 0.1A AC or DC  
I maxi 5A AC or DC  
interrupting capacity :  
mini : 2.4VA AC or 2.4W DC  
maxi : 50VA (AC) ou 50W (DC)

# SIME Brakes Industrial Braking Systems

## Electrical Power Units

# ELECTRICAL POWER UNITS

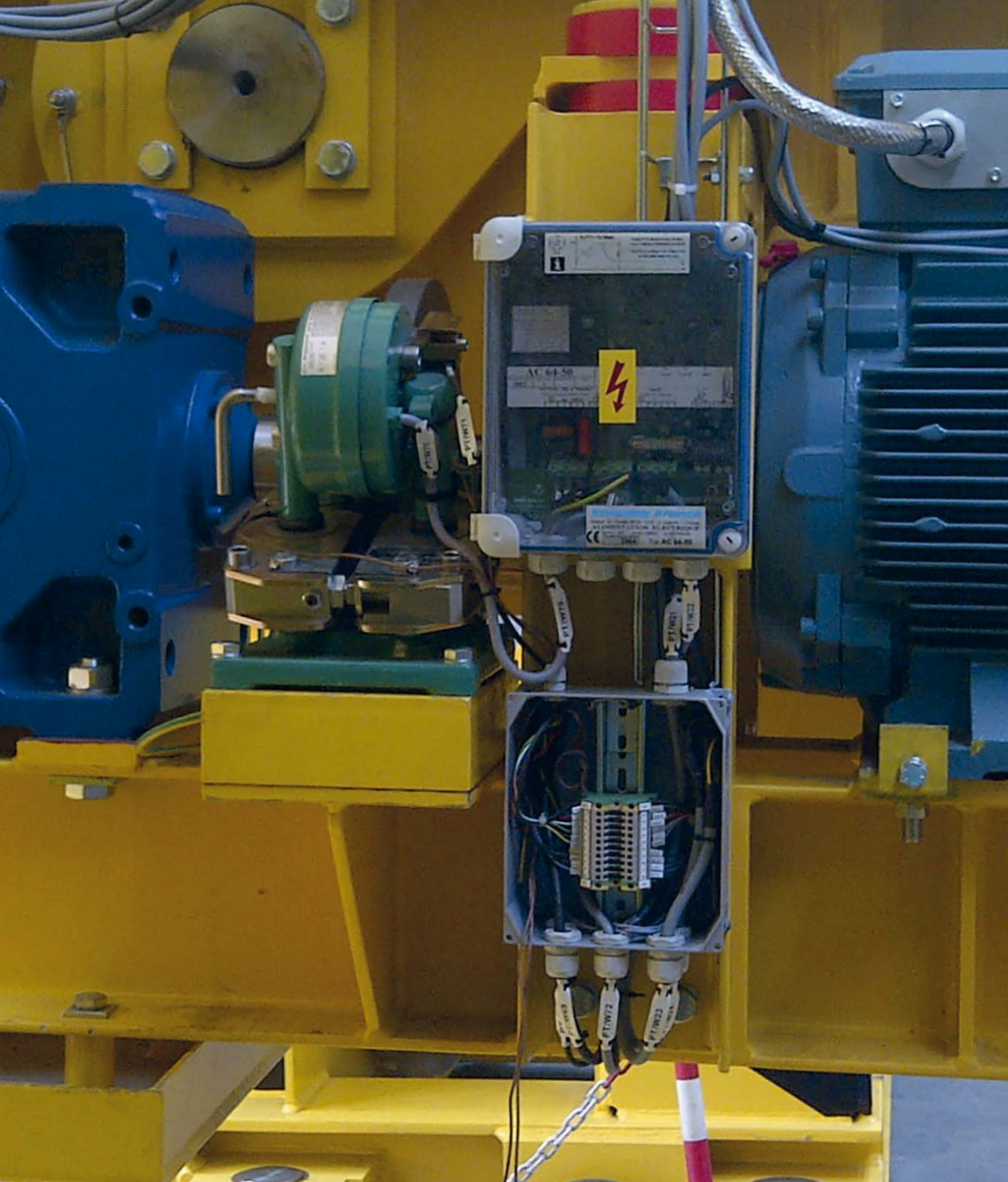

# SIME Brakes Industrial Braking Systems

## Electrical Power Units

### MAIN CHARACTERISTICS

- DESIGNED TO GIVE OPTIMUM PERFORMANCE FROM THE ELECTROMAGNETIC CALIPERS
- AC LINE SUPPLY: AB8, AC64, AC32, AS100, 4200 AND 4205
- DC LINE SUPPLY: DC64, DC32 AND DS100
- HIGH "CALL" VOLTAGE TO REDUCE OPENING RESPONSE TIME
- AUTOMATIC REDUCTION TO AN ECONOMICAL "HOLD" VOLTAGE
- A "CUT-OUT" CIRCUIT GIVING A VERY SHORT BRAKE ACTION



#### AC64 & AC32

- Simplicity of adjustment and use.
- Weights and size reduced.
- Quick diagnosis of fault through the use of 6 LEDs.
- Standard mains: 230/500 VAC, 115/220 VDC

#### AS100

- Other mains: 115 VAC, 500/700 VAC, 24 VDC et 48 VDC
- Available in:
  - Polycarbonate enclosure (CP): IP66, IK8
  - or Steel enclosure (CA): IP66, IK9

#### 4200 & 4205 / AB8

- **4205** unit enables electrically controlled lowering.
- **AB8** unit is used with "E" series calipers for progressive braking torque control.

POWER UNITS	CALIPERS											
	660	650	650E	645 - 45K	5D - 5DR	5DE	4CA2	3CA2	2CA2 - 1CA2	OSA	OOSA	2SA
AC64 - DC64												
AC32 - DC32												
AS100 - DS100												
4200												
4205												
AB8												

# SIME Brakes Industrial Braking Systems

## Electrical Power Units

### DISC BRAKE - ELECTRICAL POWER UNIT AC64-50 CA

Revision number: T04560-01-D

Revision date: 20.07.2011

Compact power supply operating on alternating single or two-phase mains.  
For SIME Disc Brakes with 50 V coil.  
type : 660/650-5K/5D-645-45K-4WD-4CA2  
Steel case

**Operating Conditions:**

- Casing protection standard IP66 IK09
- Ambient temperature : -20°C to +60°C

**Electrical Data :**

Single or two-phase mains AC  
230 to 500V AC ± 10% 50/60Hz

**EC marking of conformity :**

- 2006/95/EC directive BT (standard EN60204-1)  
- 2004/108/EC directive CEM  
(standards EN61000-6-2 EN61000-6-4)

**Options:**

- Closure delay of the caliper
- Disengageable closure delay of the caliper (cannot be combined with anti-condensation)
- Anti-condensation kit
- Polycarbonate case IP66 IK08

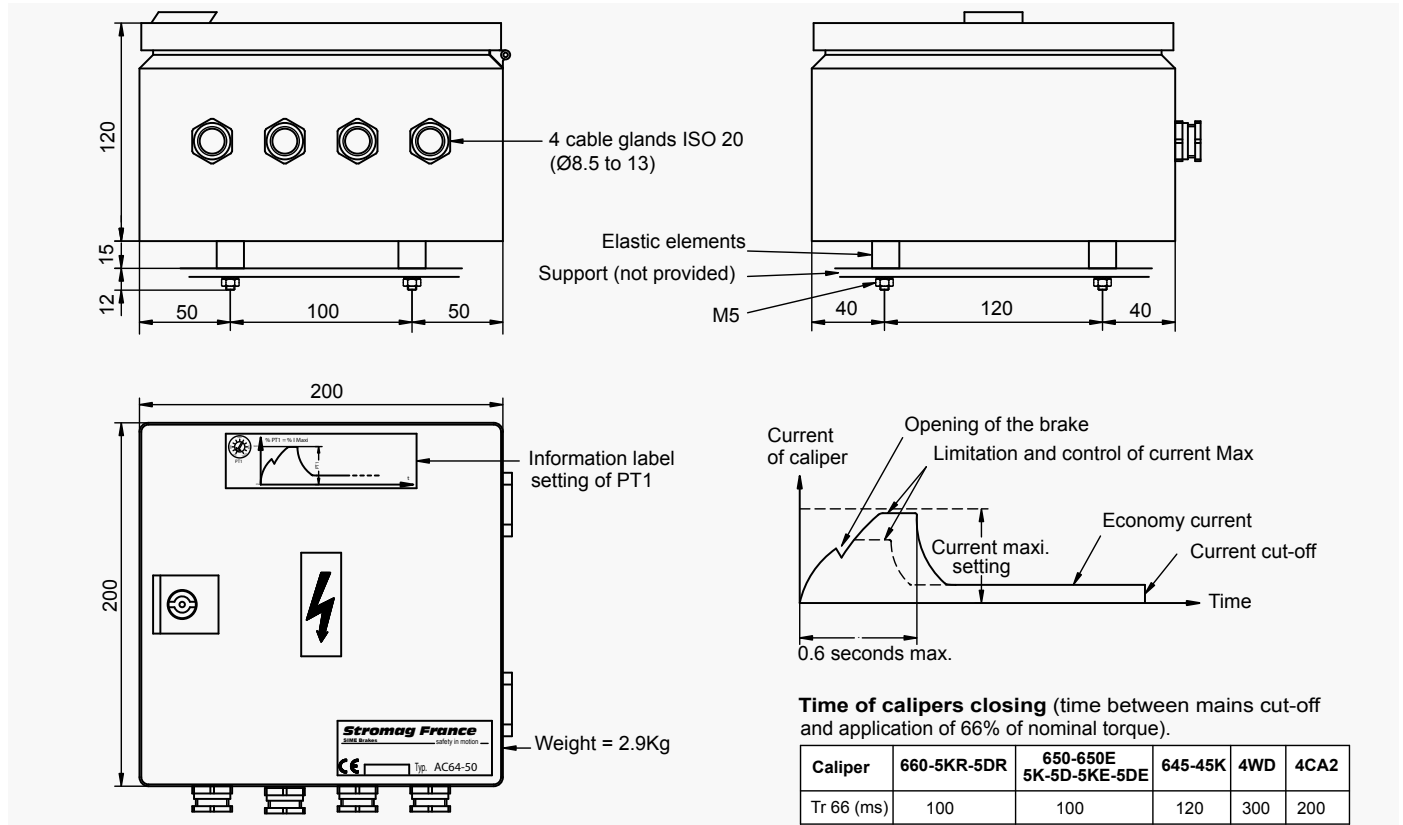

**Time of calipers closing** (time between mains cut-off and application of 66% of nominal torque).

Caliper	660-5KR-5DR	650-650E 5K-5D-5KE-5DE	645-45K	4WD	4CA2
Tr 66 (ms)	100	100	120	300	200

Caliper		660-650-650E	5K-5D-5KR/DR 5KE-5DE	645	45K	4WD	4CA2
Maximum number of calipers		2	2	2	2	2	1
Resistance at 20°C per caliper		Ω 6.68	6.68	4.52	4.52	4.52	3.08
Maximum number of actuations per hour and ambient temperature θ	θ ≤ 40°C	150	1000	150	1000	60	1000
	40°C < θ ≤ 60°C	150	600	150	600	60	600
Mains current absorbed per caliper	Max	A 4	4	6	6	6	9
	Economy	A 0.6	0.6	0.75	0.75	0.75	1
Maximum return resistance of the cable connecting the caliper to the power supply		Ω 2	2	1	1	1	1 *
Max. length of the connecting cable (Power supply - caliper) for 1 caliper per cable. depending on cable section	2.5 mm <sup>2</sup>	m 100	100	50	50	50	50 *
	4 mm <sup>2</sup>	m 160	160	80	80	80	80 *
	6 mm <sup>2</sup>	m 240	240	120	120	120	120 *
Protection to be provided in head of control contactor on mains input	Number of caliper	1   2	1   2	1   2	1   2	1   2	1
	Fuse aM	A 1   2	1   2	2   4	2   4	2   4	4
	Circuit-breaker curve C	A 1   2	1   2	2   4	2   4	2   4	4

### DISC BRAKE - ELECTRICAL POWER UNIT AC64-50 CP

Revision number: T04500-01-D

Revision date: 19.07.2011

Compact power supply operating on alternating single or two-phase mains.  
For S Disc Brakes with 50 V coil.  
type : 660/650-5K/5D-645-45K-4WD-4CA2  
Polycarbonate case

**Operating Conditions:**

- Casing protection standard IP66 IK08
- Ambient temperature : -20°C to +60°C

**Electrical Data :**

Single or two-phase mains AC  
230 to 500V AC  $\pm$  10% 50/60Hz

**EC marking of conformity :**

2006/95/EC directive BT (standard EN60204-1)  
2004/108/EC directive CEM  
(standards EN61000-6-2 EN61000-6-4)

**Options:**

- Closure delay of the caliper
- Disengageable closure delay of the caliper (cannot be combined with anti-condensation)
- Anti-condensation kit
- Steel case IP66 IK09

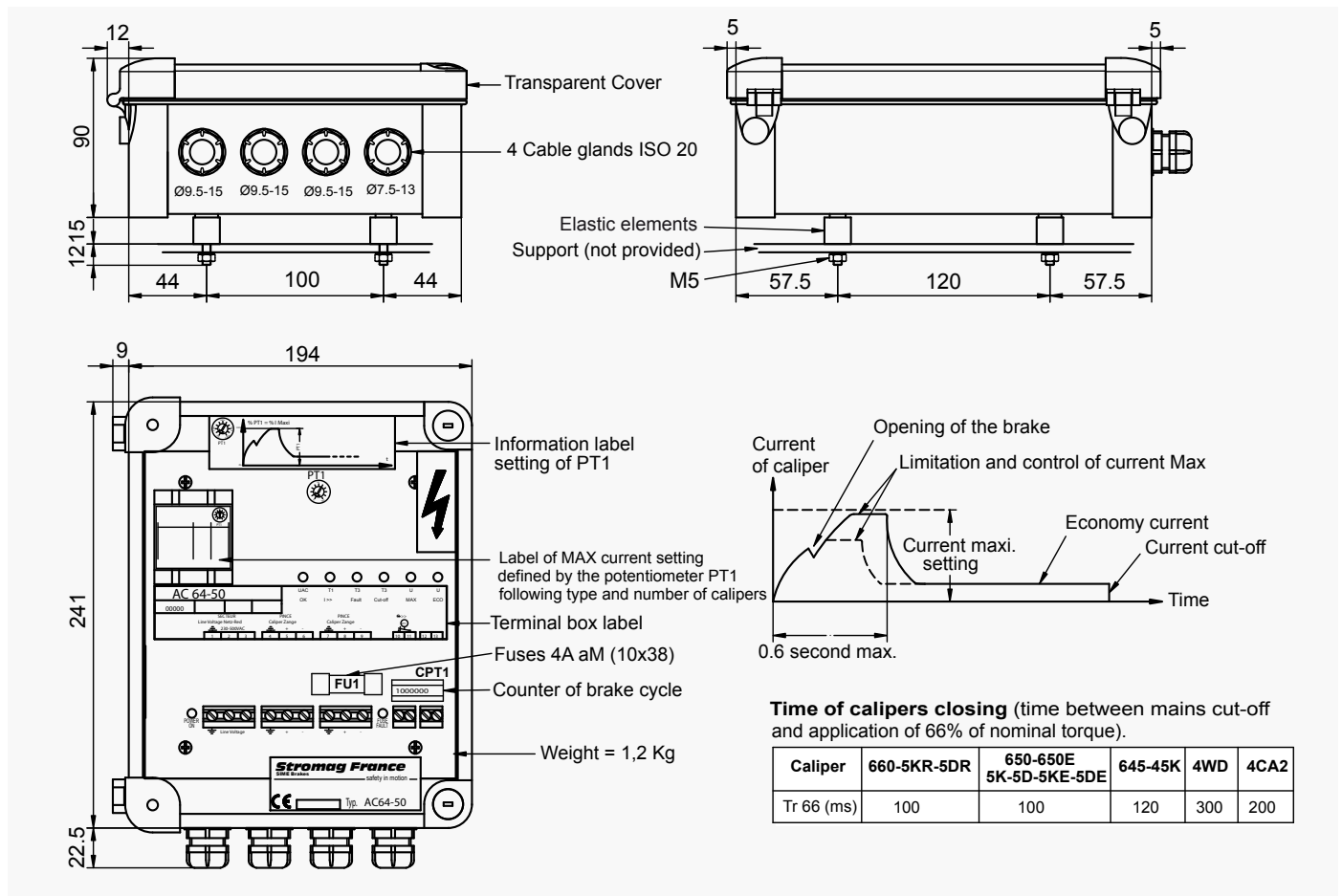

**ELECTRICAL DANGER : THIS PRODUCT IS NOT INSULATED**

Control and power electronic of power supply is not insulated and is under mains voltage. The power supply must be installed by qualified personnel, used to handle this equipment type and aware of risks inherent in their utilization.

\* If the ambient temperature of the caliper 4CA2 is higher than 60°C, the maximum return resistance and the maximum length of the connecting cable given in the above table must be divided by 2.

**Time of calipers closing** (time between mains cut-off and application of 66% of nominal torque).

Caliper	660-5KR-5DR	650-650E 5K-5D-5KE-5DE	645-45K	4WD	4CA2
Tr 66 (ms)	100	100	120	300	200

# SIME Brakes Industrial Braking Systems

## Electrical Power Units

### DISC BRAKE - ELECTRICAL POWER UNIT AC32-50 CA

Revision number: T10005-02-C

Revision date: 22.02.17

Compact power supply operating on alternating single or two-phase mains.  
For SIME disc brakes with 50 V coil.  
type : 4CA2 - 3WD - 3CA2 - 2CA2 - 1CA2  
Steel case

**Operating Conditions:**

- Casing protection standard IP66 IK10
- Ambient temperature : -20°C to +60°C

**Electrical Data :**

Single or two-phase mains AC  
230 to 500V AC  $\pm$  10% 50/60Hz

**EC marking of conformity :**

- 2006/95/CE directive Low Voltage (standard EN60204-1)
- 2004/108/CE directive EMC (standards EN61000-6-2 and EN61000-6-4)

**Options:**

- Closure delay of the caliper
- Disengageable closure delay of the caliper (cannot be combined with anti-condensation)
- Anti-condensation kit
- Polycarbonate case IP66 IK08

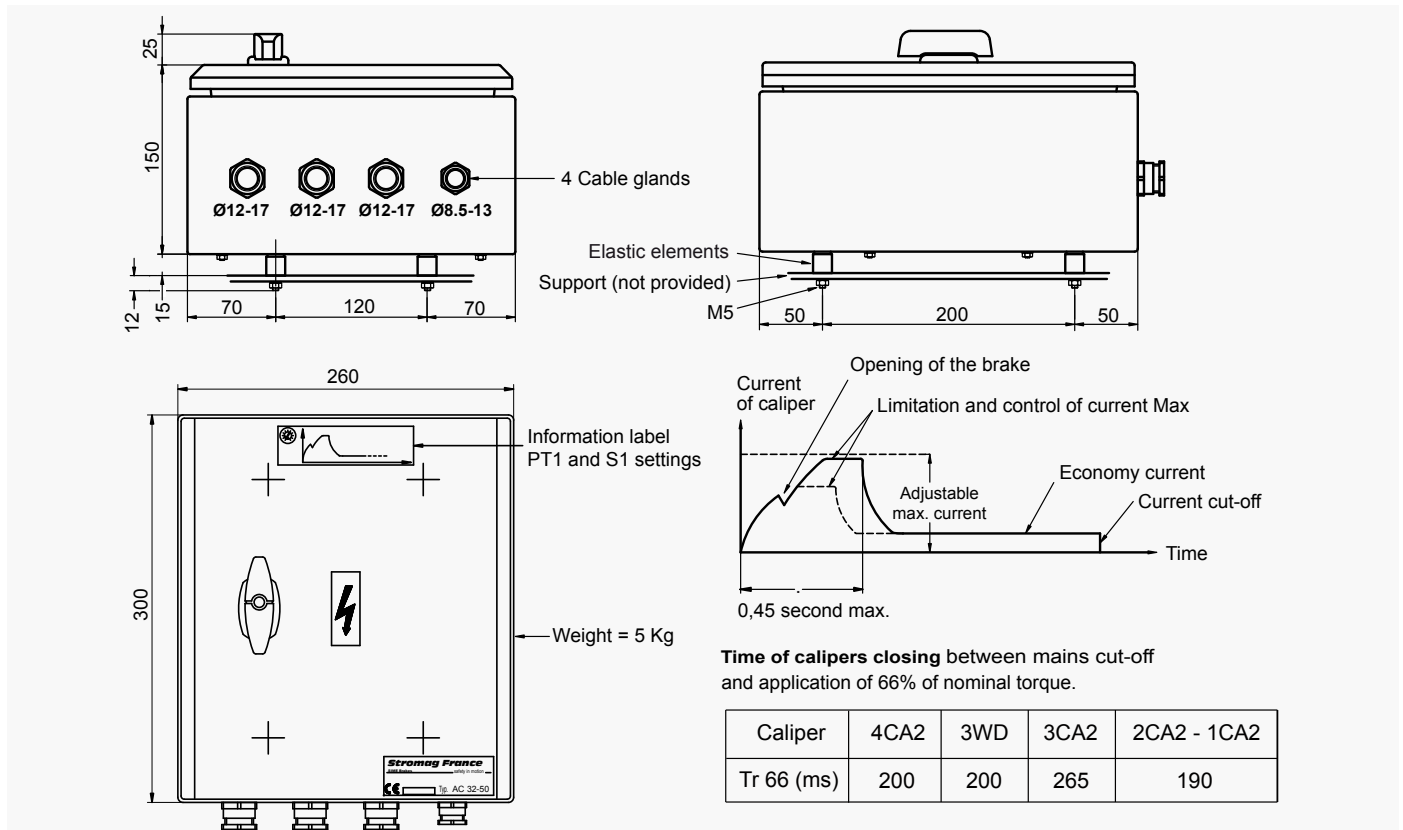

Time of calipers closing between mains cut-off and application of 66% of nominal torque.

Caliper	4CA2	3WD	3CA2	2CA2 - 1CA2
Tr 66 (ms)	200	200	265	190

Caliper		4CA2	3WD	3CA2	2CA2 1CA2	2CA2 + 20% 1CA2 + 20%
Maximum number of calipers		2	1	1	1	
Resistance at 20°C per caliper	$\Omega$	3.08	1.63	1.01	0.75	
Maximum number of actuations per hour and ambient temperature $\theta$	$\theta \leq 40^\circ\text{C}$	1000	60	1000	1000	600
	$40^\circ\text{C} < \theta \leq 60^\circ\text{C}$	600	60	600	600	300
Mains current absorbed per caliper	Max	A	9	16	28.2	
	Economy	A	1	1.5	3.3	
Maximum connecting cable return resistance between caliper and supply unit	$\Omega$	1	0.75	1	0.5	
Maximum connecting cable length (caliper-input) according to the cable section	2.5mm <sup>2</sup>	m	50	35	50	25
	4mm <sup>2</sup>	m	80	60	80	40
	6mm <sup>2</sup>	m	120	90	120	60
	10mm <sup>2</sup>	m	205	155	205	100
Protection to be provided in head of control contactor on mains input	Fuse aM	A	6	4	6	8
	Circuit-breaker curve C	A	8	6	10	12

### DISC BRAKE - ELECTRICAL POWER UNIT AC32-50 CP

Revision number: T10005-01-E

Revision date: 04.04.2018

Compact power supply operating on alternating single or two-phase mains.  
For SIME disc brakes with 50 V coil.  
type : 4CA2 - 3WD - 3CA2 - 2CA2 - 1CA2  
Polycarbonate case

**Operating Conditions:**

- Casing protection standard IP66 IK08
- Ambient temperature : -20°C to +60°C

**Electrical Data :**

Single or two-phase mains AC  
230 to 500V AC  $\pm$  10% 50/60Hz

**EC marking of conformity :**

- 2006/95/CE directive Low Voltage (standard EN60204-1)
- 2004/108/CE directive EMC (standards EN61000-6-2 and EN61000-6-4)

**Options:**

- Closure delay of the caliper
- Disengageable closure delay of the caliper (cannot be combined with anti-condensation)
- Anti-condensation kit
- Steel case IP66 IK10

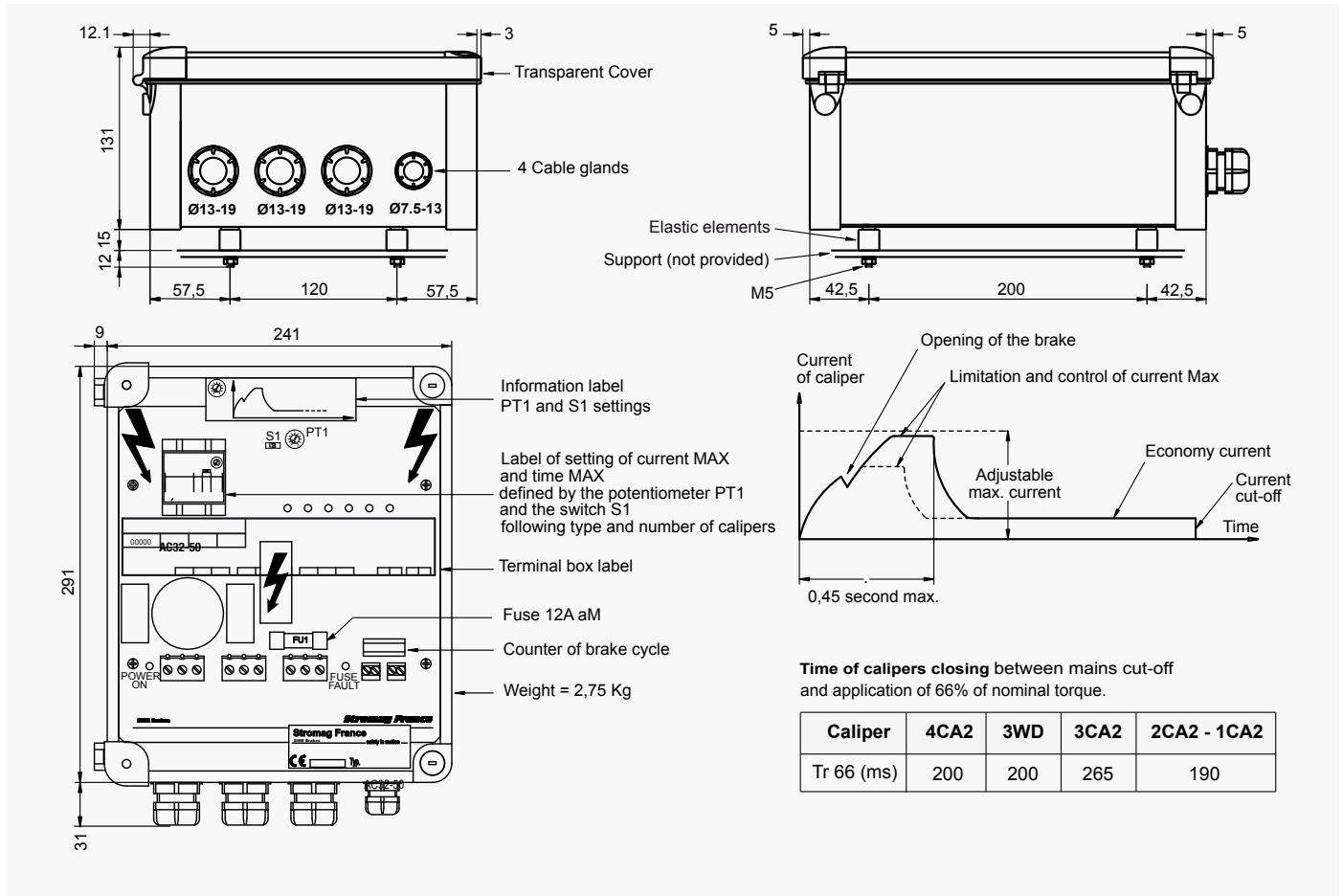

**Time of calipers closing** between mains cut-off and application of 66% of nominal torque.

Caliper	4CA2	3WD	3CA2	2CA2 - 1CA2
Tr 66 (ms)	200	200	265	190

**ELECTRICAL DANGER : THIS PRODUCT IS NOT INSULATED**

Control and power electronic of power supply is not insulated and is under mains voltage. The power supply must be installed by qualified personnel, used to handle this equipment type and aware of risks inherent in their utilization.

# SIME Brakes Industrial Braking Systems

## Electrical Power Units

### DISC BRAKE - ELECTRICAL POWER UNIT AS100-50 CA

Revision number: T10035-02-B

Revision date: 19.10.2015

Compact power supply operating on alternating single or two-phase mains.  
For SIME disc brakes with 50 V coil.  
type : OSA - OOSA  
Steel case

**Electrical Data :**  
Single or two-phase mains AC  
230 to 500V AC  $\pm$  10% 50/60Hz

- Options:**
- Closure delay of the caliper
  - Disengageable closure delay of the caliper (cannot be combined with anti-condensation)
  - Anti-condensation kit
  - Steel case IP66 IK08

**Operating Conditions:**

- Casing protection standard IP66 IK10
- Ambient temperature : -20°C to +60°C

**EC marking of conformity :**

- 2006/95/CE directive Low Voltage (standard EN60204-1)
- 2004/108/CE directive EMC (standards EN61000-6-2 and EN61000-6-4)

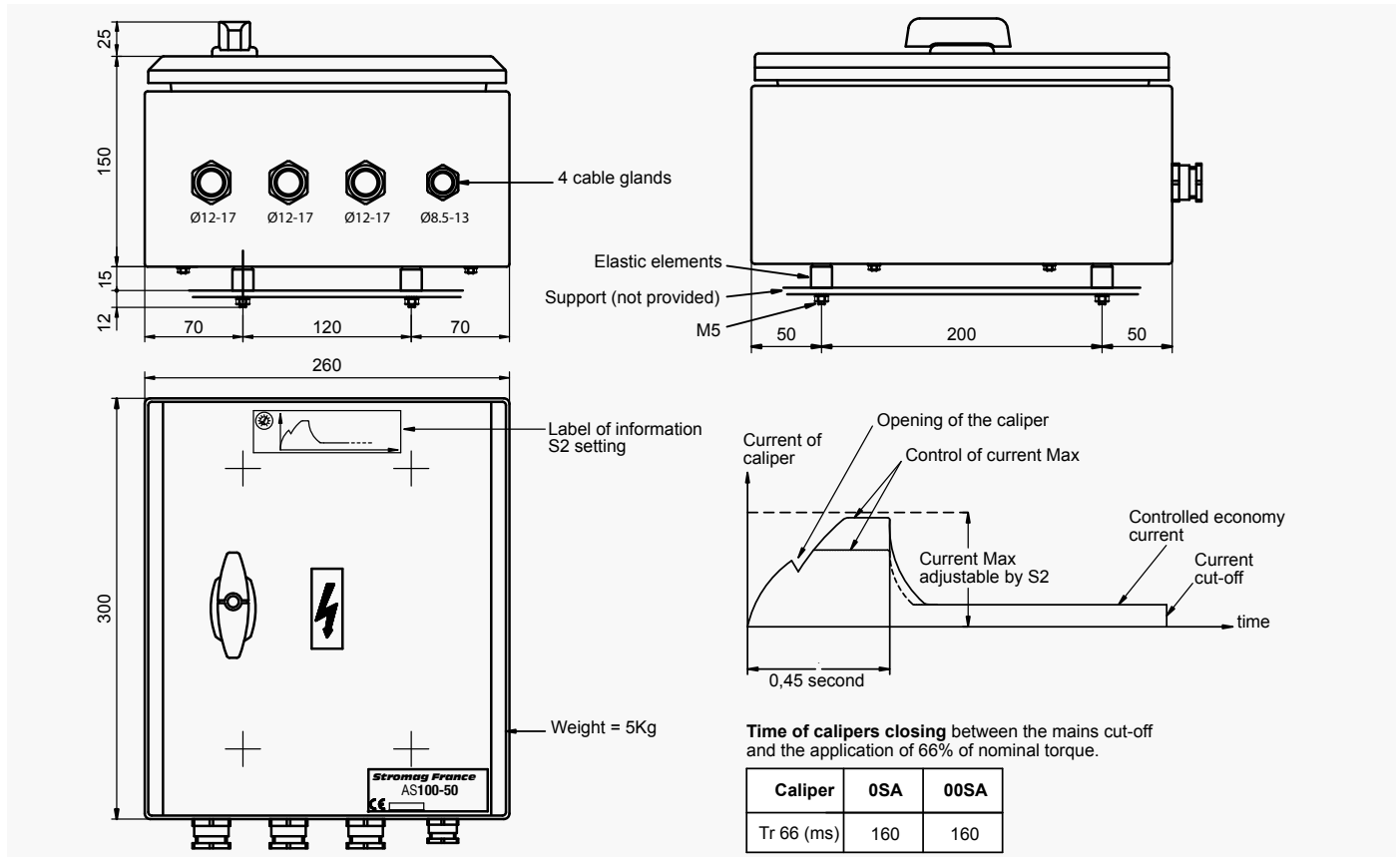

Caliper		OSA			OOSA
Maximum number of calipers			1	2	1
Resistance at 20°C per electromagnet		Ω	1.01	1.01	1.01
Maximum number of actuations per hour and ambient temperature θ	θ ≤ 60°C		100	100	100
	Max	A	28	36	36
Mains current absorbed	Economy	A	3.5	3.6	3.6
	Maximum connecting cable return resistance between caliper and supply unit	Ω	3.5	1	1
Maximum connecting cable length (caliper input) according to the cable section	2.5 mm <sup>2</sup>	m	170	50	50
	4 mm <sup>2</sup>	m	275	80	80
	6 mm <sup>2</sup>	m	415	120	120
	10 mm <sup>2</sup>	m	715	205	205
Protection to be provided in head of control contactor on mains input	Fuse aM	A	6	8	8
	Circuit-breaker curve C	A	16	16	16



### DISC BRAKE - ELECTRICAL POWER UNIT AS100-50 CP

Revision number: T10035-01-B

Revision date: 19.10.2015

Compact power supply operating on alternating single or two-phase mains.  
For SIME disc brakes with 50 V coil.  
type : OSA - OOSA  
Polycarbonate case

**Electrical Data :**  
Single or two-phase mains AC  
230 to 500V AC  $\pm$  10% 50/60Hz

**Options:**

- Closure delay of the caliper
- Disengageable closure delay of the caliper (cannot be combined with anti-condensation)
- Anti-condensation kit
- Steel case IP66 IK10

**Operating Conditions:**

- Casing protection standard IP66 IK08
- Ambient temperature : -20°C to +60°C

**EC marking of conformity :**

- 2006/95/CE directive Low Voltage (standard EN60204-1)
- 2004/108/CE directive EMC (standards EN61000-6-2 and EN61000-6-4)

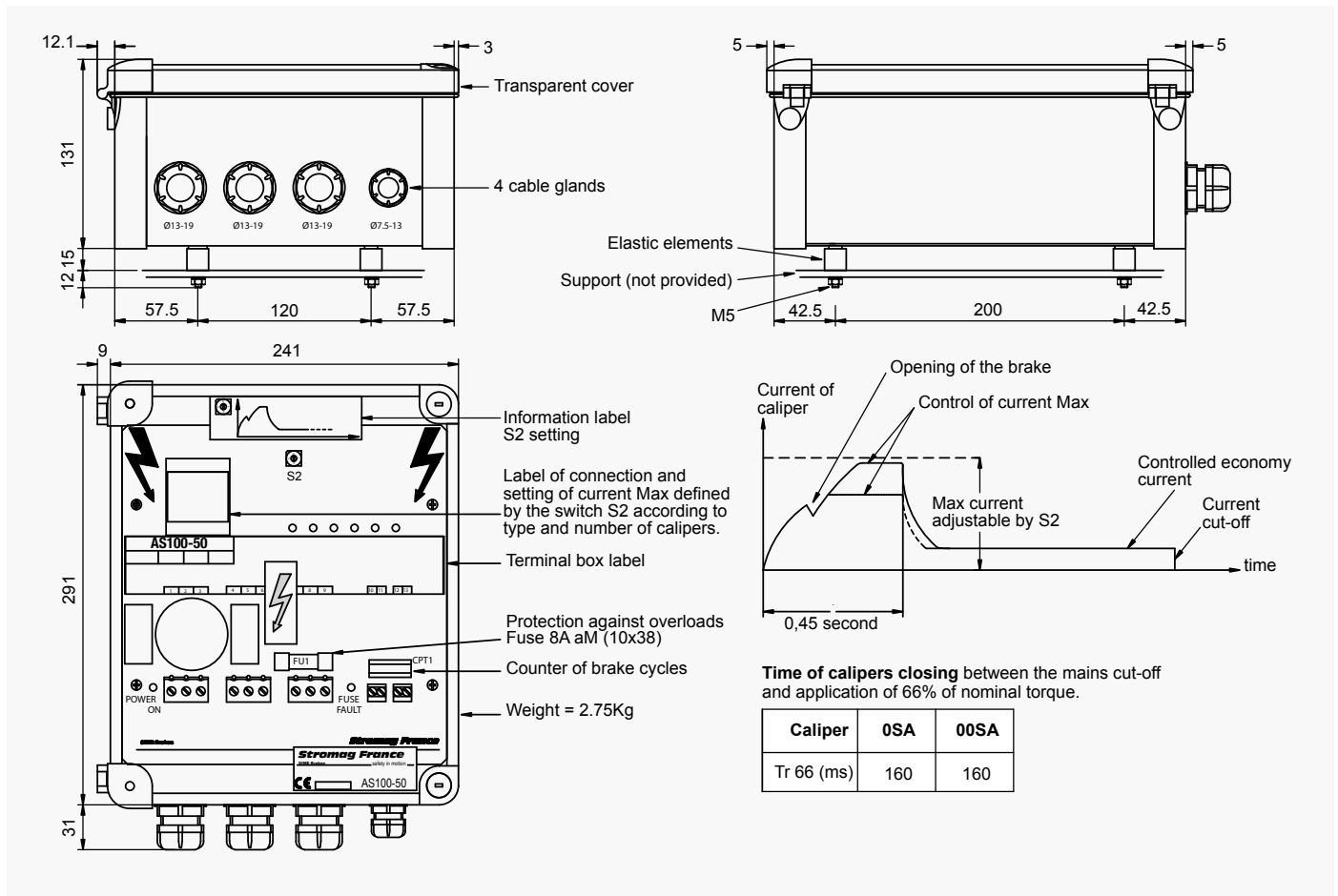

**ELECTRICAL DANGER : THIS PRODUCT IS NOT INSULATED**

Control and power electronic of power supply is not insulated and is under mains voltage. The power supply must be installed by qualified personnel, used to handle this equipment type and aware of risks inherent in their utilization.

# SIME Brakes Industrial Braking Systems

## Electrical Power Units

### DISC BRAKE - ELECTRICAL POWER UNIT DC64-50 CP

Revision number: T04530-01-F

Revision date: 25.02.2019

Compact power supply operating on direct mains.  
For SIME disc brakes with 50V coil.  
type : 660/650-5K/5D-645-45K-4WD-4CA2  
Polycarbonate case

**Operating conditions:**

- Casing protection standard IP66 IK08
- Ambient temperature : -20°C to +60°C

**Electrical data :**

Mains DC : 100 to 275 V DC ± 10%  
Possible operation in 115 V AC ± 20%

**EC marking of conformity :**

2006/95/EC directive BT (standard EN60204-1)  
2004/108/EC directive CEM (EN61000-6-2 EN61000-6-4)

**Options:**

- Closure delay of the caliper
- Disengageable closure delay of the caliper (cannot be combined with anti-condensation)
- Anti-condensation kit
- Steel case IP66 IK09

**ELECTRICAL DANGER : THIS PRODUCT IS NOT INSULATED**

Control and power electronic of power supply is not insulated and is under mains voltage.

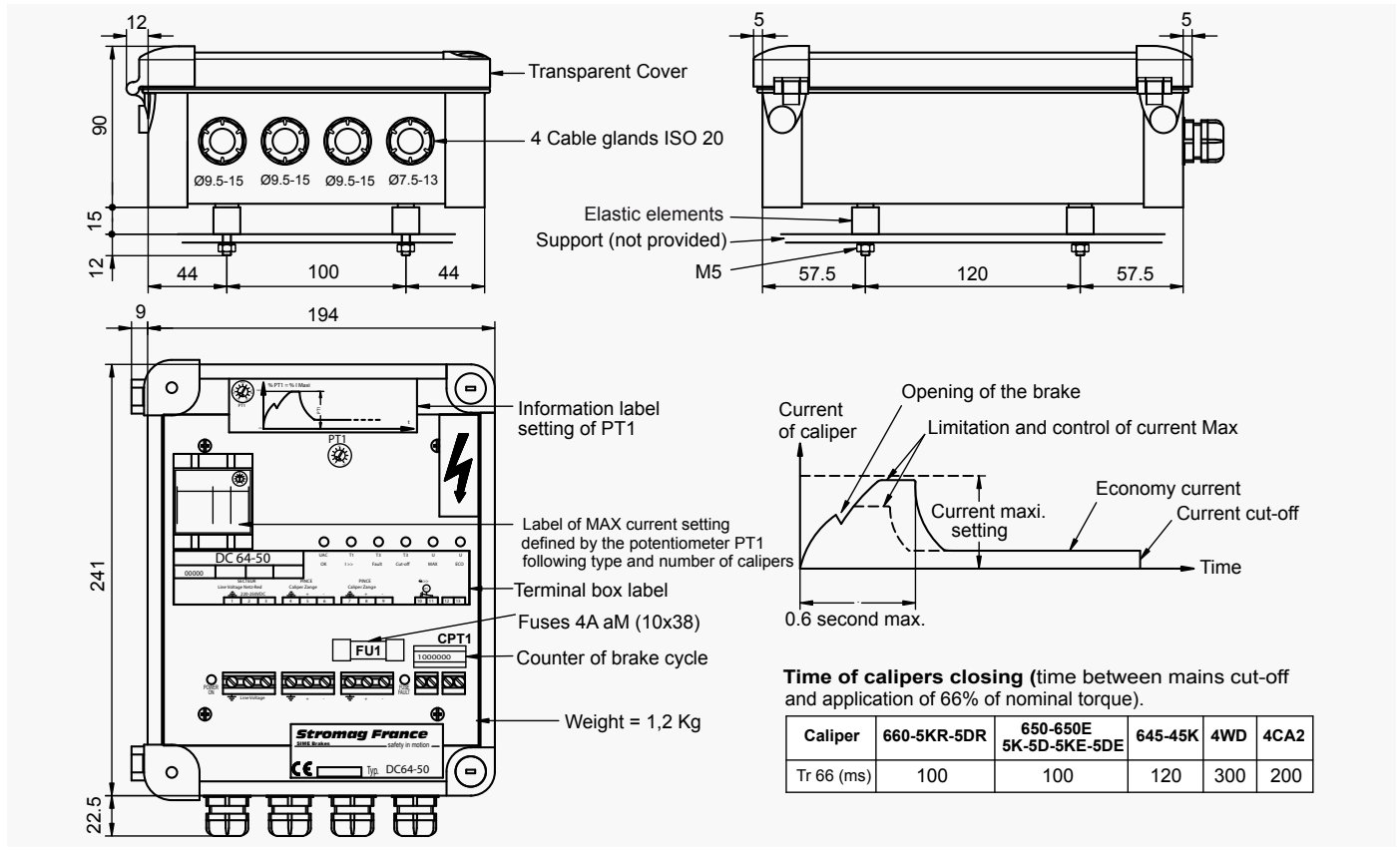

**Time of calipers closing (time between mains cut-off and application of 66% of nominal torque).**

Caliper	660-5KR-5DR	650-650E 5K-5D-5KE-5DE	645-45K	4WD	4CA2
Tr 66 (ms)	100	100	120	300	200

Caliper	660-650-650E	5K-5D-5KR-5DR 5KE-5DE	645	45K	4WD	4CA2					
Maximum number of calipers	2	2	2	2	2	1					
Resistance at 20°C per caliper (Ω)	6.68	6.68	4.52	4.52	4.52	3.08					
Maximum number of actuations per hour and ambient temperature θ	θ ≤ 40°C	150	1000	150	1000	60	1000				
	40°C < θ ≤ 60°C	150	600	150	600	60	600				
Mains current absorbed per caliper	Max (A)	3.5	3.5	5	5	5	9				
	Economy (A)	0.4	0.4	0.5	0.5	0.5	0.75				
Maximum return resistance of the cable connecting the caliper to the power supply (Ω)	2	2	1	1	1	1 *					
Max. length of the connecting cable (Power supply - caliper) for 1 caliper per cable, depending on cable section	2.5 mm² (m)	100	100	50	50	50	50 *				
	4 mm² (m)	160	160	80	80	80	80 *				
	6 mm² (m)	240	240	120	120	120	120 *				
Protection to be provided in head of control contactor on mains input	Number of caliper	1	2	1	2	1	2	1	2	1	
	Fuse aM (A)	1	2	1	2	2	4	2	4	2	4
	Circuit-breaker curve C (A)	1	2	1	2	2	4	2	4	2	4

\* If the ambient temperature of the caliper 4CA2 is higher than 60°C.

the maximum return resistance and the maximum length of the connecting cable given in the above table must be divided by 2.

### DISC BRAKE - ELECTRICAL POWER UNIT DC32-50 CP

Revision number: T10007-01-G

Revision date: 09.04.2018

Compact power supply operating on direct mains.  
For SIME disc brakes with 50V coil.  
type : 4CA2 - 3WD - 3CA2 - 2CA2  
Polycarbonate case

**Operating conditions:**

- Casing protection standard IP66 IK08
- Ambient temperature : -20°C to +60°C

**Electrical data :**

Mains DC : 110 to 275V DC ± 10%  
Possible operation in 115 V AC ± 20%

**EC marking of conformity :**

- 2006/95/CE directive Low Voltage (standard EN60204-1)
- 2004/108/CE directive EMC (standards EN61000-6-2 and EN61000-6-4)

**Options:**

- Closure delay of the caliper
- Disengageable closure delay of the caliper (cannot be combined with anti-condensation)
- Anti-condensation kit
- Steel case IP66 IK10

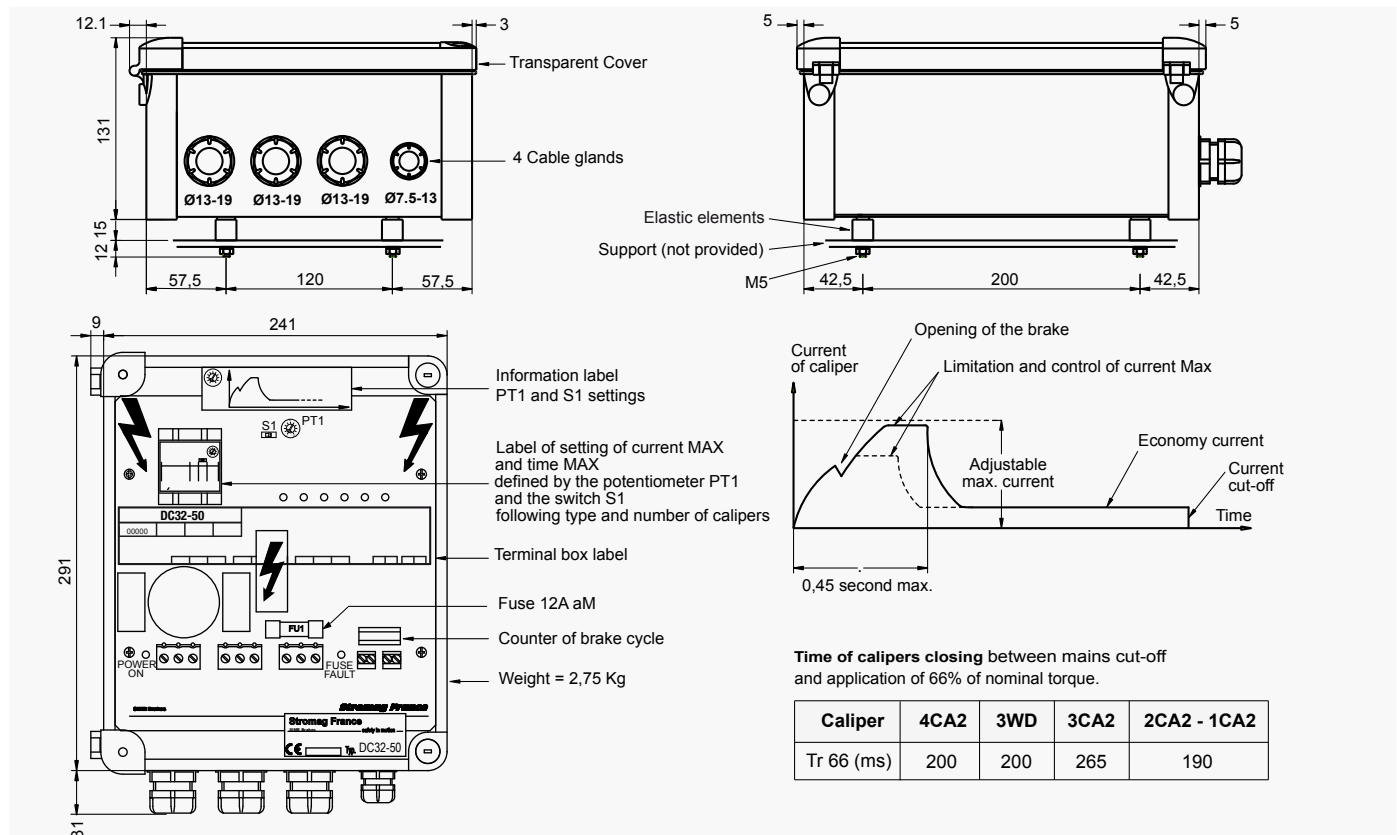

**ELECTRICAL DANGER : THIS PRODUCT IS NOT INSULATED**

Control and power electronic of power supply is not insulated and is under mains voltage. The power supply must be installed by qualified personnel, used to handle this equipment type and aware of risks inherent in their utilization.

Caliper		4CA2	3WD	3CA2	2CA2 1CA2	2CA2 + 20% 1CA2 + 20%
Maximum number of calipers		2	1	1	1	
Resistance at 20°C per caliper	(Ω)	3.08	1.63	1.01	0.75	
Maximum number of actuations per hour and ambient temperature θ	θ ≤ 40°C	1000	60	1000	1000	600
	40°C < θ ≤ 60°C	600	60	600	600	300
Mains current absorbed per caliper	Max (A)	9.9	18	24.1	36.9	
	Economy (A)	1.5	1.6	1.8	2.3	
Maximum connecting cable return resistance between caliper and supply unit	(Ω)	1	0.75	1	0.5	
Max. length of the connecting cable (Power supply/caliper) for 1 caliper per cable. depending on cable section	2.5mm² (m)	50	35	50	25	
	4mm² (m)	80	60	80	40	
	6mm² (m)	120	90	120	60	
	10mm² (m)	205	155	205	100	
Protection to be provided in head of control contactor on mains input	Fuse aM (A)	6	6	6	10	
	Circuit-breaker curve C (A)	8	8	10	16	

# SIME Brakes Industrial Braking Systems

## Electrical Power Units

### DISC BRAKE - ELECTRICAL POWER UNIT DS100-50 CP

Revision number: T10037-01-B

Revision date: 15.11.2016

Compact power supply operating on direct mains.  
For SIME disc brakes with 50 V coil  
type : OSA - OOSA  
Polycarbonate case

**Operating Conditions:**

- Casing protection standard IP66 IK08
- Ambient temperature : -20°C to +60°C

**Electrical Data :**

Mains DC : 110 to 275V DC  $\pm$  10%  
Possible operation in 115 V AC  $\pm$  20%

**EC marking of conformity :**

- 2006/95/CE directive Low Voltage (standard EN60204-1)
- 2004/108/CE directive EMC (standards EN61000-6-2 and EN61000-6-4)

**Options:**

- Closure delay of the caliper
- Disengageable closure delay of the caliper (cannot be combined with anti-condensation)
- Anti-condensation kit
- Steel case IP66 IK10

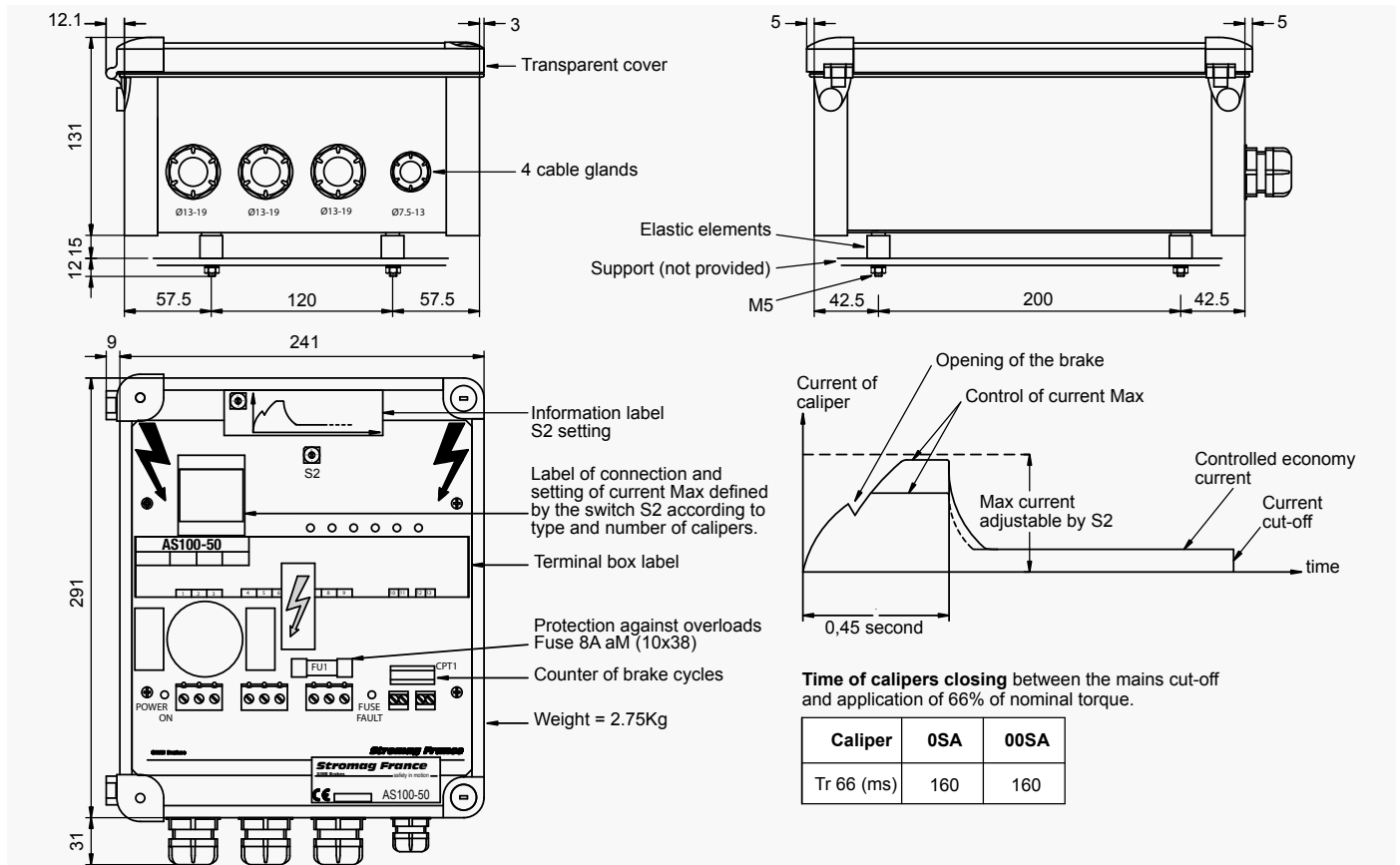

**ELECTRICAL DANGER : THIS PRODUCT IS NOT INSULATED**

Control and power electronic of power supply is not insulated and is under mains voltage.  
The power supply must be installed by qualified personnel. used to handle this equipment type and aware of risks inherent in their utilization.

Caliper		OSA	OSA	OOSA
Maximum number of calipers		1	2	1
Resistance at 20°C per electromagnet		Ω	1.01	1.01
Maximum number of actuations per hour and ambient temperature $\theta$	$\theta \leq 60^\circ\text{C}$		100	100
	Max	A	33	38
Mains current absorbed	Economy	A	2.6	3.3
			3.3	3.3
Maximum connecting cable return resistance between caliper and supply unit		Ω	3.5	1
Maximum connecting cable length (caliper-input) according to the cable section	2.5 mm <sup>2</sup>	m	170	50
	4 mm <sup>2</sup>	m	275	80
	6 mm <sup>2</sup>	m	415	120
	10 mm <sup>2</sup>	m	715	205
Protection to be provided in head of control contactor on mains input	Fuse aM	A	8	8
	Circuit-breaker curve C	A	16	16

### DISC BRAKE - ELECTRICAL POWER UNIT TYPE 4200

Revision number: T04800-01-C

Revision date: 21.10.2015

2 presentations are available:  
 - C for casing protected version  
 - P for plate mounted version

**Note:**  
 if 2 calipers are driven by the same power supply (or the 2 coils of the caliper OOSA) they must be connected in series (refer to the installation and maintenance leaflet)

**Operating conditions:**

- Line voltage:
  - direct: 115V to 600VDC  $\pm$  10%
  - single or three phases: 115V to 500VAC  $\pm$  10% 50/60Hz
- Ambiant temperature: -20°C to +55°C

**Type C4200 casing protected version**  
(casing IP 66 standard EN60529)

Weight: 17kg  
Dimensions in mm

**Type P4200 plate mounted version**  
(for cabinet assembly)

Weight: 8kg  
Dimensions in mm

CALIPER	Type	Number	4CA		3CA		OSA		OOSA		2SA	
			1	2	1	2	1	2	1	1	2	
Maximum number of actuations per hour at 40°C			700		1000		100				100	
Power consumption of the power supply	Maximum	W	1695	3215	1355	2480	2850	5380	5380	8205	15 815	
	Economy	W	105	140	130	175	305	480	480	205	300	
Max. connecting cable return resistance caliper to supply unit (for 1 coil)		Ω	1		1		1		1		1	
Delayed fuse rating to be provided between power supply and mains :												
direct :												
	115 VDC	A	25	25	25	25	25	25	25	35	35	
	230 VDC	A	25	25	25	25	25	25	25	35	35	
	400 to 600 VDC	A	25	25	25	25	25	25	25	35	35	
single phase :												
	115 VAC	A	25	25	25	25	25	25	25	35	35	
	230 VAC	A	25	25	25	25	25	25	25	35	35	
	400 VAC	A	25	25	25	25	25	25	25	35	35	
	500 VAC	A	25	25	25	25	25	25	25	25	25	
3 phases :												
Forbidden association	230 VAC	A	25	25	25	25	25	25	25	25	25	
	400 VAC	A	16	16	16	16	16	16	16	25	25	
	500 VAC	A	16	16	16	16	16	16	16	16	16	

# SIME Brakes Industrial Braking Systems

## Electrical Power Units

### DISC BRAKE - ELECTRICAL POWER UNIT TYPE 4205

Revision number: T04810-01-B

Revision date: 21.10.2015

Designed for normal control or progressive release of electrical calipers to perform lowering maneuvers.

2 presentations are available:  
 - C for casing protected version  
 - P for plate mounted version

**Operating conditions:**

- Line voltage:
  - direct: 115V to 600VDC  $\pm$  10%
  - single or three phases: 115V to 500VAC  $\pm$  10% 50/60Hz
- Ambient temperature: -20°C to +55°C

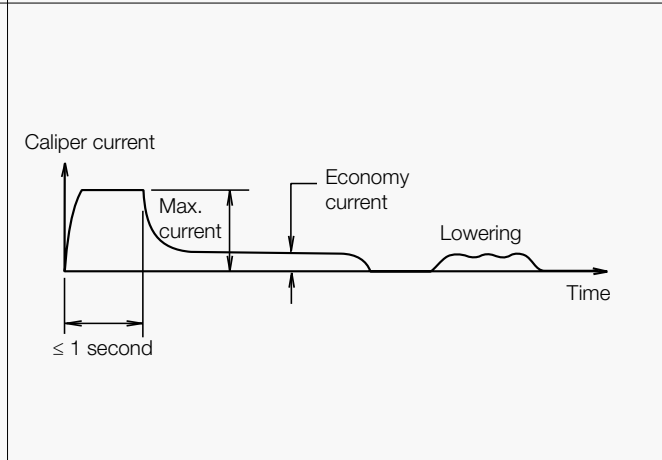
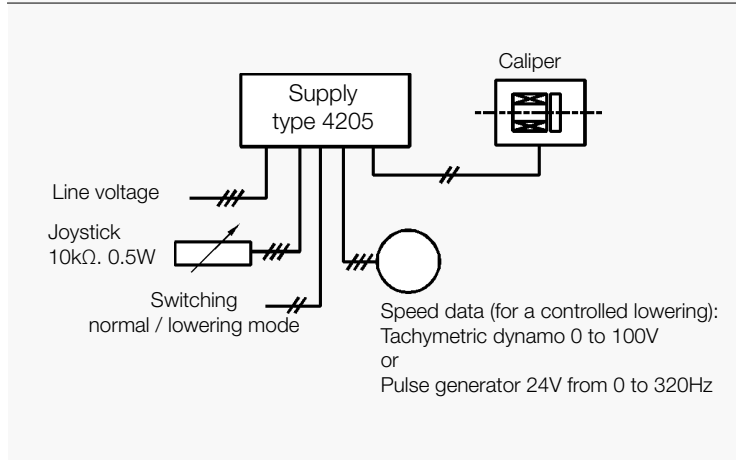
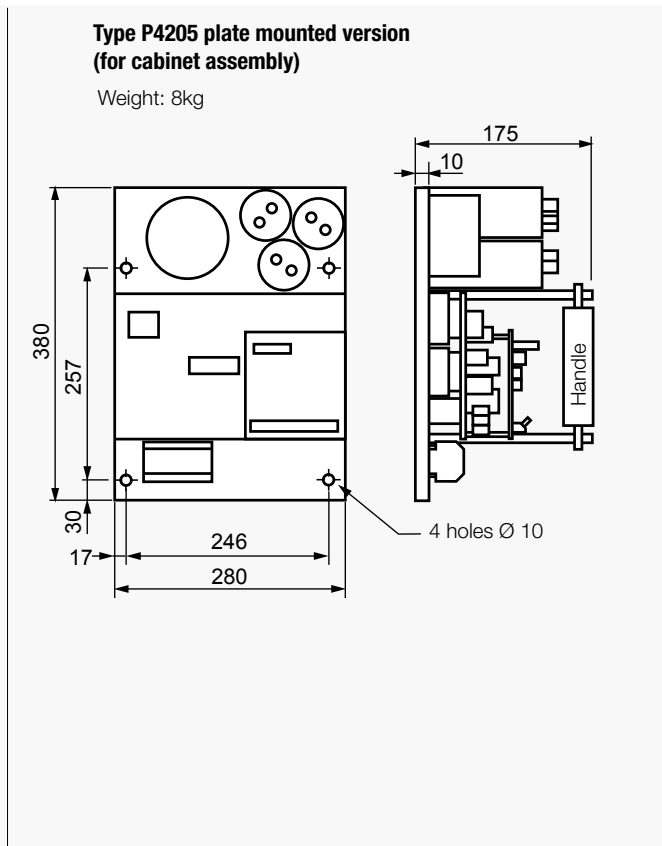
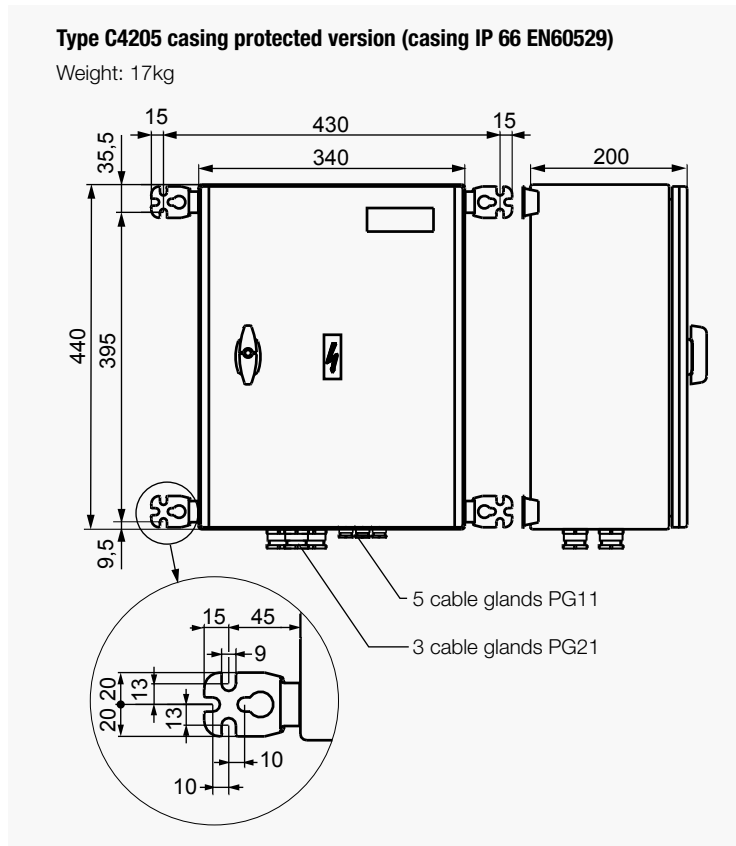

### DISC BRAKE - ELECTRICAL POWER UNIT TYPE 4205

Revision number: T04810-01-B

Revision date: 21.10.2015

**Notes:**

- Lowering a load is performed manually, with or without vertical speed control, by progressively releasing the calipers (between 100% and 50% of the nominal torque)
- 2 calipers driven by the same power supply (or the 2 coils of the caliper OOSA) must be connected in series (refer to the installation and maintenance leaflet)
- For lowering with calipers 4CA2, contact us.

Note : by insulated kinematics (e.g.: a drum), the lowering command is performed only for one of the **4205** electrical supply units. This unit is called the "master".  
One "master" unit can drive up to 5 "slave" units.

CALIPER	Type Number	4CA2		3CA2		OSA		OOSA	2SA		
		1	2	1	2	1	2	1	1	2	
Maximum number of actuations per hour at 40°C		700		1000		100			100		
Power consumption of the power supply	Maximum	W	1695	3215	1355	2480	2850	5380	5380	8205	15 815
	Economy	W	105	140	130	175	305	480	480	205	300
Max. connecting cable return resistance caliper to supply unit (for 1 coil)		Ω	1		1		1		1	1	
Delayed fuse rating to be provided between power supply and mains :											
direct :	115 VDC	A	25		25		25				
	230 VDC	A	25		25		25		35		
	400 to 600 VDC	A	25		25		25		35	35	
single phase :	115 VAC	A	25		25		25				
	230 VAC	A	25		25		25		35		
	400 VAC	A	25		25		25		35	35	
	500 VAC	A	25		25		25		25	25	
Forbidden association	3 phases :										
	230 VAC	A	25		25		25		25		
	400 VAC	A	16		16		16		25	25	
	500 VAC	A	16		16		16		16	16	





### DISC BRAKE - ELECTRICAL POWER UNIT TYPE AB8

Revision number: T04400-01-B

Revision date: 21/07/2016

Designed for control of the progressive braking effort by means of a foot pedal.

2 presentations are available:  
 - casing protected version C  
 - plate mounted version P

Matching CE markings:

- 73/23/CEE BT directive  
 - 89/336/CEE CEM directive  
 (specifications EN50081-2 EN50082-2 EN6 0204-1)

Working conditions:

- Voltage(single phase)  
 230/400V  
 or 400/415V  
 or 400/440V  
 or 400/460V  
 or 400/500V  
 ± 10% 50/60Hz
- Working ambient temperature:  
 -20°C to +60°C

**Type C AB8 protected version  
 (casing IP 669 standard DIN 40050)**

Weight: 16 kg

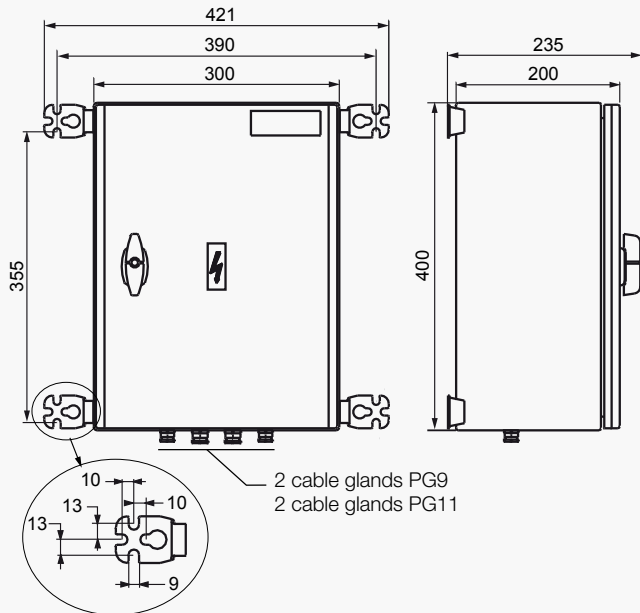

**Type P AB8 plate mounted version  
 (for cabinet assembly)**

Weight : 8 kg

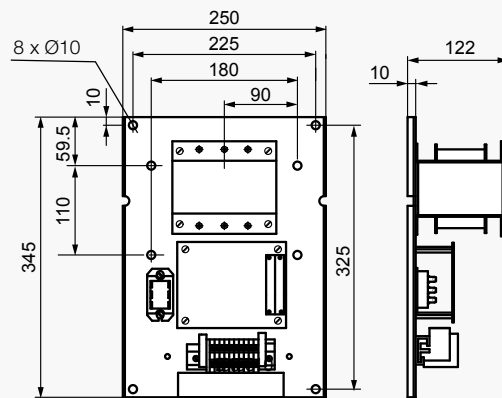

**Control pedal:**

it can drive 1 or 2 supply units AB8

Weight: 1.9kg

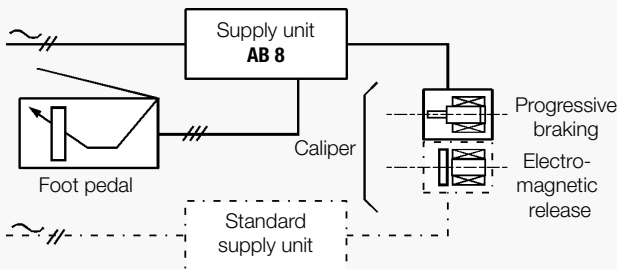
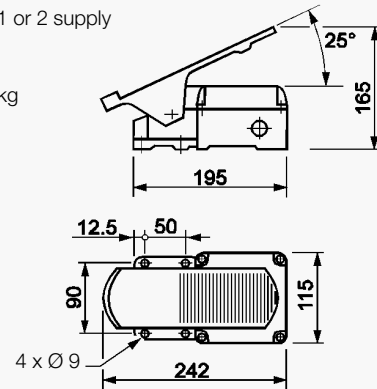

Caliper	650 E - 5 KE - 5 DE	
	1	2
Number of calipers	1	2
Power consumption in Watts for an output voltage of 20V DC	115	230
Voltage	3 to 24V DC	
Maximum connecting cable return resistance (caliper to supply unit)	Ω	0.5
Primary fuse DIN "NH" type. "aM" class to be provided	230 V	1A
	400/415 V	1A
	440/460/500 V	1A

# SIME Brakes Industrial Braking Systems

## Hydraulic Power Packs

# HYDRAULIC POWER PACKS

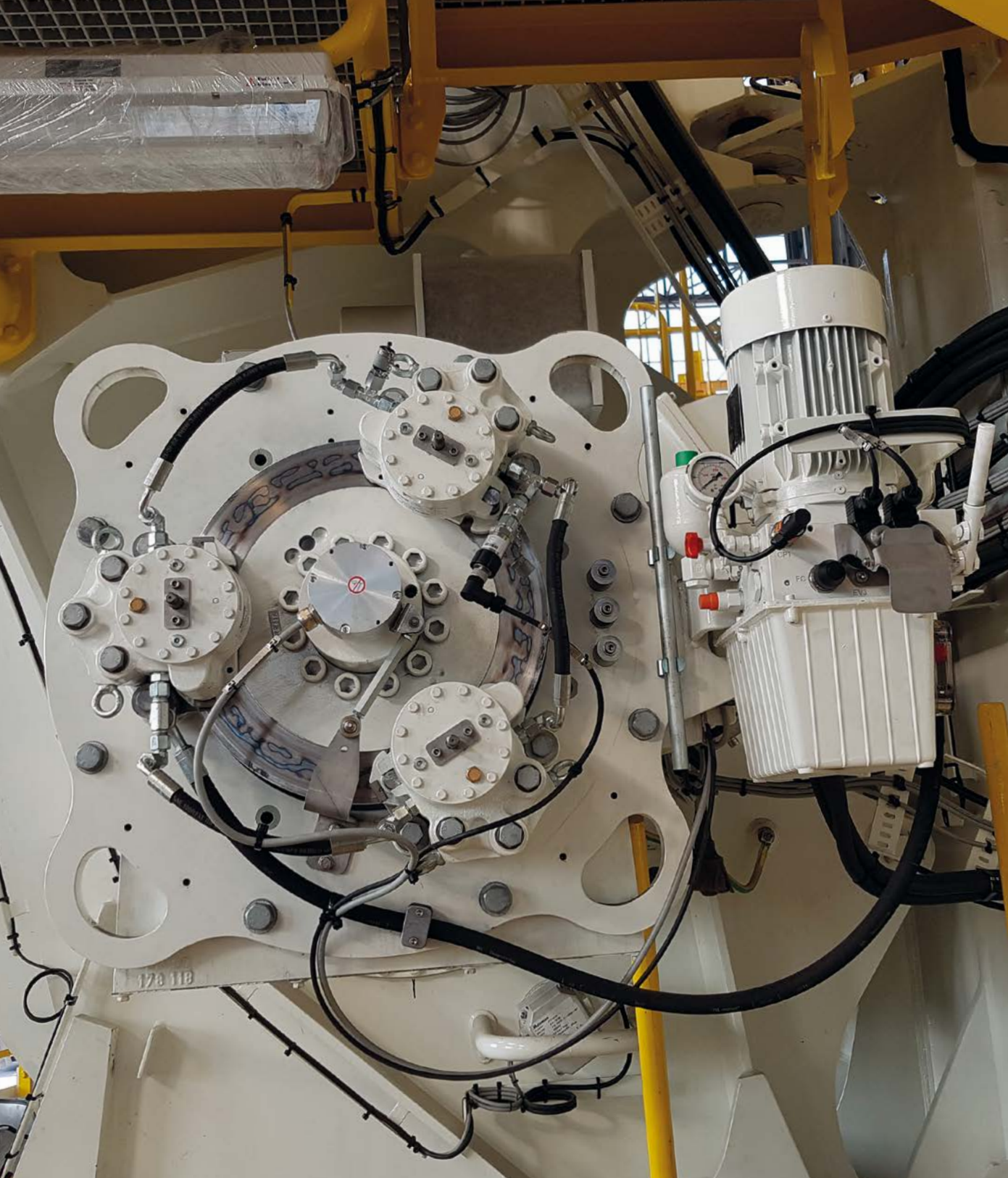

# SIME Brakes Industrial Braking Systems

## Hydraulic Power Packs

HYDRAULIC POWER PACKS	TANK	MAX. PRESSURE	ASSOCIATED CALIPERS	MAIN CHARACTERISTICS
<b>C3BSH</b> 	4 L	180 bars	<b>SHD2 - SHD5</b> <b>SH5 - SH9</b> <b>TH9</b>	<ul style="list-style-type: none"> <li>Vertical installation</li> <li>Options:                             <ul style="list-style-type: none"> <li><b>MS</b>: Special voltages motor</li> <li><b>OP1 / Y1-3</b></li> <li><b>Z1-Z2</b>: Delayed braking</li> <li><b>R</b>: Braking torque adjustment</li> <li><b>AF</b>: Lowering device</li> </ul> </li> </ul>
<b>CSH</b> 	6 L	200 bars	<b>SHD5 - SHD9</b>	<ul style="list-style-type: none"> <li>Vertical installation</li> <li>Customer-fitted solutions:                             <ul style="list-style-type: none"> <li>Application of full braking force</li> <li>Adjustable and progressive application fo the braking force with non-application of the full braking force at beginning of the braking</li> </ul> </li> <li>Electrical indicators (clogging, oil temperature and level)</li> </ul>
<b>CE8L</b> 	8 L	225 bars	<b>SHD2 - SHD5</b> <b>SH5 - SH9</b> <b>SH15 - SH18B</b> <b>SH25</b> <b>TH9</b>	<ul style="list-style-type: none"> <li>Horizontal or vertical installation.</li> <li>Options:                             <ul style="list-style-type: none"> <li><b>MS / OP1</b></li> <li><b>OP2</b>: Manual lowering with dead man safety device</li> <li><b>OP3</b>: Manual lowering with overspeed detection</li> <li><b>OP4</b>: Indicator of the valves position</li> <li><b>CS2EV</b>: Monitoring device of the 2 solenoid valves (<b>OP1</b>)</li> <li><b>Y5</b>: Regulated braking or lowering of the load</li> <li><b>OP6</b>: Tightness for Iron and steel industry</li> <li>Drip tray for HPP mounted horizontally</li> <li>Electrical power unit integrated to the HPP</li> <li>Electrical indicators: clogging, oil level and temperature...</li> </ul> </li> </ul>
<b>CE12L</b> 	12 L	225 bars	<b>SH15 - SH18B</b> <b>SH25 - SH32</b>	<ul style="list-style-type: none"> <li>Horizontal or vertical installation.</li> <li>Options:                             <ul style="list-style-type: none"> <li><b>MS / OP1 / OP2 / OP3 / OP4 / OP6</b></li> <li><b>OP9</b>: Output pressure switch</li> <li>Electrical power unit integrated to the HPP</li> <li>Electrical indicators: clogging, oil level and temperature...</li> </ul> </li> </ul>
<b>ST210</b> 	63 L	225 bars	<b>SH15 - SH18B</b> <b>SH25 - SH32</b>	<ul style="list-style-type: none"> <li>Vertical installation.</li> <li>Options:                             <ul style="list-style-type: none"> <li><b>MS / OP1 / OP2 / OP3 / OP4 / OP6</b></li> <li><b>OP9</b>: Output pressure switch</li> <li>Electrical power unit integrated to the HPP</li> <li>Electrical indicators: clogging, oil level and temperature...</li> </ul> </li> </ul>

# SIME Brakes Industrial Braking Systems

## Hydraulic Power Packs

### DISC BRAKE - C3BSH-ATH2 HYDRAULIC POWER PACK

Revision number: T05226-01-E

Revision date: 20.02.2014

Association with 1 caliper of **TH9**, **SH5** or **SH9A** range.

Maximal utilization pressure : 225 bars

Reservoir maximum oil volume : 4 L

Integrated electrical unit

#### Operating conditions:

- Ambient temperature: -10°C to +50°C
  - Relative humidity: ≤ 70%
  - Dust in atmosphere ≥ 65µm
  - Protection required against vertically falling water
- Other conditions: consult us.

#### Use:

- Frequency of operation : 100 op. / hour maxi.  
Except for SH5-6 and SH9-3 calipers :  
 frequency of operation : 60 op. /hour maxi.

#### Options:

- MS** Special motor
- OP1** Enhanced security return circuit by 2 solenoid valves
- R** Braking torque adjustment
- AF** Manual lowering with a dead man safety design
- OP6** Tight HPP for iron and steel industry
- Y1-3** Caliper closing with stepped braking torque application
- Z1-Z2** Delayed braking

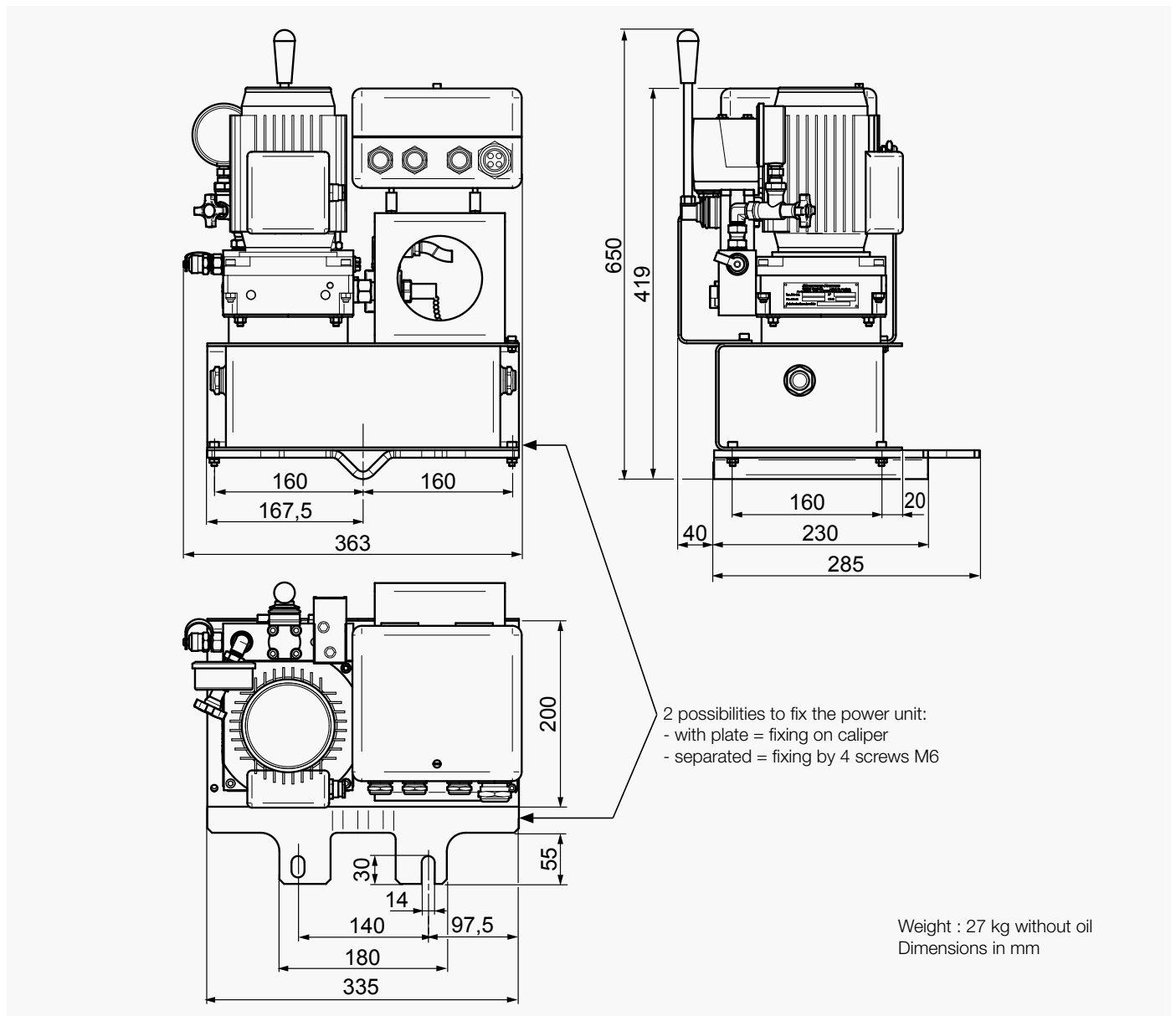

### DISC BRAKE - C3BSH-ATH2 HYDRAULIC POWER PACK

Revision number: T05226-01-E

Revision date: 20.02.2014



#### Electrical data

##### Motor M100

230/400VAC 50Hz 0.37 kW  
4 poles 1500rpm

##### For mains 3 phases

Frequency 50 Hz

220-230-240VAC ±10% 50Hz

380-400-415VAC ±10% 50Hz

Frequency 60 Hz

480VAC ±10% 60Hz

##### Solenoid valve EV100

Coil under 48 VRAC

##### Pressure switch CP100

- Protection: IP 65
- 240 V AC. 1.5 A
- 250 V DC - 0.1 A

#### Electrical unit connections

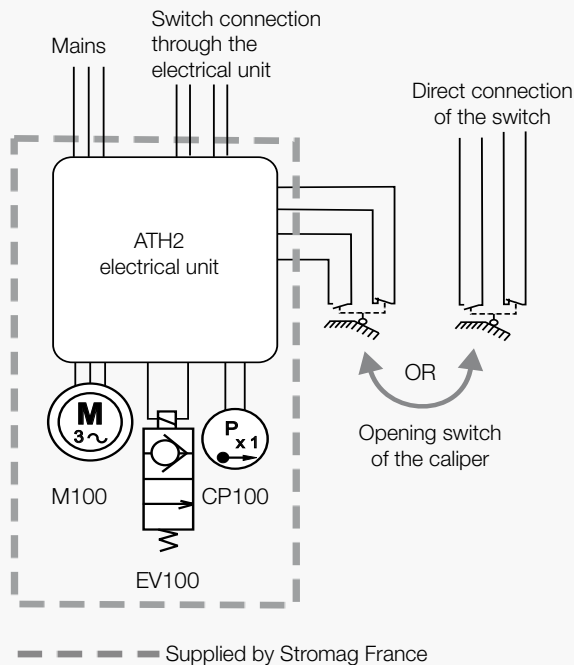

#### Flow diagram

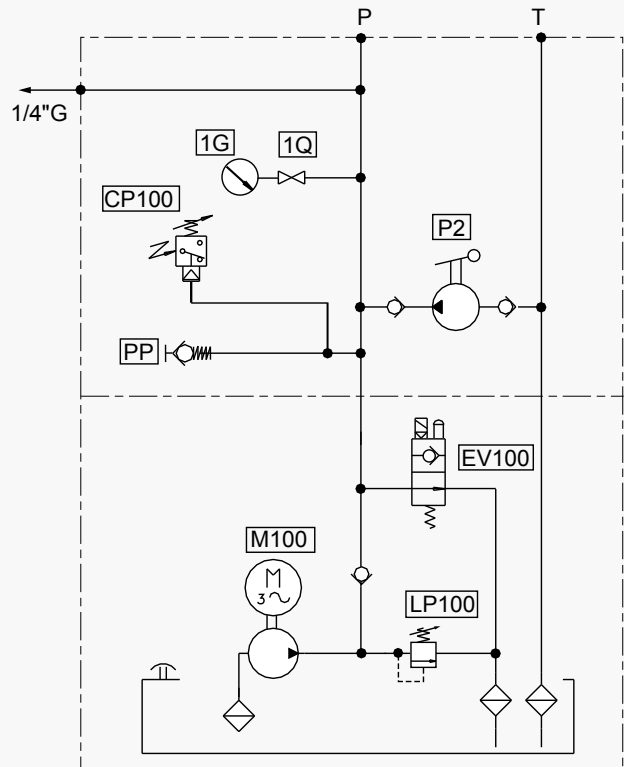

# SIME Brakes Industrial Braking Systems

## Hydraulic Power Packs

### DISC BRAKE - CSH-02 / CSH-09 / CSH-10 HPP

Revision number: T10123-02-F

Revision date: 14.11.2018

Association with 1 or 2 caliper(s): see table 1

Motor 0.75 kW at 1500 rpm

Maximal utilization pressure : see table 1

Electrical indicators of oil temperature and level (OP7-8)

Vertical installation

Soft-Braking :

Allow progressive and adjustable application of the braking force and non-application of the full braking force at the beginning of braking.

**Operating conditions:**

- Ambient temperature: -10°C to +50°C
  - Relative humidity: ≤ 100%
  - C4M L anti-corrosive protection level (according to ISO12944 standards)
  - IP55 tightness level
- Other conditions: consult us.

**Use:**

- Service life : 200 000 operations
- Frequency of operation : 60 op. / hour maxi.

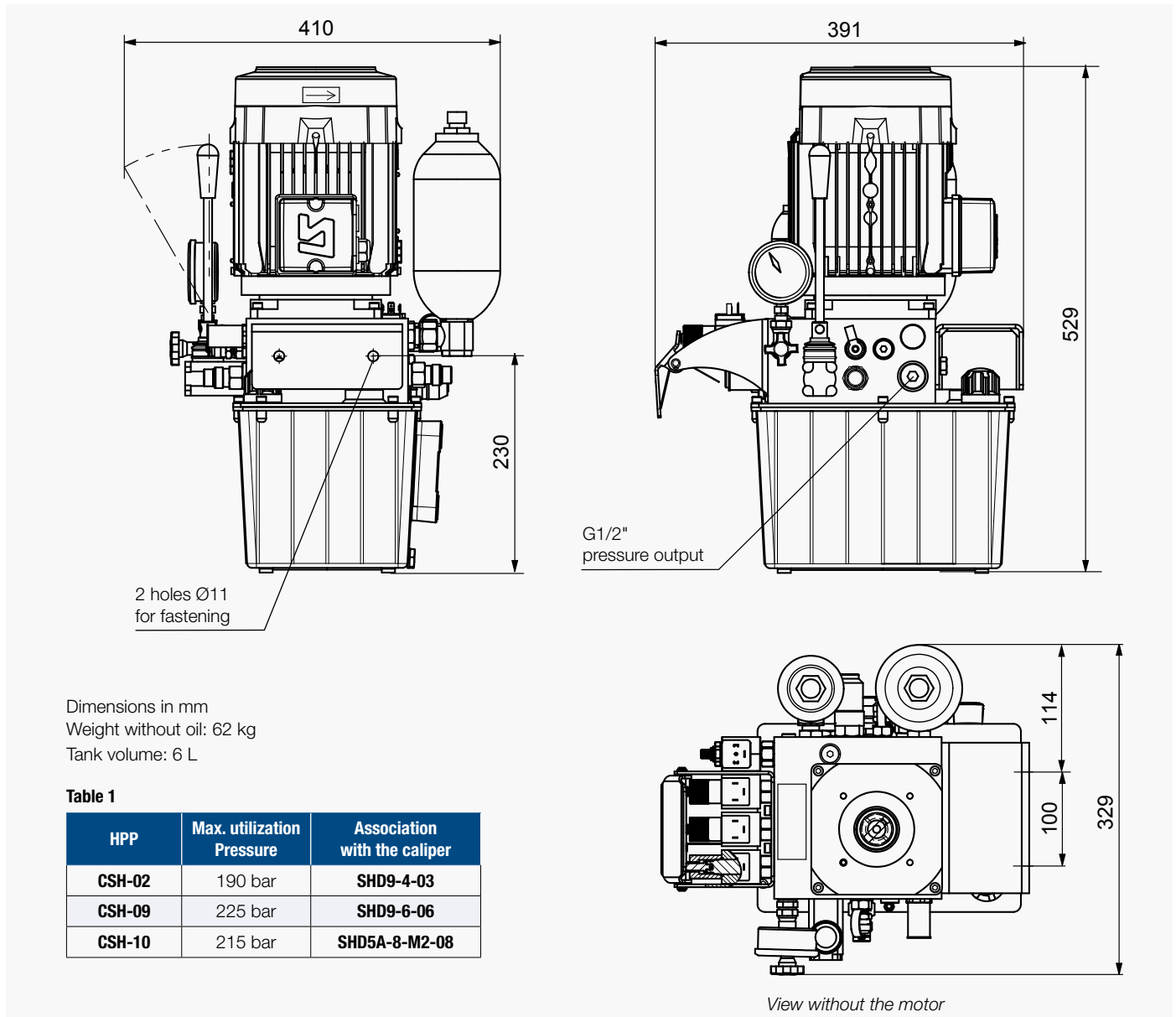

### DISC BRAKE - CSH-02 / CSH-09 / CSH-10 HPP

Revision number: T10123-02-F

Revision date: 14.11.2018

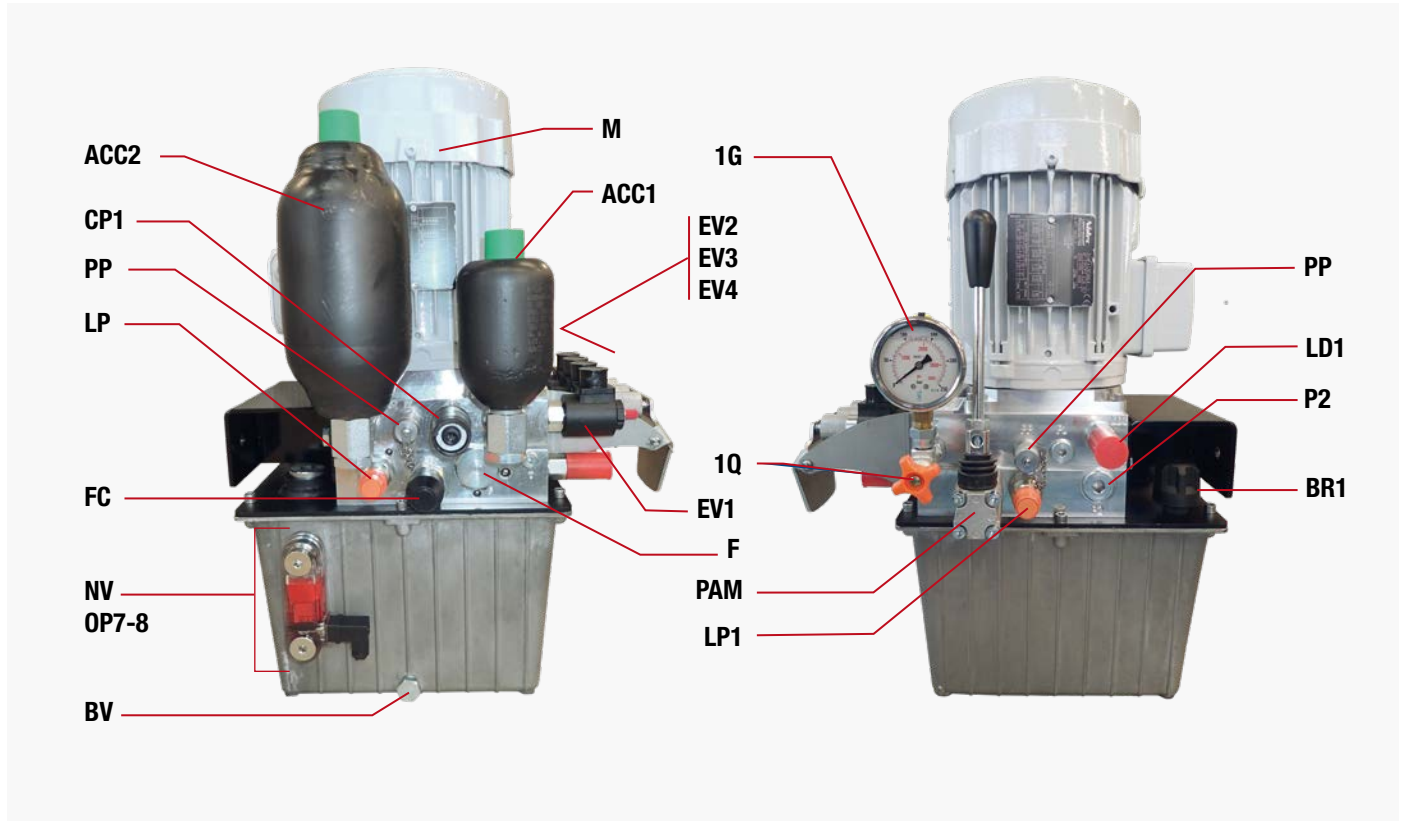

#### Electrical data:

##### Motor M

**230/400VAC 50Hz** 0.75 kW  
4 poles 1500rpm

For mains 3 phases	
Frequency 50 Hz	
220-230-240VAC ±10% 50Hz	
380-400-415VAC ±10% 50Hz	
Frequency 60 Hz	
265-277-290VAC ±10% 60Hz	
440-460-480VAC ±10% 60Hz	

##### Pressure switch CP1

- Electrical design : DC PNP
- Operating voltage : 9.6...32 VDC
- Current consumption : < 25 mA
- Insulation resistance : > 100 MΩ
- Current rating : 500 mA
- 2 switching outputs normally open / closed complementary
- Connector M12 / 5 positions in accordance with IEC61076-2-101 standard / code A (not delivered)

##### Solenoid valves EV1-EV2-EV3-EV4

Coil under 24VDC with rectifier  
DIN connector not provided

##### Electrical indicators of oil temperature and level OP7-8

Integrated to the visual oil level, the electrical indicators provide a temperature signal by means of a thermostat (NC) preset at 70°C (OP7) and a minimum oil level electric signal (INV) (OP8).

Electric part is completely separate from oil and insulated.

- Power commutable in DC : 40 W
- Power commutable in AC : 40 V.A.
- Current strength in DC - AC : 2 A
- Commutable voltage : 230 VDC/VAC
- Connector provided

# SIME Brakes Industrial Braking Systems

## Hydraulic Power Packs

### DISC BRAKE - CSH-02 / CSH-09 / CSH-10 HPP

Revision number: T10123-02-F

Revision date: 14.11.2018

Flow diagram

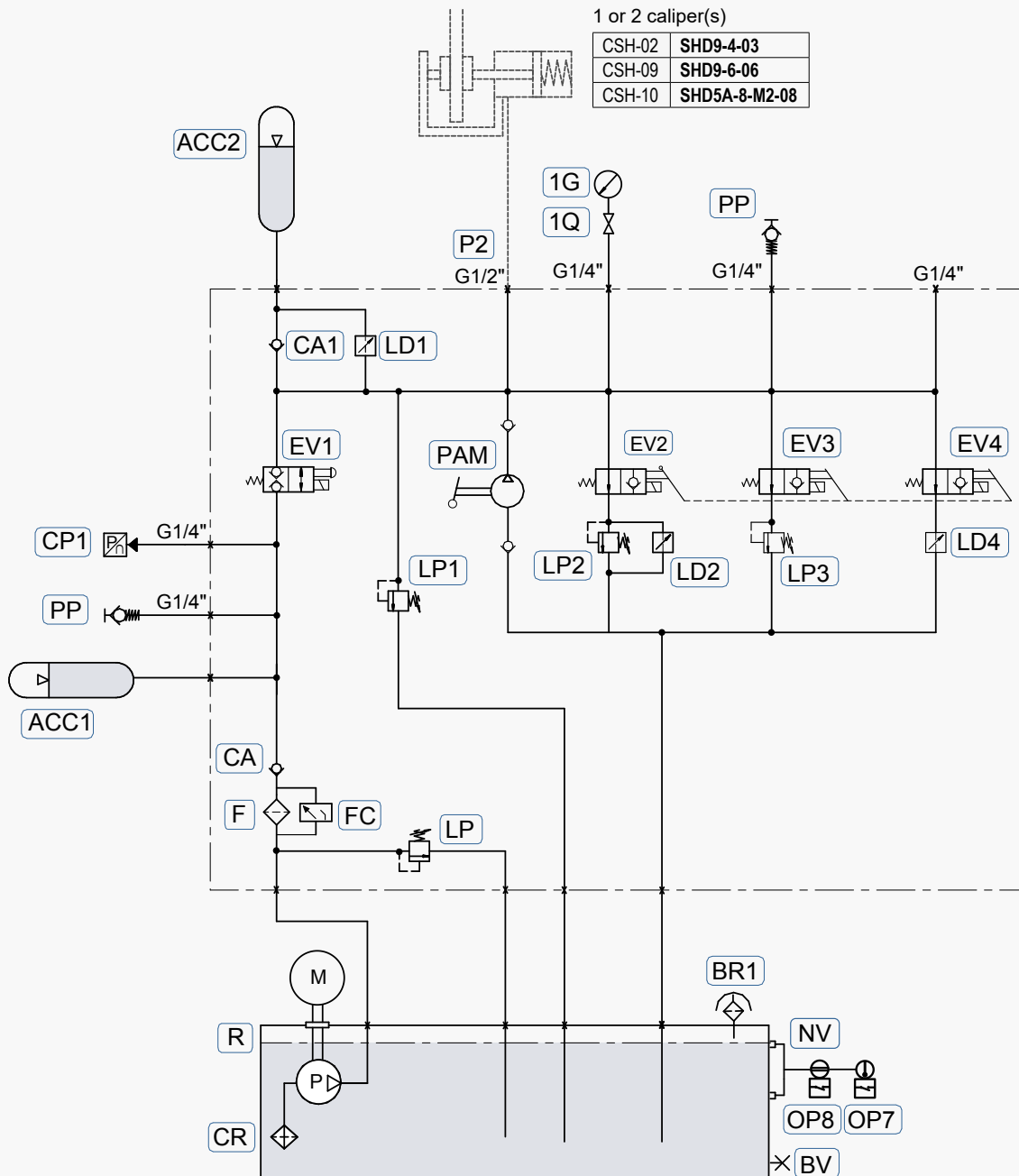





# SIME Brakes Industrial Braking Systems

## Hydraulic Power Packs

### DISC BRAKE - CE8L HYDRAULIC POWER PACK

Revision number: T05570-01-D

Revision date: 26.02.2015

Maximal utilization pressure : 225 bars  
 Reservoir maximum oil volume : 8 L  
 Vertical or horizontal installation

**Operating conditions:**

- Ambient temperature: -10°C to +60°C
- Relative humidity: ≤ 70%
- Dust in atmosphere ≥ 65µm
- Protection required against vertically falling waters

Other conditions: consult us.

**Use:**

- Frequency of operation : 100 op. / hour maxi.

**Association with the calipers :**

<b>CE8L-20</b>	SH25-2. SH18B. SH9-3. SH5-6
<b>CE8L-18</b>	SH15-3. SH9-2
<b>CE8L-16</b>	SH25-1. SH15-2. SH5-5. TH9-3
<b>CE8L-14</b>	SH15-1. SH9-1. SH5-4
<b>CE8L-11</b>	SH5-3. TH9-2

**Options :**

<b>MS</b>	Motor 290/500VAC 50Hz or Motor 230/400 VAC with PTC sensor
<b>EVS</b>	EV coils voltage different from the standard
<b>K1 or K2</b>	Integrated electrical power unit
<b>OP1</b>	Enhanced security return circuit by 2 solenoid valves
<b>CS2EV</b>	Monitoring device of the 2 solenoid valves (of OP1)
<b>OP1-OP2</b>	Manual lowering with a dead man safety device.

<b>OP1-OP3</b>	Manual lowering with overspeed safety by solenoid valve 24VDC.
<b>OP4</b>	Indicator switch of the position of the control valve(s)
<b>OP5</b>	Visual or electrical clogging Indicator
<b>OP6</b>	HPP for iron and steel industry
<b>OP8</b>	Electrical indicator of oil minimum level
<b>OP10</b>	Drip tray for horizontal HPP
<b>RV</b>	Drain valve for reservoir
<b>Y5</b>	Regulated braking

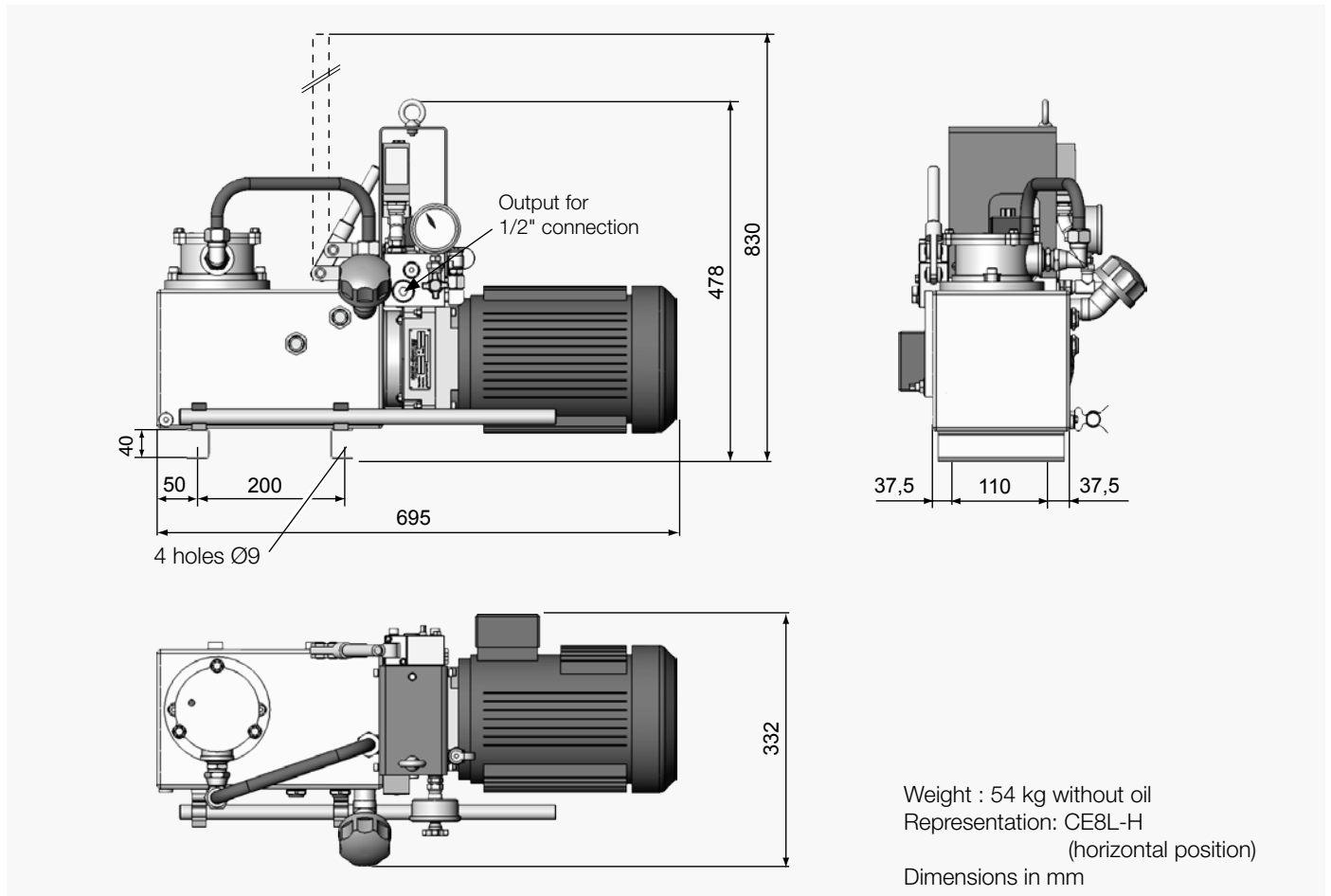

### DISC BRAKE - CE8L HYDRAULIC POWER PACK

Revision number: T05570-01-D

Revision date: 26.02.2015

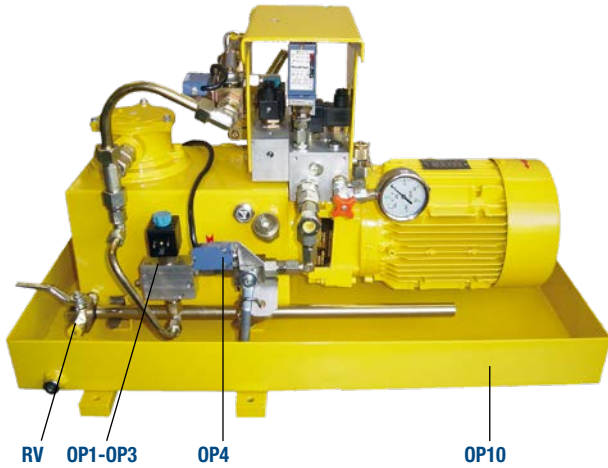

**Electrical data:**

**Motor M**

230/400VAC 50Hz 2.2 kW  
4 poles 1500rpm

For mains 3 phases

Frequency 50 Hz
220-230-240VAC ±10% 50Hz
380-400-415VAC ±10% 50Hz
Frequency 60 Hz
480VAC ±10% 60Hz

**Solenoid valve EV1**

Coil under 230VAC 50 or 60 Hz  
single phase. 20W  
Protection IP55

**Pressure switch CP1**

- Single-pole and snap-acting contact "OC"
- Protection: IP 66
- 240 V AC. 1.5 A
- 250 V DC. 0.1 A

**Flow diagram**

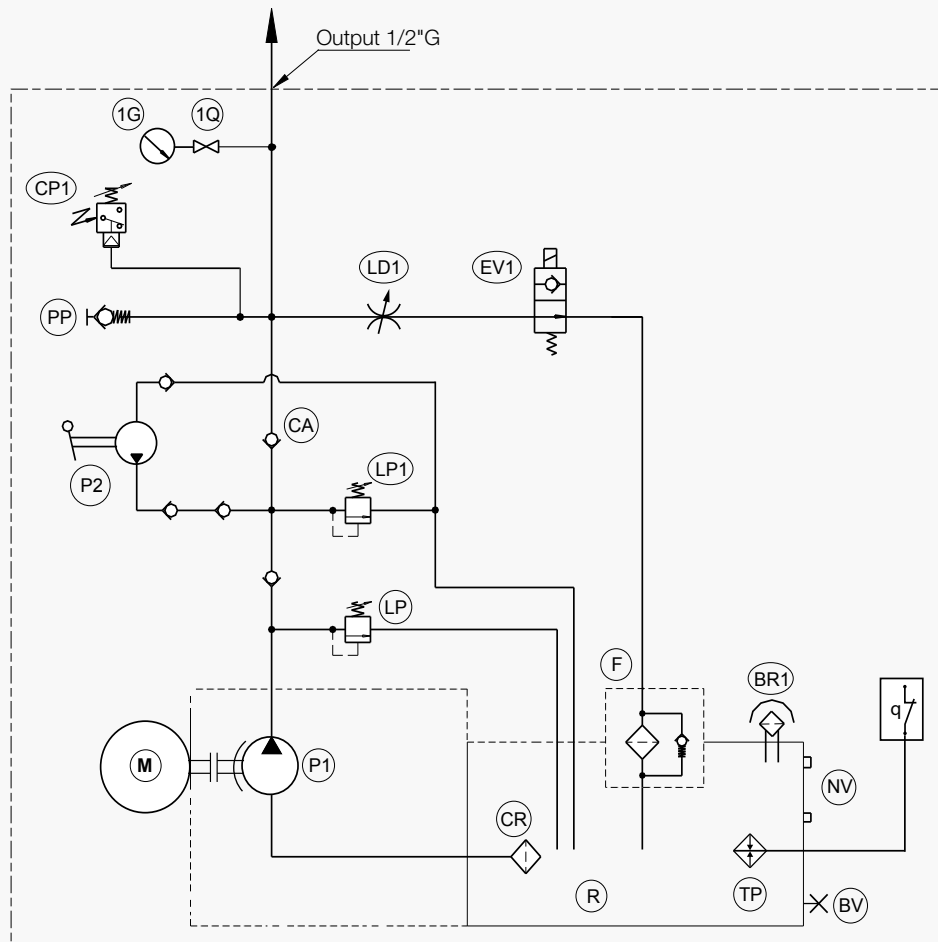

# SIME Brakes Industrial Braking Systems

## Hydraulic Power Packs

### DISC BRAKE - CE12L HYDRAULIC POWER PACK

Revision number: T10001-01-F

Revision date: 26.02.2015

Maximal utilization pressure : 225 bars  
 Reservoir maximum oil volume : 12 L  
 Vertical or horizontal installation

**Operating conditions:**

- Ambient temperature: -20°C to +60°C
- Relative humidity: ≤ 100%
- Dust in atmosphere ≥ 30µm
- Protection required against vertically falling waters

Other conditions: consult us.

**Use:**

- Frequency of operation : 100 op. / hour maxi.

**Association with the calipers :**

<b>CE12L-20</b>	SH25-2. SH18B
<b>CE12L-18</b>	SH15-3
<b>CE12L-16</b>	SH25-1. SH15-2
<b>CE12L-14</b>	SH15-1

**Options :**

<b>MS</b>	Motor 500VAC 50Hz or Motor 230/400 VAC with PTC sensor
<b>EVS</b>	EV coils voltage different from the standard
<b>K4</b>	Integrated electrical power unit
<b>OP1</b>	Enhanced security return circuit by 2 solenoid valves
<b>CS2EV</b>	Monitoring device of the 2 solenoid valves (of OP1)
<b>OP1-OP2</b>	Manual lowering with a dead man safety device.

<b>OP1-OP3</b>	Manual lowering with overspeed safety by solenoid valve 24VDC.
<b>OP4</b>	Indicator switch of the position of the control valve(s)
<b>OP5</b>	Visual (OP5) or electrical (OP5E) clogging Indicator
<b>OP6</b>	HPP for iron and steel industry
<b>OP7</b>	Electrical indicator of oil temperature
<b>OP8</b>	Electrical indicator of oil minimum level
<b>OP10</b>	Drip tray for horizontal HPP
<b>Y5</b>	Regulated braking

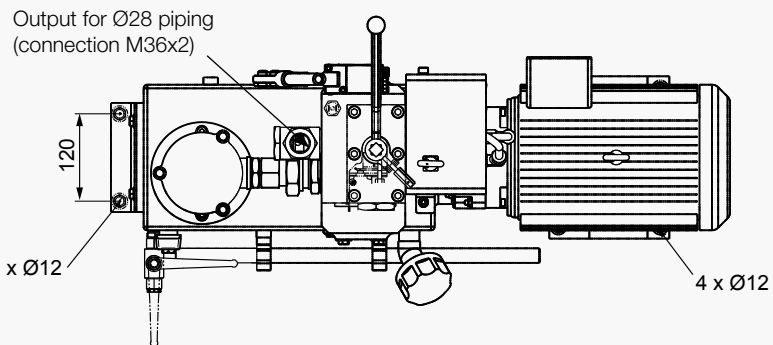
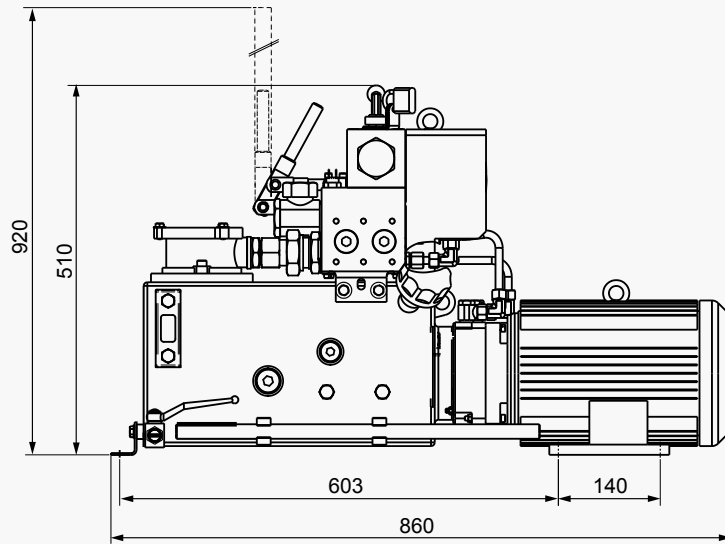
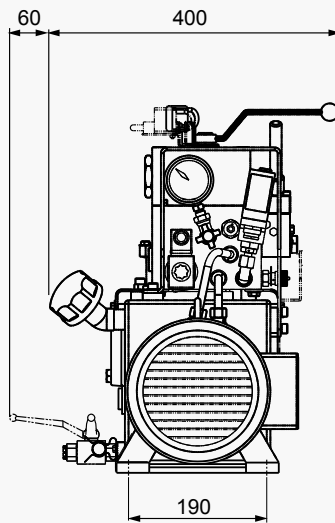

Weight : 66 kg without oil  
 Model : CE12L-H  
 (horizontal position)  
 Dimensions in mm

### DISC BRAKE - CE12L HYDRAULIC POWER PACK

Revision number: T10001-01-F

Revision date: 26.02.2015

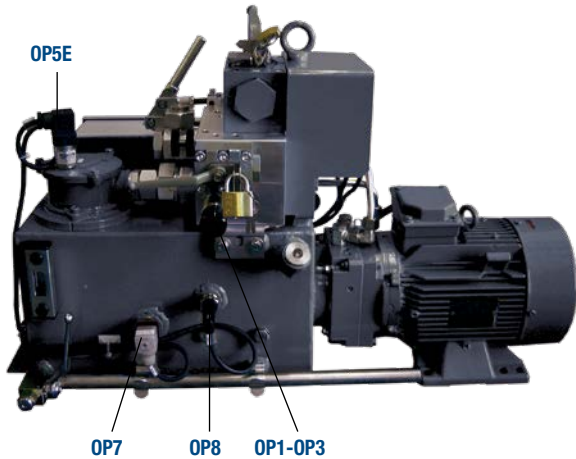

**Electrical data:**

**Motor M**

230/400VAC 50Hz 4 kW  
4 poles 3000rpm

For mains 3 phases	
Frequency	50 Hz
220-230-240VAC	±10% 50Hz
380-400-415VAC	±10% 50Hz
Frequency	60 Hz
220-230-240VAC	±10% 60Hz
440-460-480VAC	±10% 60Hz

**Solenoid valve EV1**

Coil under 230VAC 50 or 60 Hz  
single phase, 20W  
Protection IP55

**Pressure switch CP1**

- Single-pole and snap-acting contact "OC"
- Protection: IP 66
- 240 V AC. 1.5 A
- 250 V DC. 0.1 A

**Flow diagram**

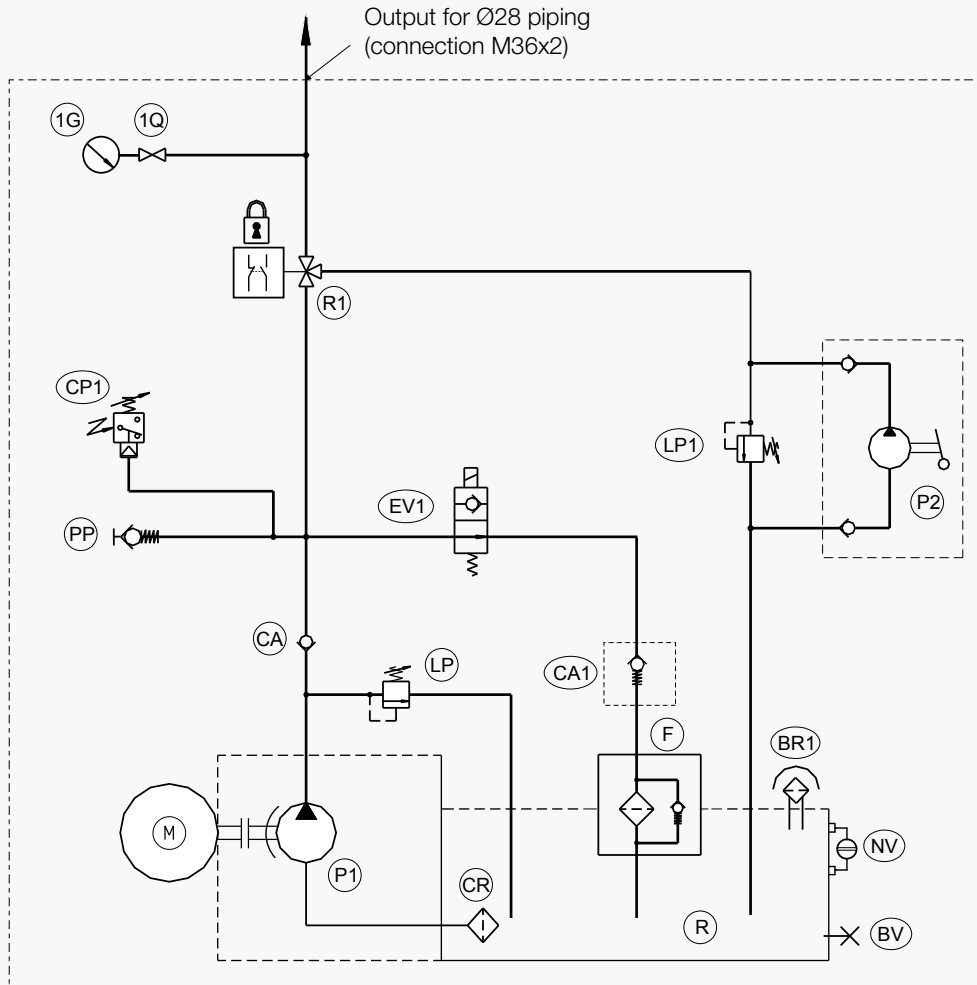

# SIME Brakes Industrial Braking Systems

## Hydraulic Power Packs

### DISC BRAKE - ST210 HYDRAULIC POWER PACK

Revision number: T05100-01-A

Revision date: 20.04.2002

Maximal utilization pressure : 225 bars

Reservoir volume : 78 L :

minimum oil volume = 42 L

maximum oil volume = 63 L

#### Operating conditions:

- Ambient temperature: -10°C to +50°C
  - Relative humidity: ≤ 70%
  - Particle size ≥ 40µm
  - Protection required against direct harm such as vertical falling waters, sea spray or flams.
- Other conditions: consult us.

#### Association with the calipers :

<b>ST210-20</b>	SH25-2. SH18B
<b>ST210-17</b>	SH15-3
<b>ST210-15</b>	SH25-1
<b>ST210-13</b>	SH15-2
<b>ST210-10</b>	SH15-1

#### Options :

<b>MS</b>	50 Hz : 240/415 V - 500 V 60 Hz : 260/460 V - 254/440 V
<b>EVS</b>	EV coils voltage different from the standard
<b>K</b>	Electrical unit (consult us)
<b>OP1</b>	Enhanced security return circuit by 2 solenoid valves
<b>OP1-OP2</b>	Manual lowering with a dead man safety device.
<b>OP1-OP3</b>	Manual lowering with overspeed safety by solenoid valve 24VDC.

<b>OP4</b>	Indicator switch of the position of the control valve(s)
<b>OP5</b>	Visual (OP5) or electrical (OP5E) clogging Indicator
<b>OP6</b>	HPP for iron and steel industry
<b>OP7</b>	Electrical indicator of oil temperature
<b>OP8</b>	Electrical indicator of oil minimum level
<b>OP9</b>	Output pressure switch

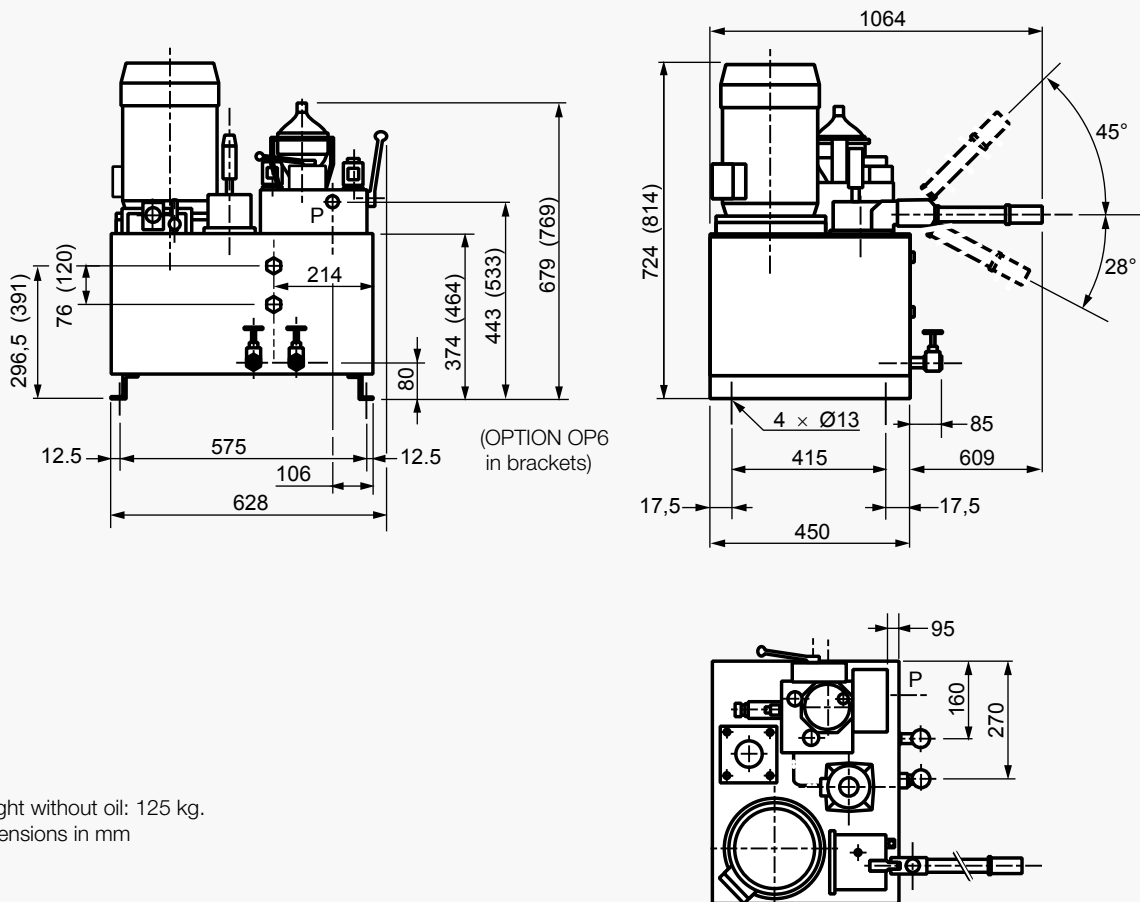

### DISC BRAKE - ST210 HYDRAULIC POWER PACK

Revision number: T05100-01-A

Revision date: 20.04.2002

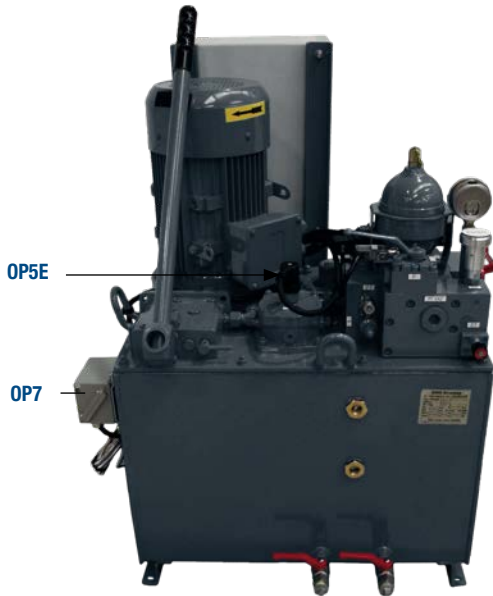

**Electrical data:**

**Motor**

230/400VAC ±5% 50Hz 4 kW  
 280/480VAC ±5% 60Hz  
 4 poles 3000 rpm  
 Protection: IP 55 classe F

**Solenoid valves**

- Power: 17 W, coil class H.
- 12 and 24 VDC.
- 24VRAC, 110VRAC and 220VRAC

**Pressure switch**

- Cable gland PG11
- Protection: IP 65
- Watertight housing
- Terminal box

For mains 3 phases
Frequency 50 Hz
220-230-240VAC ±10% 50Hz
380-400-415VAC ±10% 50Hz
Frequency 60 Hz
220-230-240VAC ±10% 60Hz
440-460-480VAC ±10% 60Hz

Flow diagram

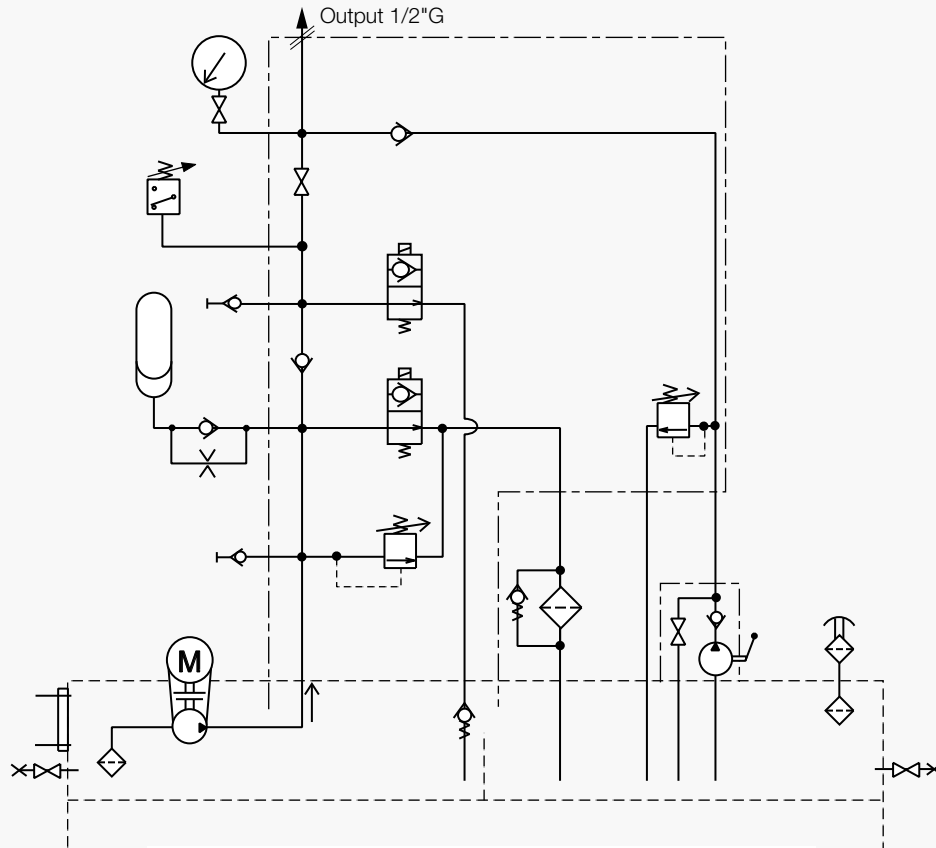

# SIME Brakes Industrial Braking Systems

## Safety Systems

# CONTROL AND SAFETY SYSTEMS

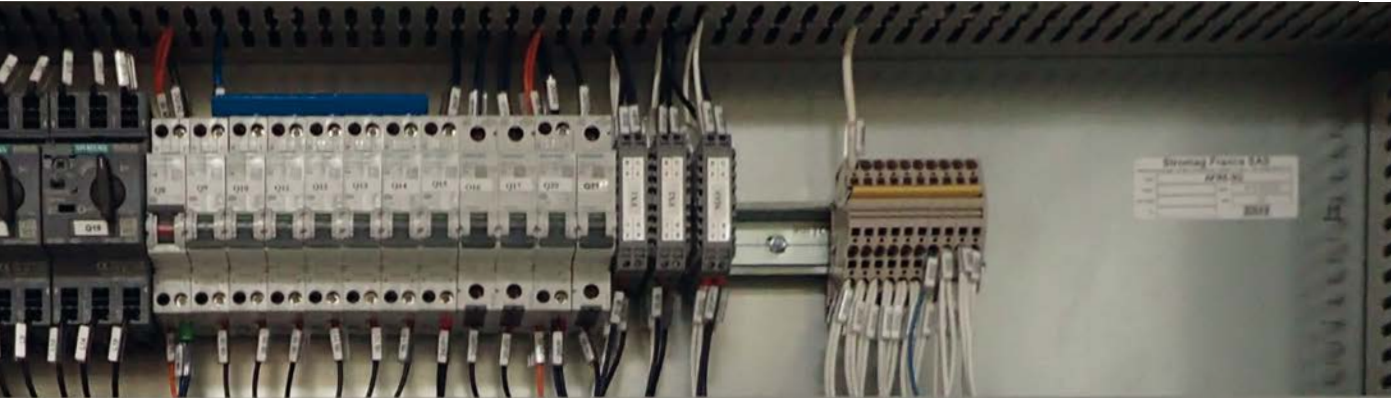



BRAKING SOLUTIONS FOR	APPLICATIONS
<ul style="list-style-type: none"> <li>• MONITORING THE HOISTING SPEED</li> <li>• REGULATED DECELERATION</li> <li>• SPEED REGULATION CONTROL</li> <li>• CONSTANT DECELERATION</li> <li>• SAFETY PERFORMANCE LEVEL PL d to PL e</li> </ul>	<ul style="list-style-type: none"> <li>• MASS TRANSPORTS : CABLEWAY, PASSENGERS ELEVATORS FUNICULARS, CHAIRLIFTS...</li> <li>• STEEL INDUSTRY LADLE CRANE</li> <li>• BELT CONVEYORS</li> </ul>



**SIDEOS One**

- SAFETY SYSTEM
- configurable and secure module for speed monitoring.
- fitted with an efficient auto-control system.



**CRD® / CRV®**

- CONTROL SYSTEMS
- speed regulation with **CRV®** module.
- setting of the deceleration rate on the **CRD®** module.



**AFR5**

- MONITORING. CONTROL SYSTEMS for regulated braking.
- SAFETY SYSTEMS adapted to the customer installation.
- includes **SIDEOS One** and **CRD®** modules

### ASSOCIATION OF 2 SIDEOS One - Detection of any kinematic linkage break

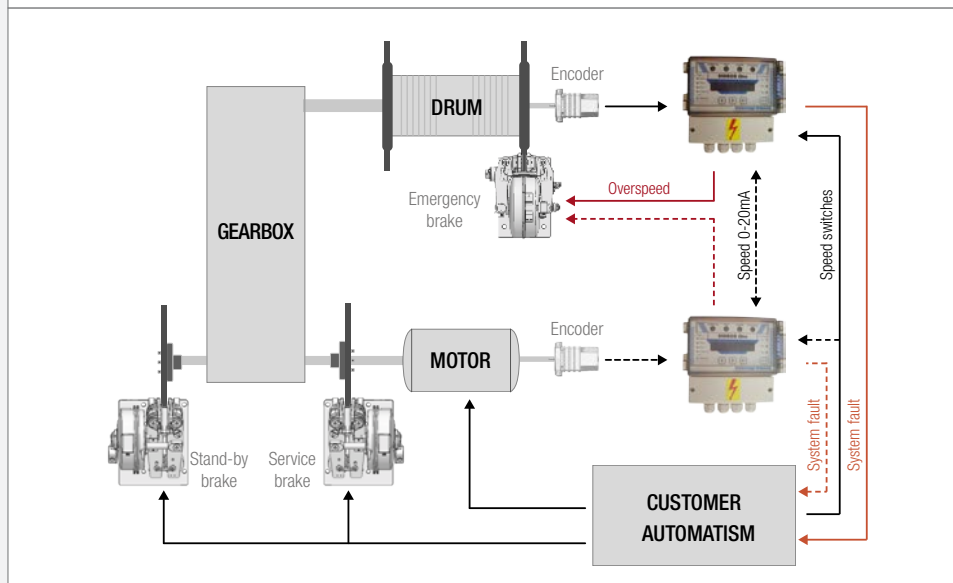

# SIME Brakes Industrial Braking Systems

## Safety Systems

### SAFETY SYSTEMS - SIDEOS ONE

Revision number: M10054-01-E

Revision date: 16.11.2018

Configurable and secure system for speed monitoring: redundant design and fault detection system (DC>99%) which secure the overall operation of the overspeed detection system.

**Conform to the machine security standards :**

NF EN ISO 13489-1  
 Performance level PL=d to PL=e  
 Category : 2 to 4  
 MTTFd = high DC = high

**Operating conditions :**

- Ambient temperature : -20°C to +60°C
- IP65 protected electrical casing

**Electrical data :**

- 2 versions  
 AC : 115/230 VAC ± 10% 50/60Hz or  
 DC : 24 VDC ± 15%
- Other voltages : consult us

**EC marking of conformity :**

- 2006/42/EC directive Machine
- 2014/35/UE Low voltage directive (standard NF EN 60204-1)
- 2014/30/UE EMC directive (standards NF EN 61000-6-2. NF EN 61000-6-4)

**Options :**

- Steel casing IP66 IK10
- Contact module

The **SIDEOS One** can be installed in a control enclosure on an DIN rail of 35mm, or fixed with M5 screws, see the drawing below.

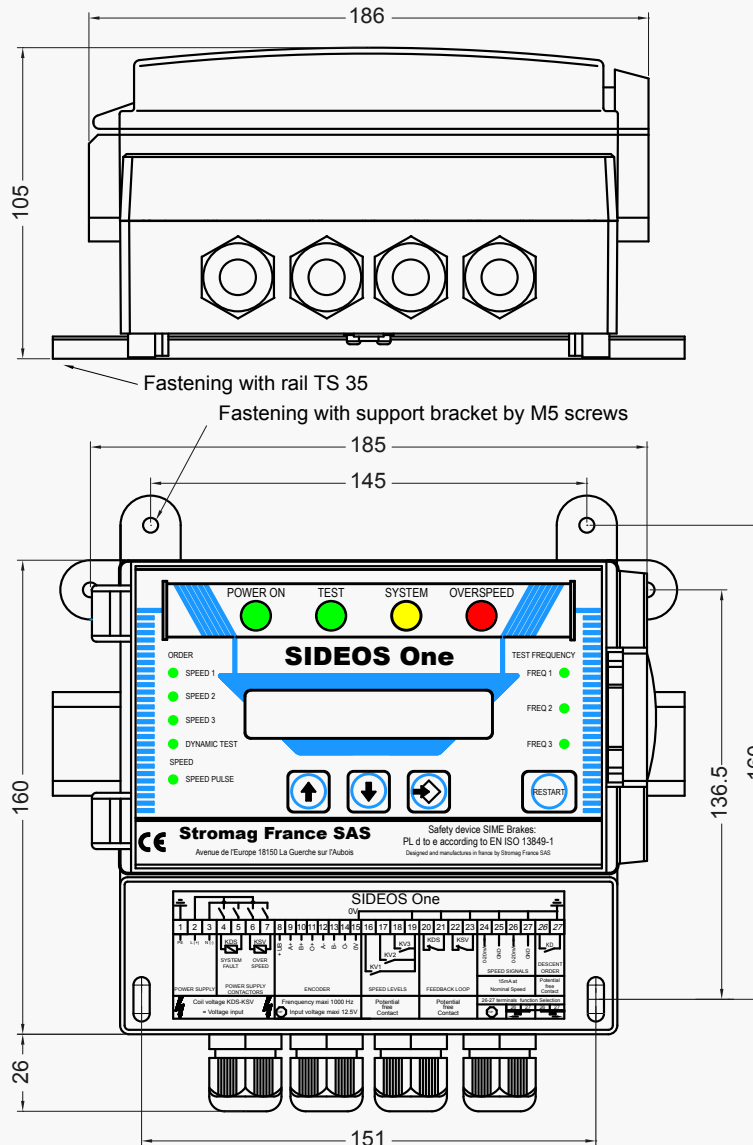

4 cable glands ISO20 cable Ø 6 to 12

In case of heavy vibrations, it is recommended to fasten the **SIDEOS One** on elastic buffers.

### SAFETY SYSTEMS - SIDEOS ONE

Revision number: M10054-01-E

Revision date: 16.11.2018

The **SIDEOS One** is a configurable system for speed monitoring designed to secure the lifting of a handling equipment.

> **It is set according to:**

<ul style="list-style-type: none"> <li>- <b>The lifting characteristics</b> <ul style="list-style-type: none"> <li>• Number of encoder pulses per revolution</li> <li>• Nominal speed of lifting in rpm</li> <li>• Deceleration time</li> </ul> </li> </ul>	<b>Parameters</b> NC NS DT
<ul style="list-style-type: none"> <li>- <b>The selected functions</b> <ul style="list-style-type: none"> <li>• Speed thresholds to monitor</li> <li>• Dynamic Slipping</li> <li>• Break of the kinematic chain</li> <li>• Encoder monitoring</li> </ul> </li> </ul>	SP1-SP2-SP3 TS TS and DS RC
<ul style="list-style-type: none"> <li>- <b>The number of pulses to confirm an Overspeed</b> <ul style="list-style-type: none"> <li>• Validation Overspeed 1, Static and Dynamic Slippings</li> <li>• Validation Overspeed 2</li> <li>• Validation Overspeed 3 and kinematic chain break</li> </ul> </li> </ul>	VS1 VS2 VS3



Access to the parameters is protected by a locking mode.

> **It receives:**

- The speed signal(s) of the installation
- The functional orders of the lifting control of the handling equipment

> <b>It monitors:</b>	<b>and detects, in case of wrong operation:</b>
- the lifting speed(s)	- an Overspeed
- the lifting stop (deceleration)	- a Static Slipping
- the lifting stop positioning	- a Static Slipping
- the lifting operation direction	- a Dynamic Slipping
- the lifting kinematic chain	- a Differential Speed
- the encoder	- an encoder fault
- the functional orders of the control	- a Speed contact fault
- the output contactors or relays	- a contactor fault

> **When it detects a fault, it pilots:**

- the opening of the independent output contactors, their power contacts being inserted in the supply circuit of the safety brakes.

> **It secures the global operation of the speed monitoring system by means of:**

- its redundant internal and external design and its monitoring system (DC > 99%) which allow the detection of all the internal and external failures.

> **It signals the triggering origin:**

- via the alphanumeric display
- an auxiliary contact of the output contactors

> **It records:**

- The opening of the output contactors or relays and this even in case of power cut
- The 3 last Fault message

> **It releases:**

- the fault when the RESTART button is manually actuated, this action allows the control system to receive a distinct starting order.

**It allows to obtain  
a secured speed monitoring system  
Category 2 PL d up to Category 4 PL e  
according to the standard NF EN ISO 13849-1.**

# SIME Brakes Industrial Braking Systems

## Safety Systems

### SAFETY SYSTEMS - SIDEOS ONE

Revision number: M10054-01-E

Revision date: 16.11.2018

#### Internal design

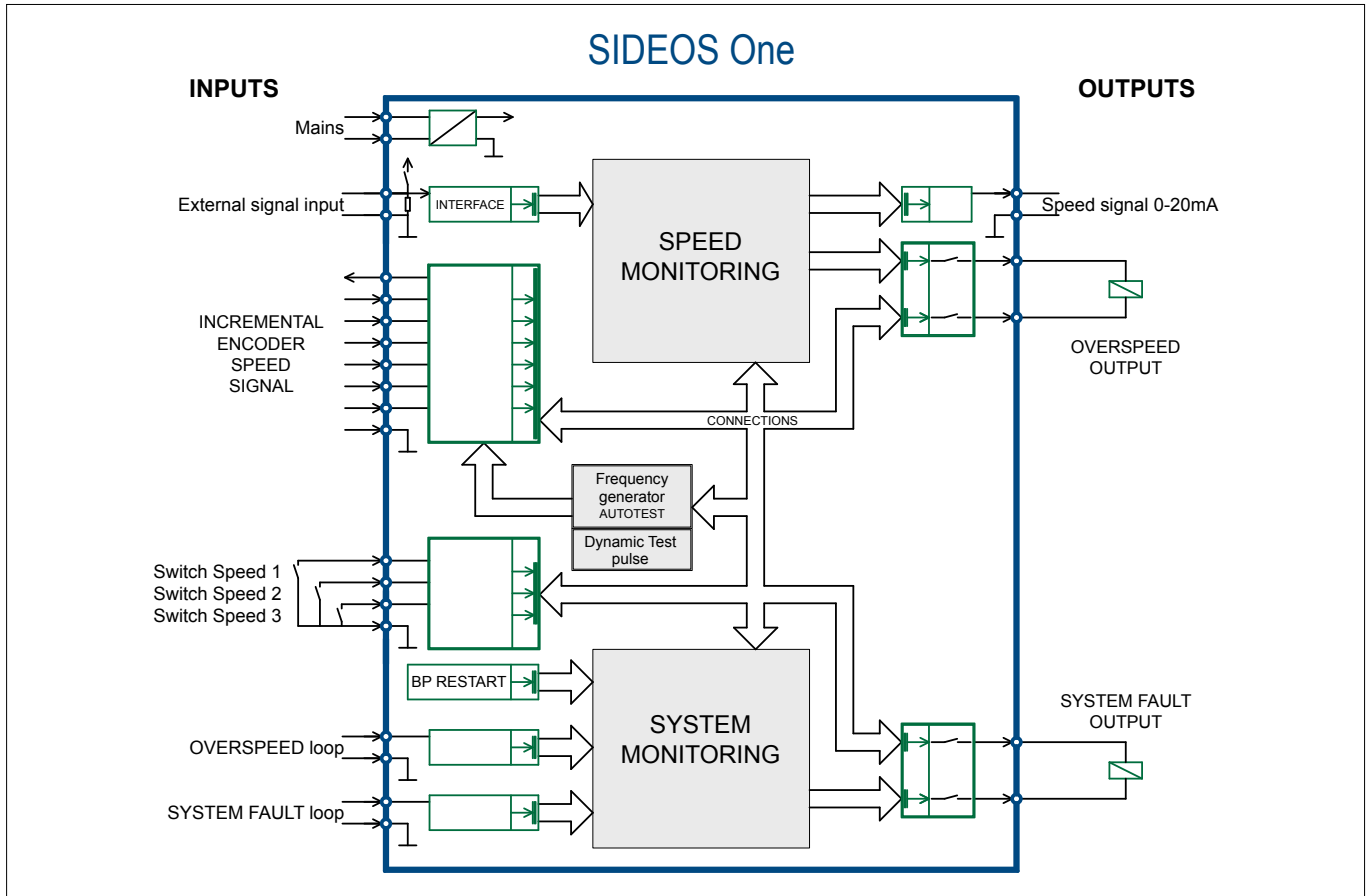

#### > External failures

The monitoring system of the **SIDEOS One** is designed to detect all the external signals failures by means of a redundant or logic treatment of the input signals.

It secures the operation of the speeds inputs, the contacts inputs, the System Fault outputs and the Overspeed outputs (DCavg>99%).

#### > Internal failures

The **SIDEOS One** detects all the internal faults (DCavg>99%), either during the operation, or during the AUTOTEST.

Faults, detected only during the AUTOTEST, do not lead to loss the safety function thanks to the redundant internal design.

It ensures :

- a cross-monitoring of its internal operation
- a dynamic test of the overspeed function every 360 pulses of the encoder
- the control of validity of the memories

#### > Cut-off and safe connection of the System Fault and Overspeed outputs supply

The **SIDEOS One** system, that cuts off the supply of the System Fault and Overspeed outputs, is designed to switch off the output supply whatever the fault present on the output.

#### > Autotest

The Autotest triggers automatically at power on (time 1.5s) or at a manual starting-up (RESTART) following a triggering of a **SIDEOS One** output (time 1s).

The AUTOTEST allows a global checking and ensures the **SIDEOS One** to operate correctly, if the AUTOTEST is validated.



## Safety Systems

# DISC BRAKE - CONSTANT DECELERATION CRD MODULE

Revision number: M08950-01-C

Revision date: 03.06.2015

### 1 - PRESENTATION

The **CRD®** module, combined with **5KE. 650E. TY5. TH** and **SH** type brakes allows a constant deceleration regulated braking (fig. 1) whatever the speed, the load and the kind of load, driving or resisting.

Applications: cableways, chairlifts, funiculars, lifts, belt conveyors, transporters ...

### 2 - PRINCIPLE

**CRD®** system (fig. 2) consists of:

- 1 or more brakes (progressive brakes type **5KE. 650E. TY5. TH** and **SH**).
- 1 hydraulic pack (**STE210Y5. CE8L-RY5**) or 1 electric power supply (AB8. ATP2. ATP24).
- 1 (or more) speed sensors (tachometric dynamo..).
- 1 **CRD®** module, it may be integrated into an **AFR5** enclosure supplied by Stromag France.

Two **CRD®** versions exist:

- **CRD-R**: a deceleration regulation board (fig.8) monitors power units type AB8, ATP2, ATP24 or an electronic amplifier for a proportional pressure limiter of an hydraulic power unit, customer supply the reference speed signal.
- **CRD-RC**: to the regulation board is connected a deceleration control board, fully independant from the regulation board (power supply. speed signal. scale and command).

Fig. 1

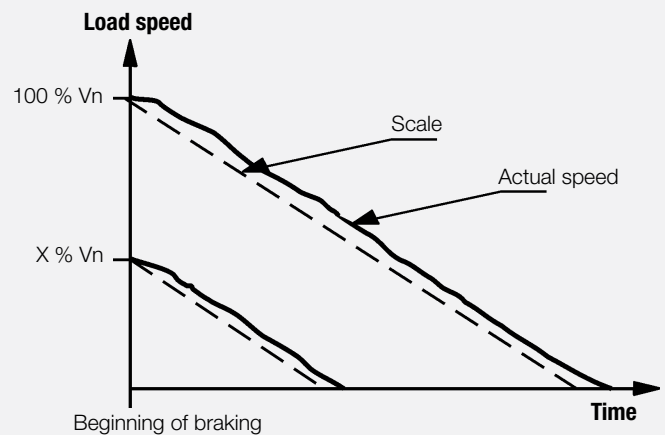
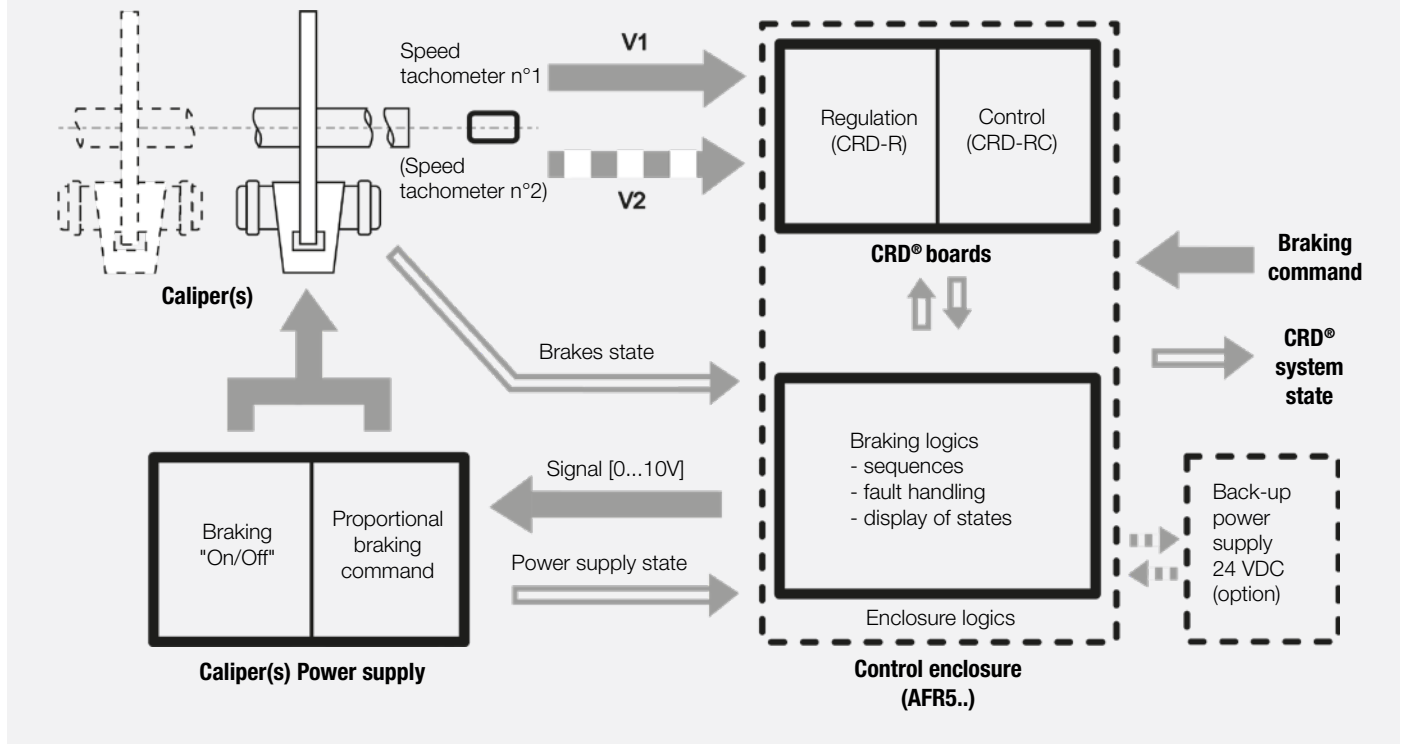

Fig. 2



### DISC BRAKE - CONSTANT DECELERATION CRD MODULE

Revision number: M08950-01-C

Revision date: 03.06.2015

#### 3 - OPERATION

##### 3-1 Deceleration regulation

CRD® module allows a deceleration regulation according to a scale at the time of a normal or an emergency braking.

##### 3-2 Deceleration control (CRD-RC version only)

Using a second speed sensor connected to "deceleration fault control board" insures that first board operating is correct (detected mis-functioning: braking is too low or too high. mechanical shaft or gear box failure. failure of a speed sensor or damaged wires).

##### 3-3 "S" curve deceleration

CRD® module allows user to select JERKS at begining and/or end of braking; duration of these "S" curves may be adjusted.

##### 3-4 Lowering

CRD® module provides lowering function (load is let down on command after a full successful braking. for security purpose) to X % of nominal speed (setting between 5 and 20%), at constant speed, or at variable speed (operator controlled auto "0" recentering joystick).

Fig. 3

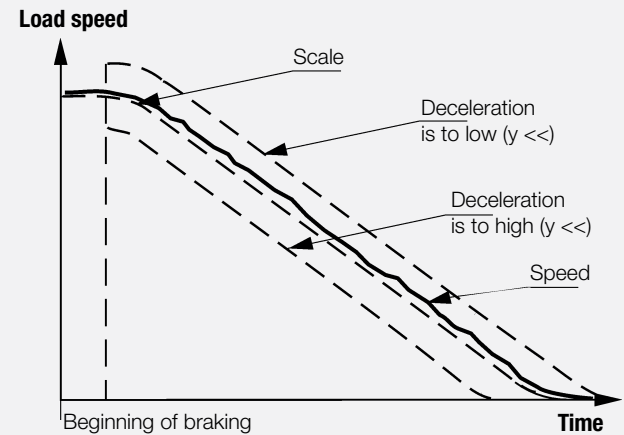

Fig. 4

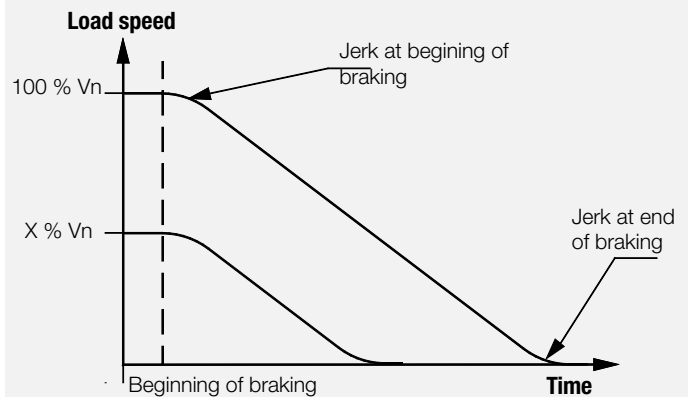
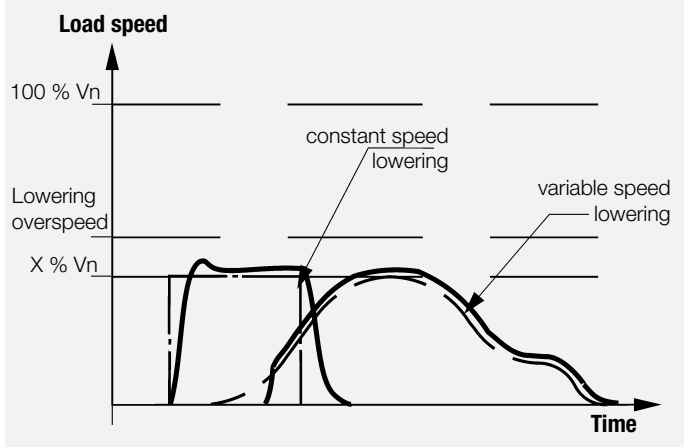

Fig. 5



## Safety Systems

# DISC BRAKE - CONSTANT DECELERATION CRD MODULE

Revision number: M08950-01-C

Revision date: 03.06.2015

### 4 - PHYSICAL CHARACTERISTICS OF CRD® MODULE

This equipment receives speed signal from the speed sensor(s) and delivers an output signal (0...10V.) while following an internal or external speed scale. board(s) are:

#### 4-1 In separate casing

- **dimensions:** see fig. 6a (CRD-R) & fig. 6b (CRD-RC); Location - enclosure must be installed onto a vertical support - will allow natural ventilation.
- **Environment:** Ambient temperature: -10°C to +50°C.
- The IP 559 casing is equipped with 5 cable glands PG 11 (CRD-R) or 5 cable glands PG 11 and 4 cable glands PG 9 (CRD-RC).
- **Mains power supply:** 230V AC  $\pm 10\%$  50/60Hz or 24V DC (20 to 30 V DC). Power consumption: 5W maxi. per board.

#### 4-2 Inside control casing

- **dimensions:** see fig. 7a (CRD-R) & fig. 7b (CRD-RC);
- **Environment:** Ambient temperature: -10°C to +50°C.
- **Mains power supply:** 230V AC  $\pm 10\%$  50/60Hz or 24V DC (20 to 30 V DC). Power consumption: 5W maxi. per board.

### 5 - EQUIPMENT

Necessary equipment for braking will include:

#### 5-1 Brakes

1.2. 4.... electrohydraulic calipers (type **TY5**, **TH** or **SH**) or electromagnetic (type **650E**, **5KE**).

#### 5-2 Electric power supply (case of electromagnetic brakes)

Power supply associated to the brake will be capable of braking regulation (type **AC64-50** associated with **AB8** module).

#### 5-3 Hydraulic power pack (hydraulic brakes SH or TH type)

Hydraulic power pack will be capable of regulating deceleration (for example: **STE 210 Y5** with proportional pressure limiter). An alternate motor may optionally be added (24 V. DC) to the main motor supplied by Mains, allowing deceleration regulation in case of Mains failure (**M2** option).

#### 5-4 AFR5 Control casing (SH and TH brakes)

Initiate deceleration regulation, controls its logics and faults to keep all electrical components secure.

#### 5-5 Back-up power supply (M2 option)

In case of mains failure, the need for deceleration regulation may involve installing a back-up power supply - Stromag France or customer supplied.

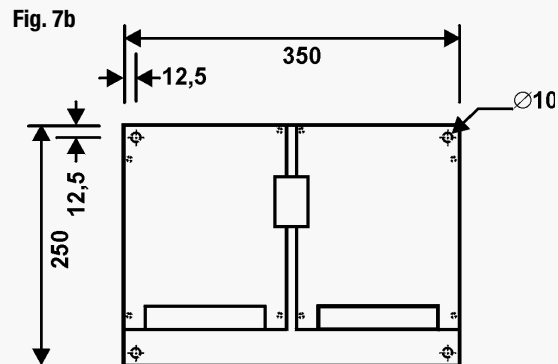
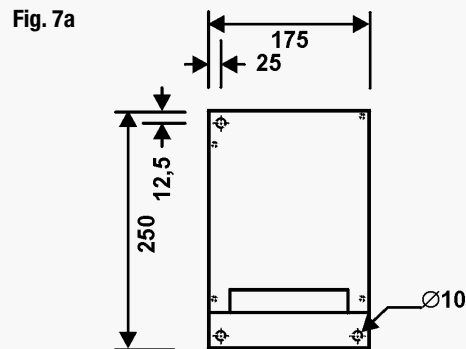
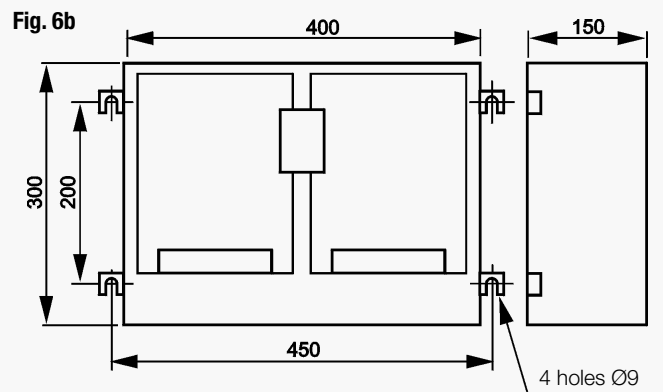
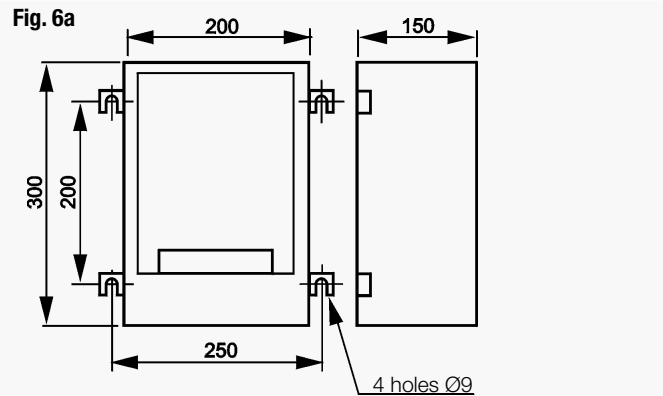



### DISC BRAKE - CONSTANT DECELERATION CRD MODULE

Revision number: M08950-01-C

Revision date: 03.06.2015

Fig. 8

DECELERATION REGULATION BOARD

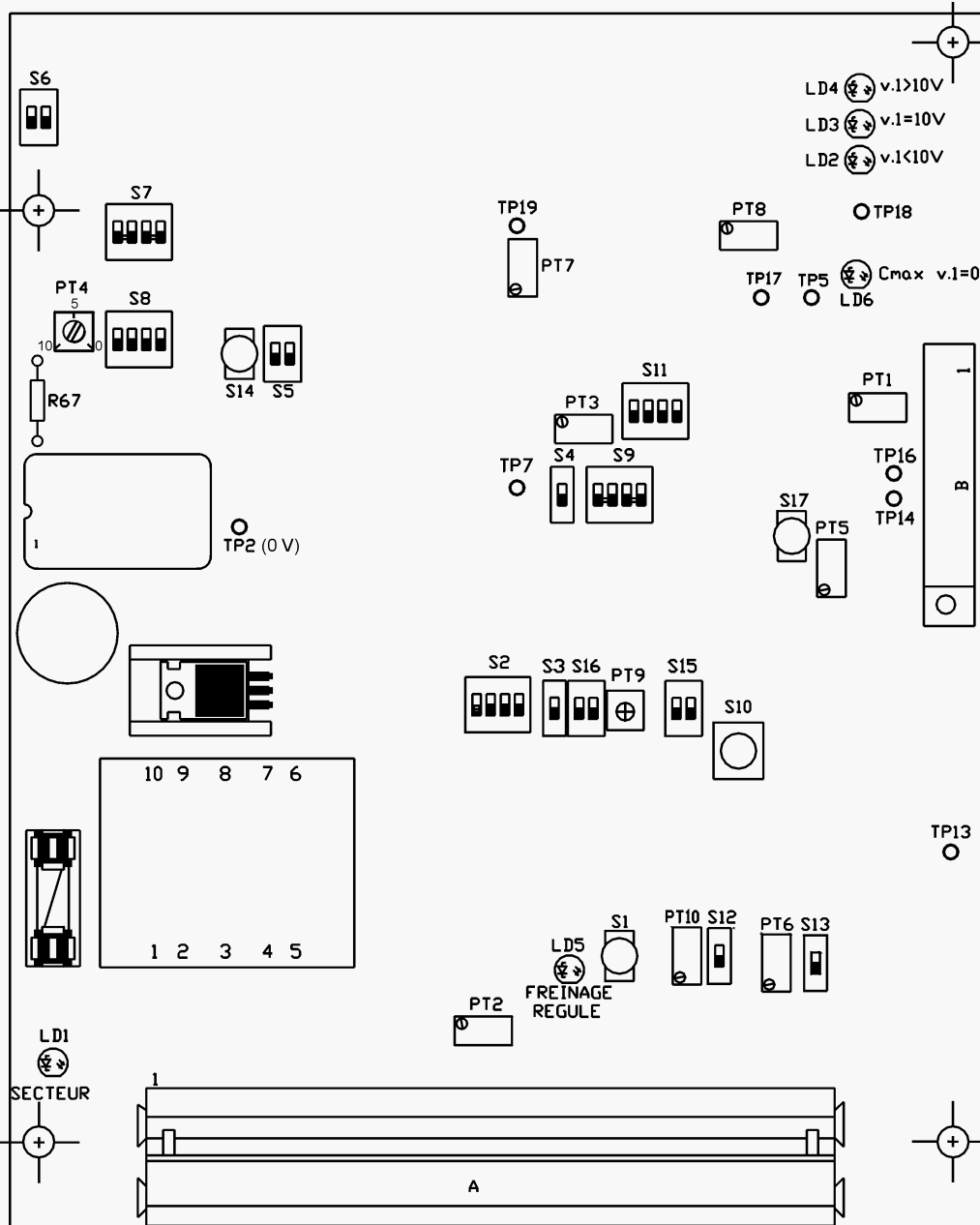

#### Switches list

- S1: ramp simulation (green push button)
- S2: speed signal frequency range
- S3: speed signal selection: voltage or frequency
- S4: selection of speed signal amplification
- S5: speed signal filtration
- S6: "S" curve/jerk at beginning of ramp
- S7: "S" curve/jerk at end of ramp
- S8: ramp time
- S9: regulation amplification = function P
- S10: TP16 output manual command to 10V. (black push button)
- S11: regulation filtration = fonction I
- S12: AB8 or ATP output selection
- S13: internal/external lowering potentiometer selection
- S14: fault simulation (red push button)
- S15: regulation filtration = fonction I
- S16: regulation derivative : fonction D
- S17: TP16 output manual command to 0.3V (+ action on S10) (black push button)

#### Potentiometers list

- PT1: (factory setting)
- PT2: speed signal adjustment
- PT3: speed signal amplification
- PT4: ramp time fine tuning
- PT5: "bias" lock
- PT6: internal potentiometer for "external scale"
- PT7: brake running-up (forecast of hydraulical delay)
- PT8: speed is nil setting
- PT9: fonction D ajustment
- PT10: ajustment of the maximum value of the external potentiometer

# SIME Brakes Industrial Braking Systems

## Safety Systems

### DISC BRAKE - SPEED REGULATION CRV MODULE

Revision number: M08955-01-B

Revision date: 03.06.2015

#### 1 - PRESENTATION

Speed regulation with **CRV**, in combination with brakes type **5KE**, **650E**, **TY5**, **TH** and **SH**, provides a regulated speed braking whatever the load quantity and load specificity, pulling or resisting.

Use: lowering, speed regulation.

Applications: cableways, chairlifts, funiculars, lifts, belt conveyors, transporters, cranes, etc...

#### 2 - PRINCIPLE

**CRV** system (fig. 1) consists of:

- 1 or more brakes (progressive brakes type **5KE**, **650E**, **TY5**, **TH** and **SH**);
- 1 hydraulic pack (**STE210Y5**, **CE8L-RY5**) or 1 electric power supply (AB8, ATP2, ATP24).
- 1 (or more) speed sensors (tachometric dynamo..).
- 1 **CRV** module, it may be integrated into an AFR5 enclosure supplied by Stromag France.

Two **CRV®** versions exist:

- **CRV-R**: a speed regulation board (fig. 8) monitors power units type AB8, ATP2, ATP24 or an electronic amplifier for a proportional pressure limiter of an hydraulic power unit ; customer supply the reference speed signal.
- **CRV-RC**: to the regulation board is connected a speed control board, fully independant from the regulation board (power supply, speed signal, scale and command).

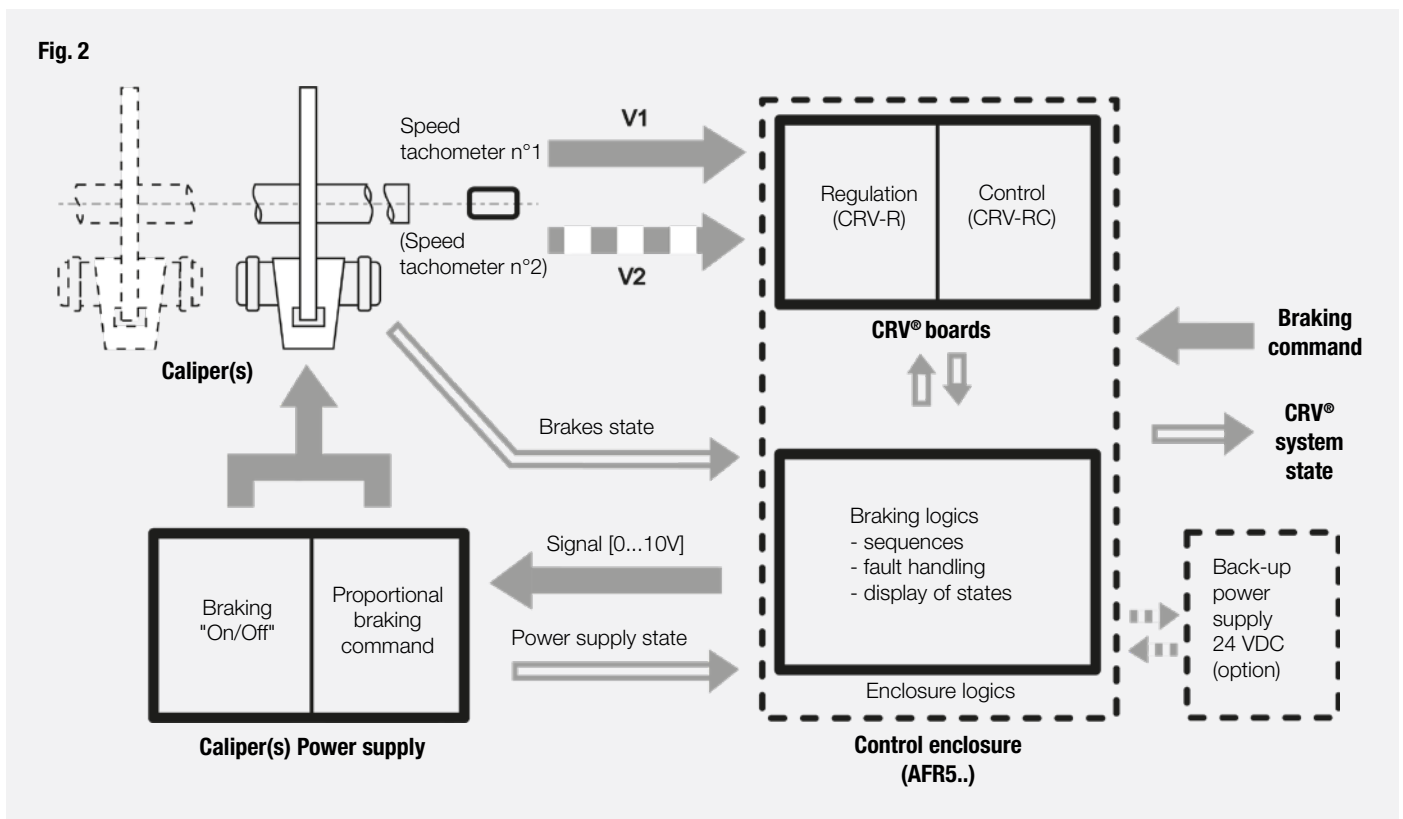

### DISC BRAKE - SPEED REGULATION CRV MODULE

Revision number: M08955-01-B

Revision date: 03.06.2015

#### 3 - OPERATION

##### 3-1 Lowering - fig.2

CRV module allows choosing a lowering (regulated load lowering after stop. for security purpose) at X % of nominal speed, (setting between 5 and 20%), at constant speed, or at variable speed (potentiometer with automatic "0" restoring adjusted by operator).

##### 3-2 Speed regulation - fig.3

CRV module allows a speed regulation set at X% of nominal speed (constant speed, factory set between 5 and 100% of nominal speed), failure of a speed sensor or damaged wires).

##### 3-3 Speed control (CRV-RC only)

Using an additional speed sensor connected to "speed control" board allows a monitoring of the regulation (detected anomalies: speed too high or too low, mechanical breakdown of shafts or gearbox, speed sensor anomaly or damaged wiring).

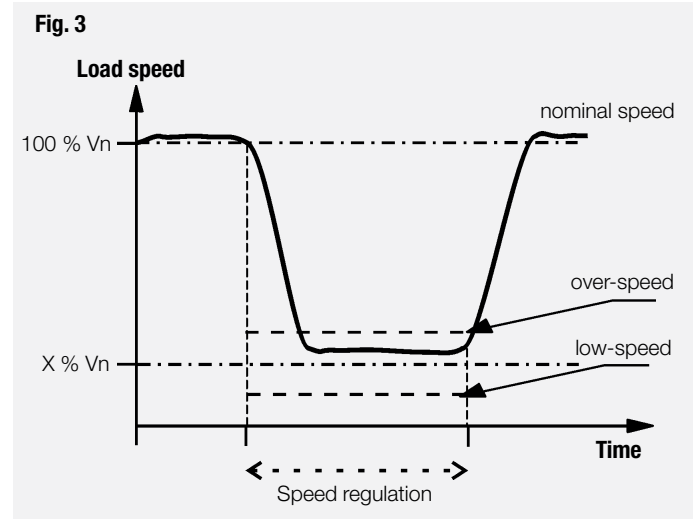
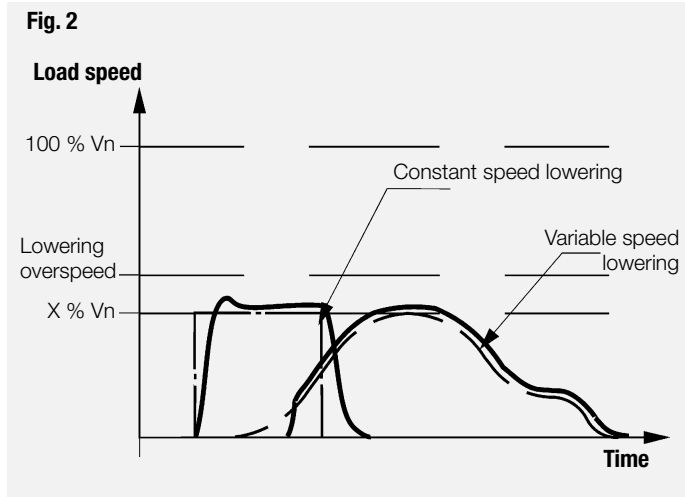

## Safety Systems

# DISC BRAKE - SPEED REGULATION CRV MODULE

Revision number: M08955-01-B

Revision date: 03.06.2015

### 4 - PHYSICAL CHARACTERISTICS OF CRV® MODULE

This equipment receives speed signal from the speed sensor(s) and delivers an output signal (0...10V) while following an internal or external speed scale. board(s) are:

#### 4-1 In separate casing

- **dimensions:** see fig. 4 (CRV-R) & fig. 5 (CRV-RC); Location - enclosure must be installed onto a vertical support - will allow natural ventilation.
- **Environment:** Ambient temperature: -10°C to +50°C.
- The IP 559 casing is equipped with 5 cable glands PG 11 (CRV-R) or 5 cable glands PG 11 and 4 cable glands PG 9 (CRV-RC).
- **Mains power supply:** 230V AC  $\pm 10\%$  50/60Hz or 24V DC (20 to 30 V DC). Power consumption: 5W maxi. per board.

#### 4-2 Inside control casing

- **dimensions:** see fig. 6 (CRV-R) & fig. 7 (CRV-RC);
- **Environment:** Ambient temperature: -10°C to +50°C.
- **Mains power supply:** 230V AC  $\pm 10\%$  50/60Hz or 24V DC (20 to 30 V DC). Power consumption: 5W maxi. per board.

### 5 - EQUIPMENT

Necessary equipment for braking will include:

#### 5-1 Brakes

1.2. 4... electrohydraulic calipers (type **TY5. TH** or **SH**) or electromagnetic (type **650E. 5KE**).

#### 5-2 Electric power supply (case of electromagnetic brakes)

Power supply associated to the brake will be capable of braking regulation (type **AC64-50** associated with **AB8** module).

#### 5-3 Hydraulic power pack (hydraulic brakes SH or TH type)

Hydraulic power pack will be capable of regulating deceleration (for example: **STE 210 Y5** or **CE8L-Y5** with proportional pressure limiter). On the **STE210Y5**, to the main motor supplied by Mains, an alternate motor may optionally be added (24 V. DC) to the main motor supplied by Mains, allowing speed regulation in case of Mains failure (**M2** option).

#### 5-4 AFR5 Control casing (SH and TH brakes)

Initiate speed regulation, controls its logics and faults to keep all electrical components secure.

#### 5-5 Back-up power supply (M2 option)

In case of mains failure, the need for speed regulation may involve installing a back-up power supply - Stromag France or customer supplied.

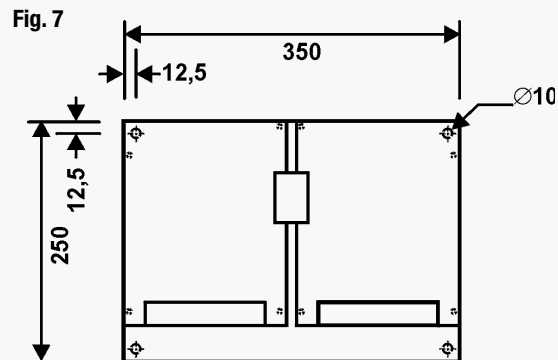
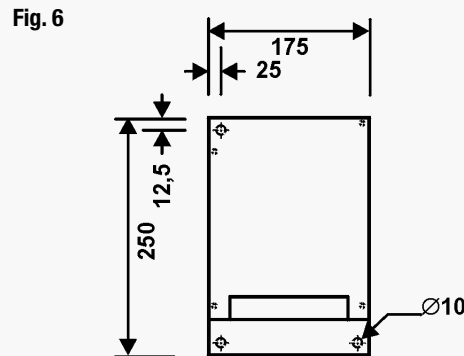
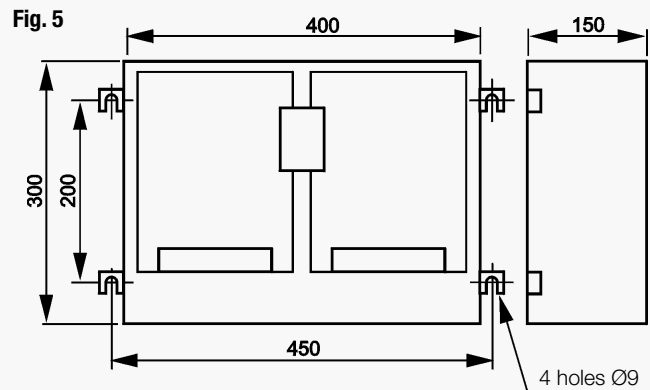
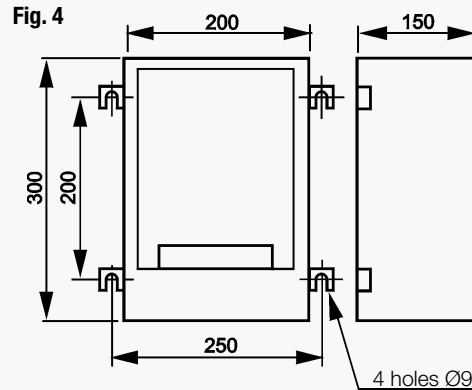

### DISC BRAKE - SPEED REGULATION CRV MODULE

Revision number: M08955-01-B

Revision date: 03.06.2015

Fig. 8

SPEED REGULATION BOARD

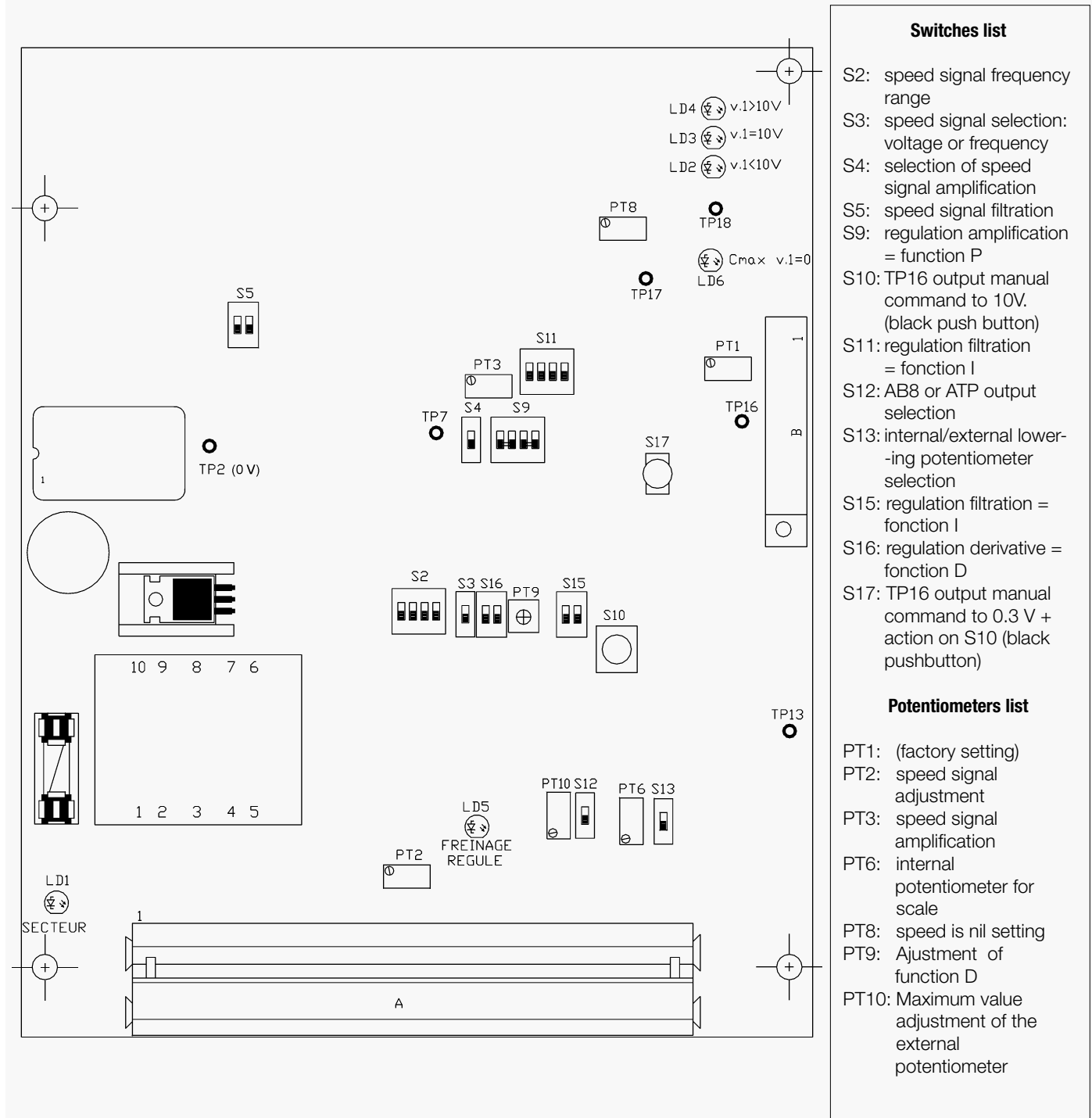

# SIME Brakes Industrial Braking Systems

## Safety Systems

### DISC BRAKE - AFR5 CONTROL ENCLOSURES

Revision number: M10105-01-E

Revision date: 03.06.2015

AFR5 control enclosures are designed for controlling and monitoring regulated braking systems.

They allow different braking modes :

- Constant deceleration (**CRD®** module)  
ex. : Cableway : Pic du Midi (Bagnères de Bigorre)
- Constant deceleration and speed regulation (**CRD®** module)  
ex. : Passengers elevator : Eiffel Tower in Paris
- Normal operation (AoN) and speed regulation for load lowering (**CRV®** module)  
ex. : Steel industry ladle crane : HKM (Deutschland)

They can be designed to ensure a safety performance level up to PL d to the braking system.

They can includes :

- an Ethernet line towards the customer PLC,
- the braking management in case of power supply loss or regulated braking fault,
- the speed monitoring (**SIDEOS One**),
- the control of standby brakes or/and Hydraulic Power Packs to ensure the operation continuity in case of failure of one part of the braking system,
- a Human Machine Interface or Module.



Here is, for example, the diagram of the AFR5-HKM enclosure :  
All or Nothing braking - Load lowering - Performance level PLd - Standby brakes - Data transmission to the customer PLC via ProFibus and secured ProFibus.

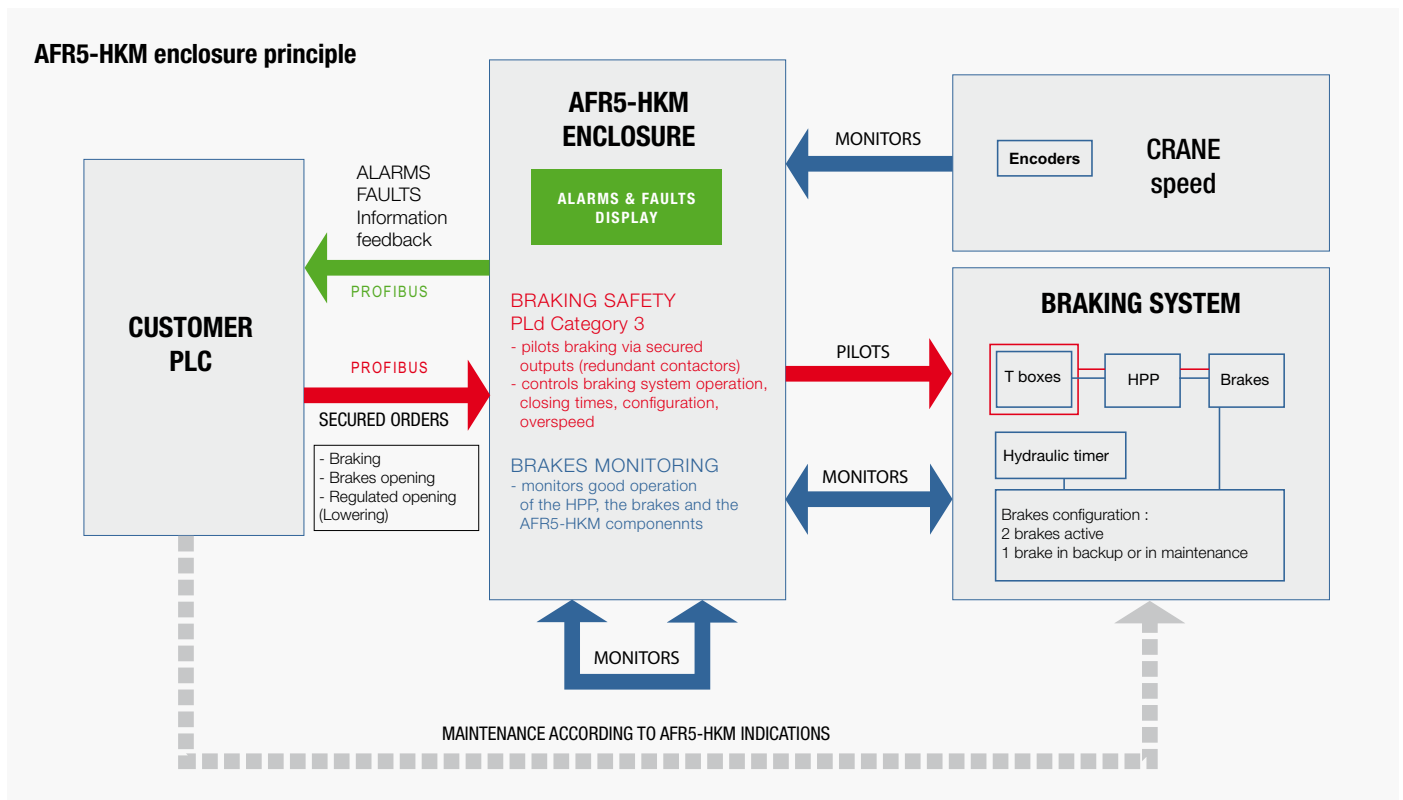

### DISC BRAKE - AFR5 CONTROL ENCLOSURES

Revision number: M10105-01-E

Revision date: 03.06.2015

HKM Braking System monitored and controlled by AFR5-HKM enclosure

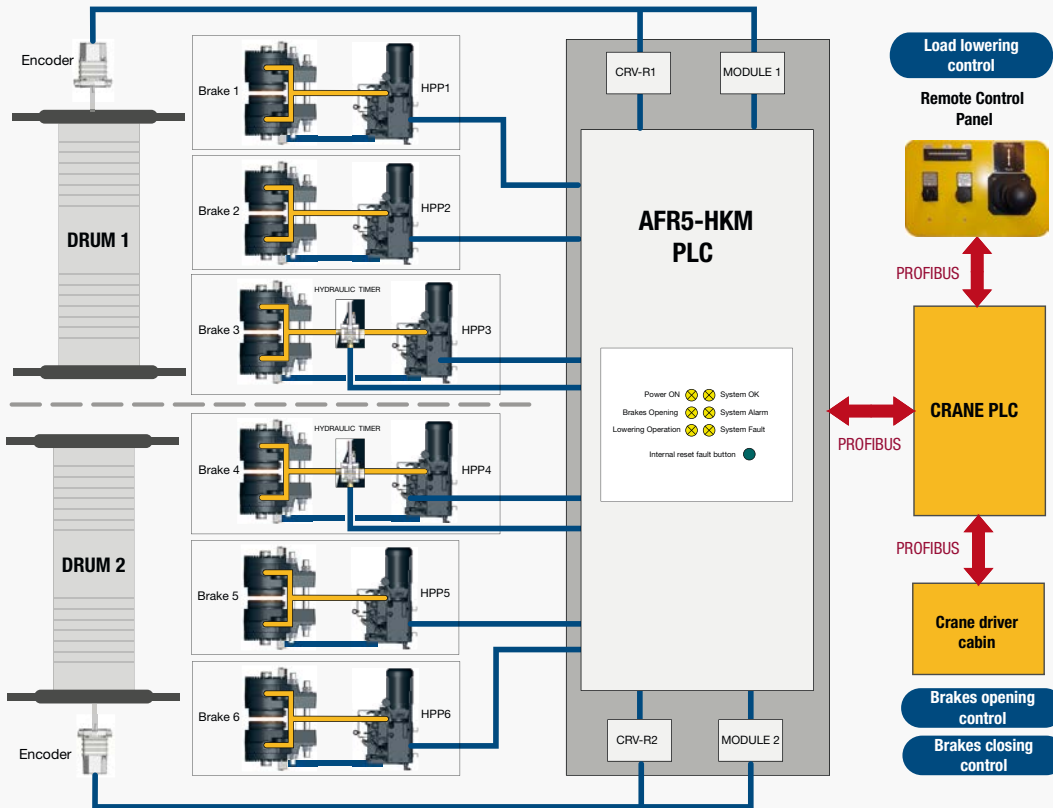
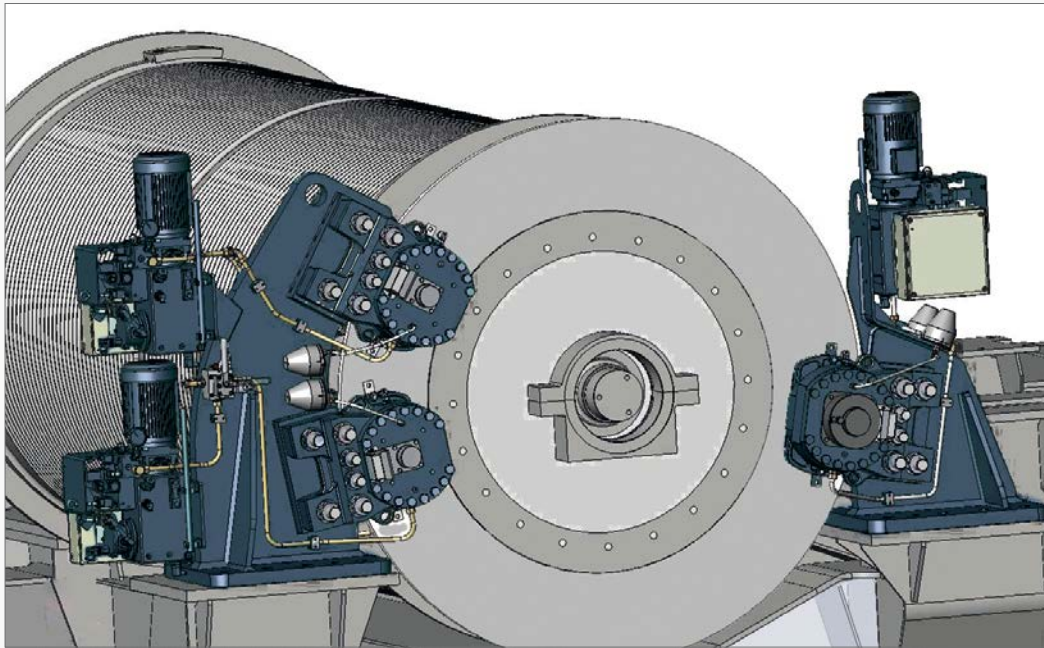

# SIME Brakes Industrial Braking Systems

## Discs & Drums

### DISCS & DRUMS

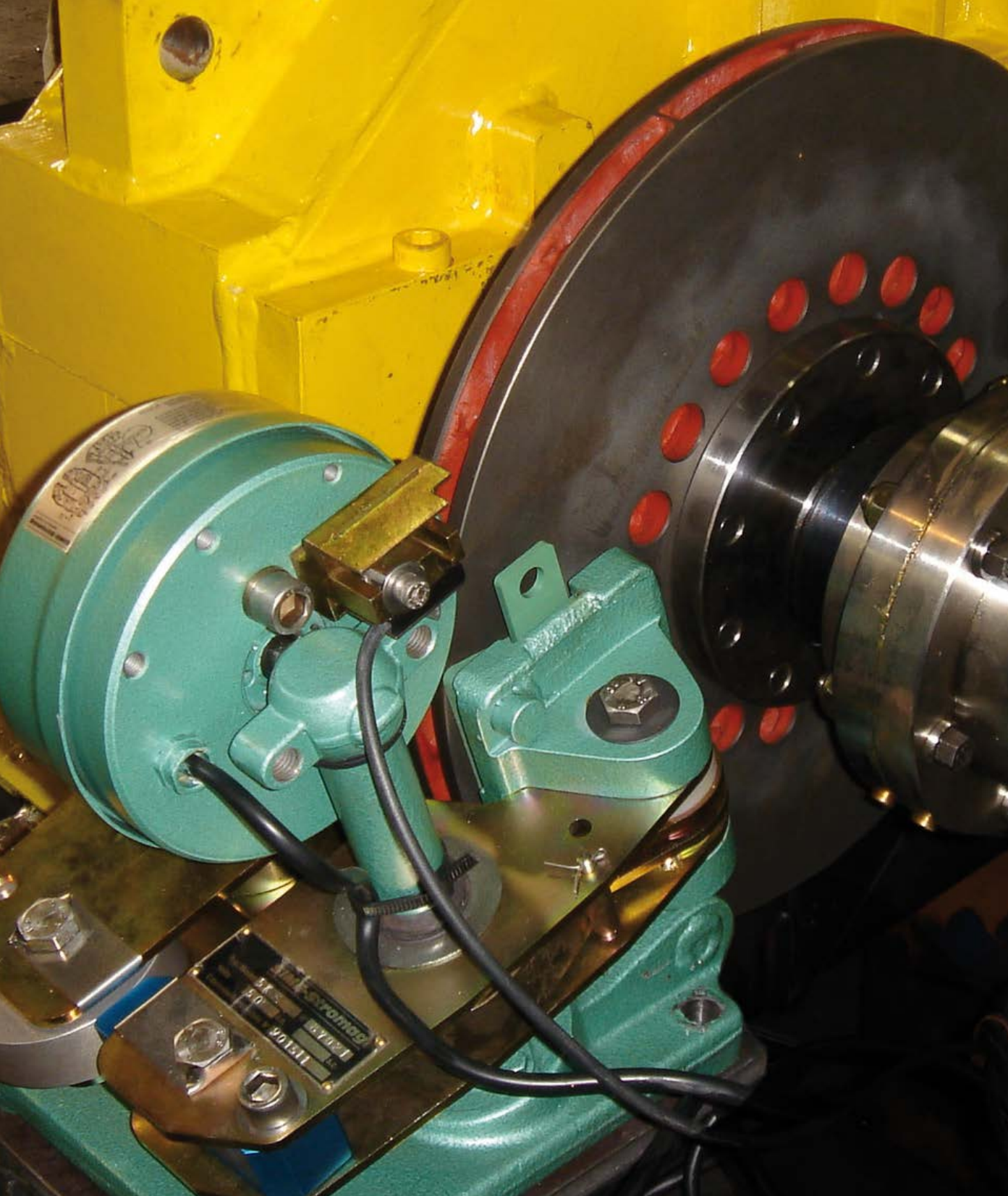



### MAIN CHARACTERISTICS

- DISCS ARE AVAILABLE ALONE OR WITH HUBS
- ALL DISCS CAN BE ASSOCIATED WITH THE DIFFERENT TYPES OF FLEXIBLE COUPLINGS
- DESIGNED TO RUN AT PERMANENT TEMPERATURE OF 200°C
- DRUMS ARE AVAILABLE ALONE OR WITH HUB
- DRUMS ARE ASSOCIATED WITH THE SIME BRAKES TYPES FNS AND SDB STANDARD DIN 15435



#### MONOBLOC & SOLID DISCS

- for low energy applications.



#### AUTO-VENTILATED DISCS

- comply with NF S 472 B standard.
- for high frequency and heavy duty braking cycles.
- high capacity of energy dissipation.

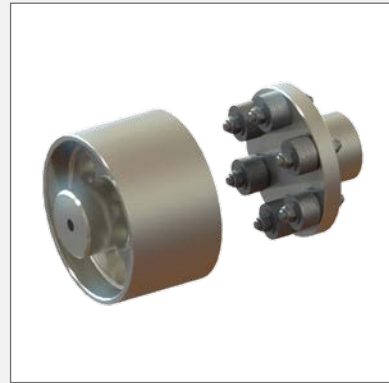

#### DRUMS

- flanged hub fitted with rubber bushes.
- uniform distribution of loads. even in case of misalignment.
- reduction of resonance effects at critical velocity.

#### Discs thicknesses and diameters

DISCS	Diameter →	Ø 175	Ø 220	Ø 260	Ø 315	Ø 355	Ø 395	Ø 445	Ø 495	Ø 550	Ø 625	Ø 705	Ø 795	Ø 995
SOLID	Th. 15 mm													
MONOBLOC	Th. 30 mm													
VENTILATED	Th. 30 mm													
	Th. 42 mm													

#### Drums widths and diameters

DRUMS	Diameter	Ø 160	Ø 200	Ø 250	Ø 315	Ø 400	Ø 500	Ø 630	Ø 710
	Width	60	75	95	118	150	190	236	265

## Discs & Drums

### DISC BRAKE - DISCS

Revision number: T08020-01-F

Revision date: 27.07.2017

#### DISCS OF BRAKES CHARACTERISTICS

##### 1 - Dimensions

Refer to leaflets "Technical data and dimensions" relevant to the type of disc used.

For a new disc, the tolerance of the thickness dimension is :

±0.15

##### 2 - Materials

Ventilated discs : Cast iron type EN-GJS-400-18-LT ou EN-GJS-350-22

Solid discs : Steel S355 K2

Hubs : Steel 25/34/42CrMo4

##### 3 - Surface quality of the contact zone with lining (table 1)

Friction surface : Ra 1.6 to 3.2 in all directions  
Centring zone : Idem

##### 4 - Balancing

Only bare discs (except monoblocs).

Discs are balanced in "static" quality G6.3 :

- at the speed of 1800 rpm for discs  $\varnothing \leq 550$  mm.
- at the maximum speed indicated in the "technical data" leaflets for discs  $\varnothing > 550$  mm

The correction area is placed between the hub and the little diameter of the friction surface (see table 1).

For balancing with hub, with half-coupling or at high speed, consult us.

Table 1 - Dimensions of the friction surface

EXTERNAL DIAMETER	INNER DIAMETER				
	Thickness 15	Thickness 30			Thickness 42
	Monobloc disc	Monobloc disc	Ventilated disc	Solid disc	Ventilated disc
175	85	---	---	---	---
220	105	90	---	---	---
260	132	136	---	---	---
315	130	180	165	130	---
355	---	---	206	155	---
395	157	---	246	246	---
445	207	---	216	185	---
495	300	---	256	256	---
550	350	---	325	314	---
625	430	---	387	387	370
705	---	---	462	462	---
795	---	---	542	542	542
995	---	---	---	600	745

### DISC BRAKE - DISCS

Revision number: T08020-01-F

Revision date: 27.07.2017

#### 5 - Wear limit before the replacement of the disc

##### DANGER !

In case of an excessive wear of the disc the brake can operate out of its nominal range of setting and consequently lead to a loss of braking force.



The table 2 sums up the discs minimum thicknesses as before their replacement.

**Table 2**

Type of disc	Thickness unused (± 0.15) mm	Minimum thickness before replacement mm	Minimum web before replacement mm
Monobloc discs	30	27	6.5
Ventilated discs	30	27	6
	42	39	with core of 16 : 11 with core of 23 : 8
Solid discs	15	13	
	30	27	
	42	39	

# SIME Brakes Industrial Braking Systems

## Discs & Drums

### DISC BRAKE - MONOBLOC DISCS

Revision number: T02160-01-A

Revision date: 02.05.2003

Diametres: 220, 260 and 315 mm.  
Thickness: 30 mm.

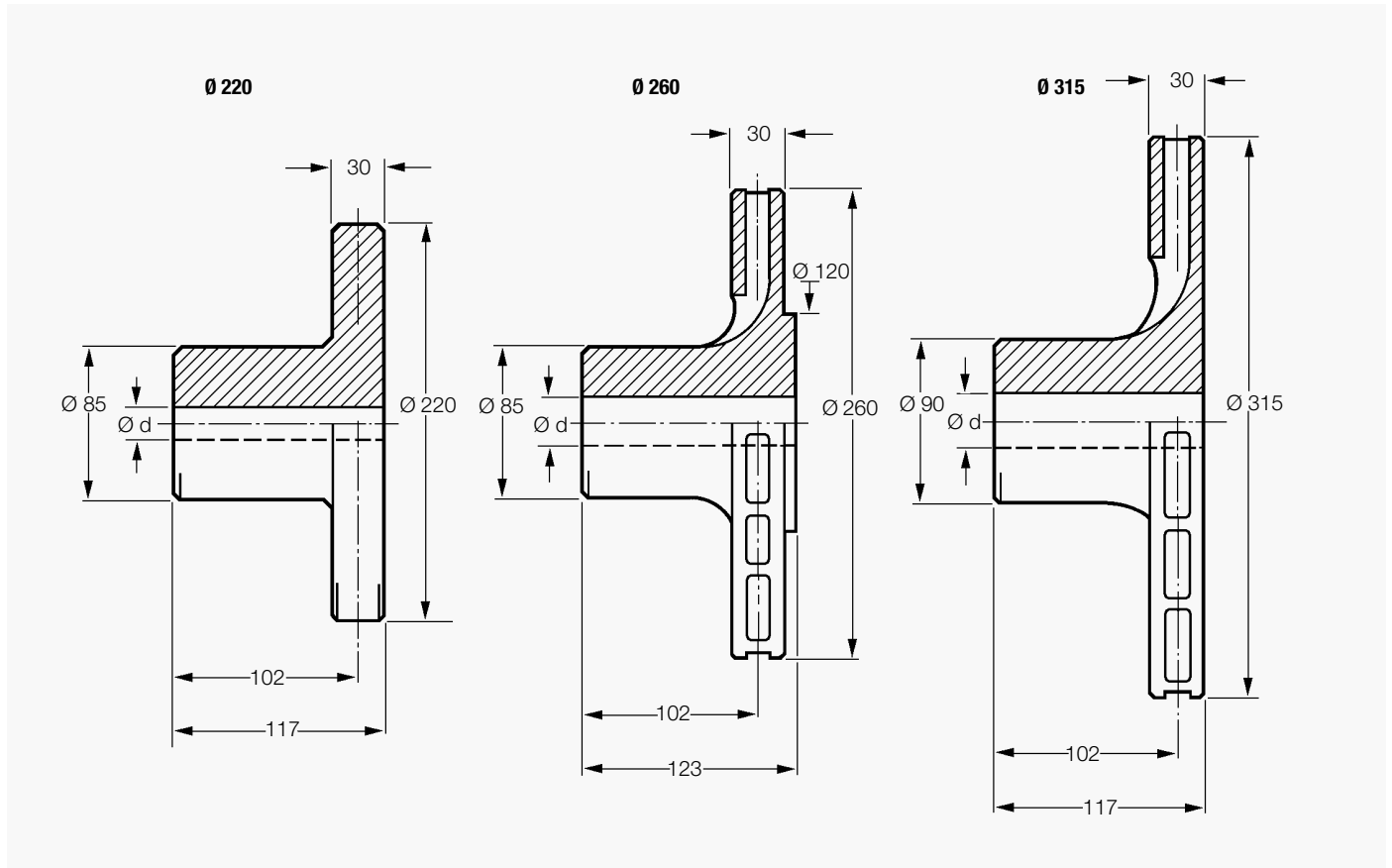

Designation		Ø	220 M 30	260 M 30	315 M30
<b>J</b>		kg/m <sup>2</sup>	0.055	0.070	0.14
Weight		kg	11.2	10	12
Maximum speed		rpm	4300	3600	3000
d max.	keyed	mm	55	55	60
	shrink fit	mm	55	55	60

### DISC BRAKE - SOLID DISCS

Revision number: T02100-01-A

Revision date: 01.03.2001

Thickness: 15 mm

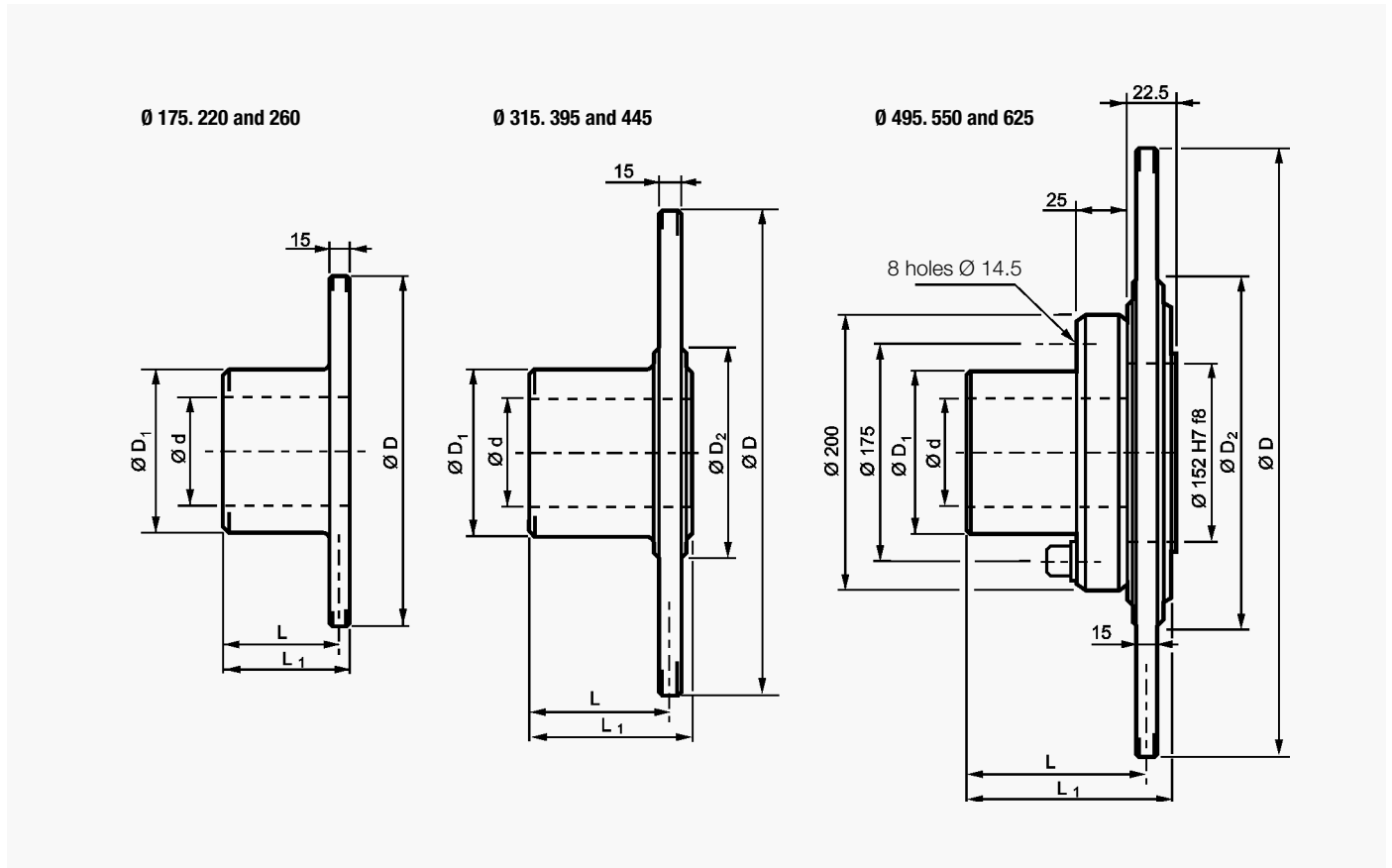

Designation		175 P 15	220 P 15	260 P 15	315 P 15	395 P 15	445 P 15	495 P 15	550 P 15	625 P 15
J	kg/m <sup>2</sup>	0.01	0.03	0.06	0.13	0.30	0.48	0.77	1.16	1.93
Weight	kg	4	7.6	13	18	24	28	43	49	59
Maximum speed	tr/mn	5000	4300	3600	3000	2400	2100	1900	1800	1500
D	mm	175	220	260	315	395	445	495	550	625
D <sub>1</sub>	mm	75	95	120	120	120	120	150	150	150
D <sub>2</sub>	mm	-	-	-	130	200	207	257	312	387
L	mm	55	65	85	102	102	102	135	135	135
L <sub>1</sub>	mm	62.5	72.5	92.5	117	117	117	150	150	150
d max.	keyed	mm	0-40	0-55	0-75	0-75	0-75	0-100	0-100	0-100
	shrink fit	mm	40	65	80	80	80	100	100	100

# SIME Brakes Industrial Braking Systems

## Discs & Drums

### DISC BRAKE - VENTILATED AND SOLID DISCS

Revision number: T02220-01-B

Revision date: 26.11.2010

Diameter from 315 to 995 mm for solid discs P30  
 Diameter from 315 to 795 mm for ventilated discs V30  
 Thickness : 30mm

Material of discs and hubs  
 Protection of discs  
 Balancing  
 see leaflet T08020-01  
**Note** : hubs are not balanced.

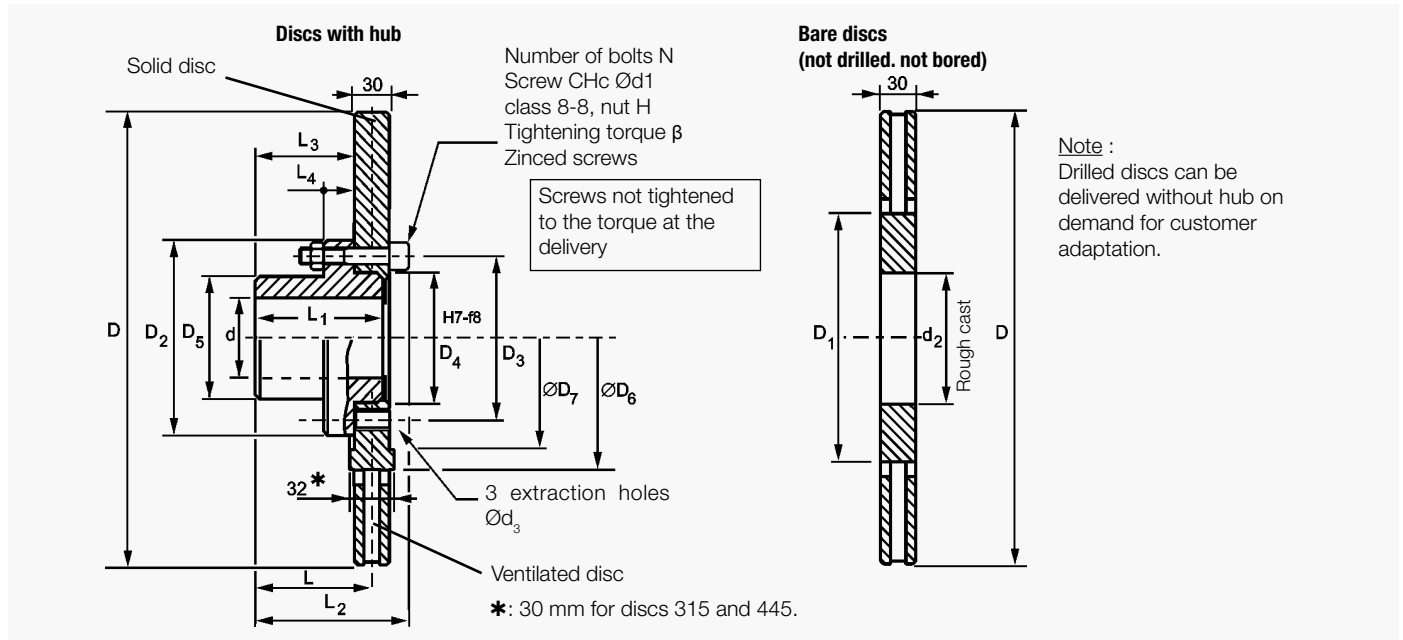

Designation	Type	315		355		395		445		495	
		P30	V30	P30	V30	P30	V30	P30	V30	P30	V30
J Disc + hub	kg.m <sup>2</sup>	0.234	0.148	0.379	0.243	0.588	0.352	0.94	0.581	1.492	0.968
	Bare disc	0.225	0.139	0.362	0.226	0.56	0.324	0.896	0.537	1.367	0.843
Weight	Disc + hub	21.7	14.7	27.5	18.5	34	23	46.5	31.5	65	47
	Bare disc	17	10	21	12	27	16	34	19	41	23
Maximum speed	rpm	3000		2700		2400		2100		1900	
Maximum braking torque ■	N.m	1720		2987		4594		8798		14321	
D	mm	315		355		395		445		495	
D1	mm	139		172		177		184		230	
D2	mm	125		145		165		175		220	
D3	mm	105		125		140		146		190	
D4	mm	85		105		115		120		160	
D5	mm	80		95		105		110		150	
D6	mm	-	-	-	173	-	246	-	-	-	256
D7	mm	-	-	-	151	-	171	-	-	-	226
L	mm	102		102		102		135		135	
L1	mm	107		107		107		140		140	
L2	mm	127		129		131		166		168	
L3	mm	87		87		87		120		120	
L4	mm	28		28		28		30		38	
Bore	keyed	50		60		70		75		100	
	maxi. d ** shrink fit	50		60		70		75		100	
d1	mm	M10		M12		M14		M16		M18	
d2	mm	76.5		96.5		106.5		111.5		151.5	
d3	mm	M10		M12		M14		M16		M18	
N		9		9		9		12		12	
Tightening torque β	N.m	49		86		135		210		290	

■ Maximum braking torque allowed by the bolts of disc and hub assembling.



**ATTENTION !**  
 The torque transmissible by shaft and keying must be checked.

\*\* Tolerance on d and keying on Customer demand.

### DISC BRAKE - VENTILATED AND SOLID DISCS

Revision number: T02220-01-B

Revision date: 26.11.2010

Diameter from 315 to 995 mm for solid discs P30  
 Diameter from 315 to 795 mm for ventilated discs V30  
 Thickness : 30mm

Material of discs and hubs  
 Protection of discs  
 Balancing  
 see leaflet T08020-01  
**Note** : hubs are not balanced.

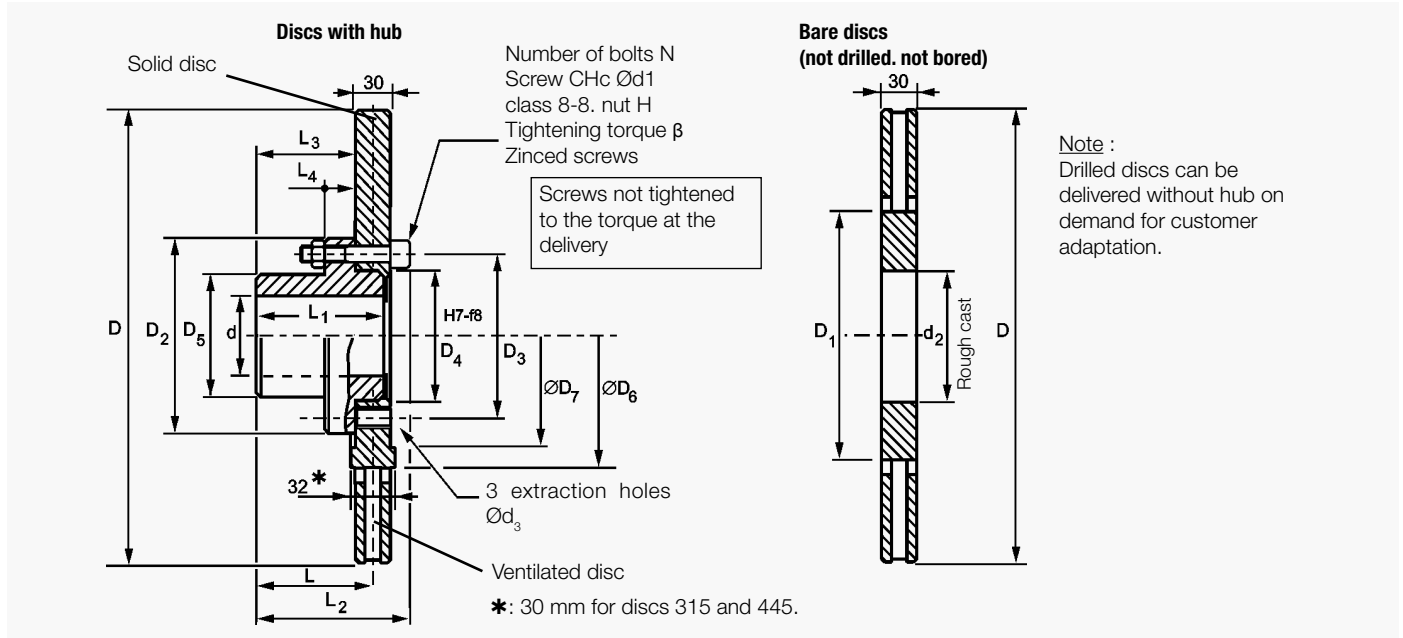

Designation	Type	550		625		705		795		995	
		P30	V30	P30	V30	P30	V30	P30	V30	P30	
J	Disc + hub	kg.m <sup>2</sup>	2.22	1.28	3.676	2.23	5.99	3.76	9.72	6.14	23.86
	Bare disc	kg.m <sup>2</sup>	2.09	1.15	3.506	2.06	5.69	3.46	9.23	5.65	22.51
Weight	Disc + hub	kg	76	53	87.5	60.5	105	72	175.5	135.5	243
	Bare disc	kg	52	29	68	41	86	53	110	70	170
Maximum speed	rpm	1800		1500		1300		1200		900	
Maximum braking torque ■	N.m	14321		19915		27905		36384		73897	
D	mm	550		625		705		795		995	
D1	mm	275		343		418		498		-	
D2	mm	220		235		265		300		380	
D3	mm	190		205		230		260		330	
D4	mm	160		170		195		220		280	
D5	mm	150		150		180		210		260	
D6	mm	-	314	-	387	-	462	-	542	-	
D7	mm	-	226	-	246	-	271	-	310	-	
L	mm	135		135		135		135		135	
L1	mm	140		140		140		140		140	
L2	mm	168		170		172		174		174	
L3	mm	120		120		120		120		120	
L4	mm	38		38		40		40		40	
Bore	mm	100		100		125		140		180	
maxi. d **	mm	100		100		125		140		180	
d1	mm	M18		M20		M22		M24		M30	
d2	mm	151.5		161.5		185.5		211.5		211.5	
d3	mm	M18		M20		M22		M24		M30	
N		12		12		12		12		12	
Tightening torque β	N.m	290		410		550		710		1450	

■ Maximum braking torque allowed by the bolts of disc and hub assembling.



#### ATTENTION !

The torque transmissible by shaft and keying must be checked.

\*\* Tolerance on d and keying on Customer demand.

# SIME Brakes Industrial Braking Systems

## Discs & Drums

### DISC BRAKE - VENTILATED AND SOLID DISCS

Revision number: T02220-01-B

Revision date: 26.11.2010

Diameter 625 - 795 - 995  
Thickness : 42mm

Material of discs and hubs  
Protection of discs  
Balancing  
Note : hubs are not balanced.

} see leaflet T08020-01

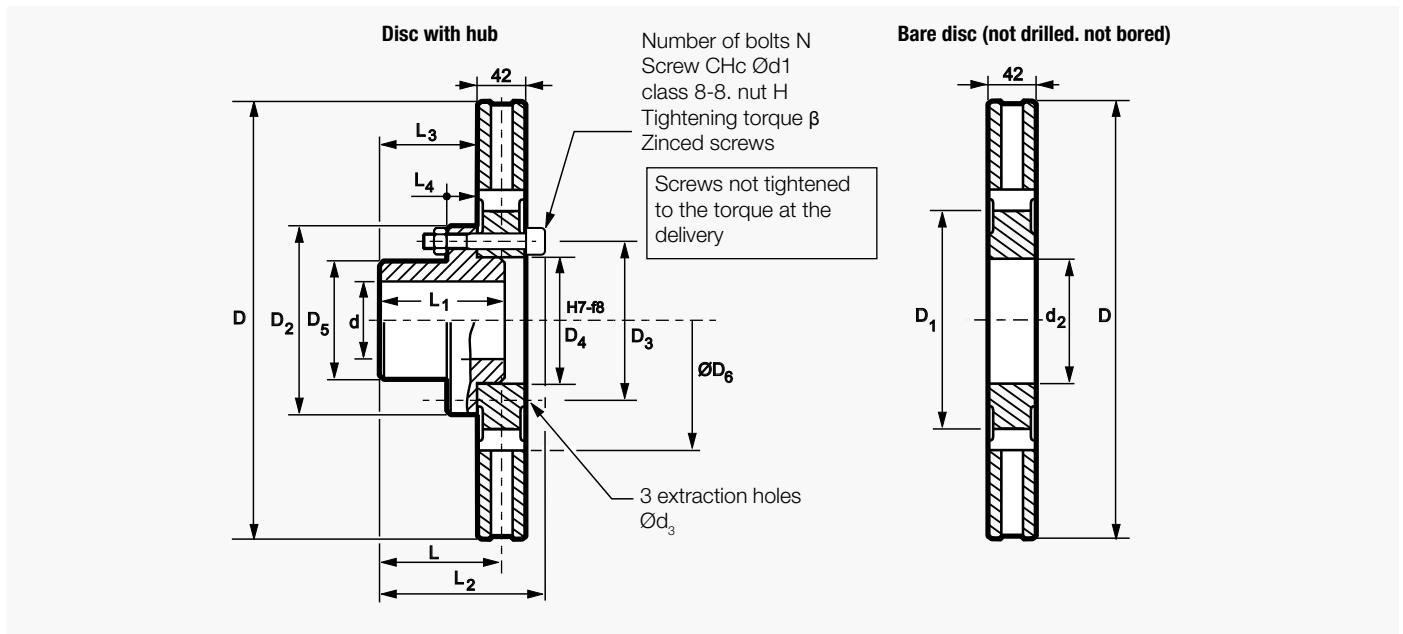

Designation	Type	625V42	795V42	995V42	
J	Disc + hub	kg.m <sup>2</sup>	2.92	7.85	21.3
	Bare disc	kg.m <sup>2</sup>	2,5	6,5	20
Weight	Disc + hub	kg	90	150	250
	Bare disc	kg	45	77	177
Maximum speed		tr/mn	1500	1200	900
Maximul braking torque ■		N.m	36 384	73 897	73 897
D		mm	625	795	995
D1		mm	302	486	694
D2		mm	300	380	380
D3		mm	260	330	330
D4		mm	220	280	280
D5		mm	210	260	260
D6		mm	370	542	745
D7		mm	-	-	-
L		mm	141	141	141
L1		mm	140	140	140
L2		mm	186	186	186
L3		mm	120	120	120
L4		mm	40	40	40
Bore		mm	40-140	40-180	40-180
maxi. d **	keyed	mm	140	180	180
	shrink fit	mm	M24	M30	M30
d1		mm	211	211	211
d2		mm	M24	M30	M30
d3		mm	12	12	12
N			12	12	12
Tightening torque β		N.m	710	1450	1450

■ Maximum braking torque allowed by the bolts of disc and hub assembling.



**ATTENTION !**

The torque transmissible by shaft and keying must be checked.

\*\* Tolerance on d and keying on Customer demand.





# SIME Brakes Industrial Braking Systems

## Discs & Drums

### DISC BRAKE - VENTILATED / SOLID DISCS - LONG HUBS

Revision number: T02222-01-D

Revision date: 07.01.2014

For TDXB and FAV brakes

MLP - diameter from 355 to 995 mm for solid discs P30  
 MLV - diameter from 355 to 795 mm for ventilated discs V30  
 Thickness : 30mm

Material of discs and hubs  
 Protection of discs  
 Balancing

see leaflet T08020-01

Note : hubs are not balanced.

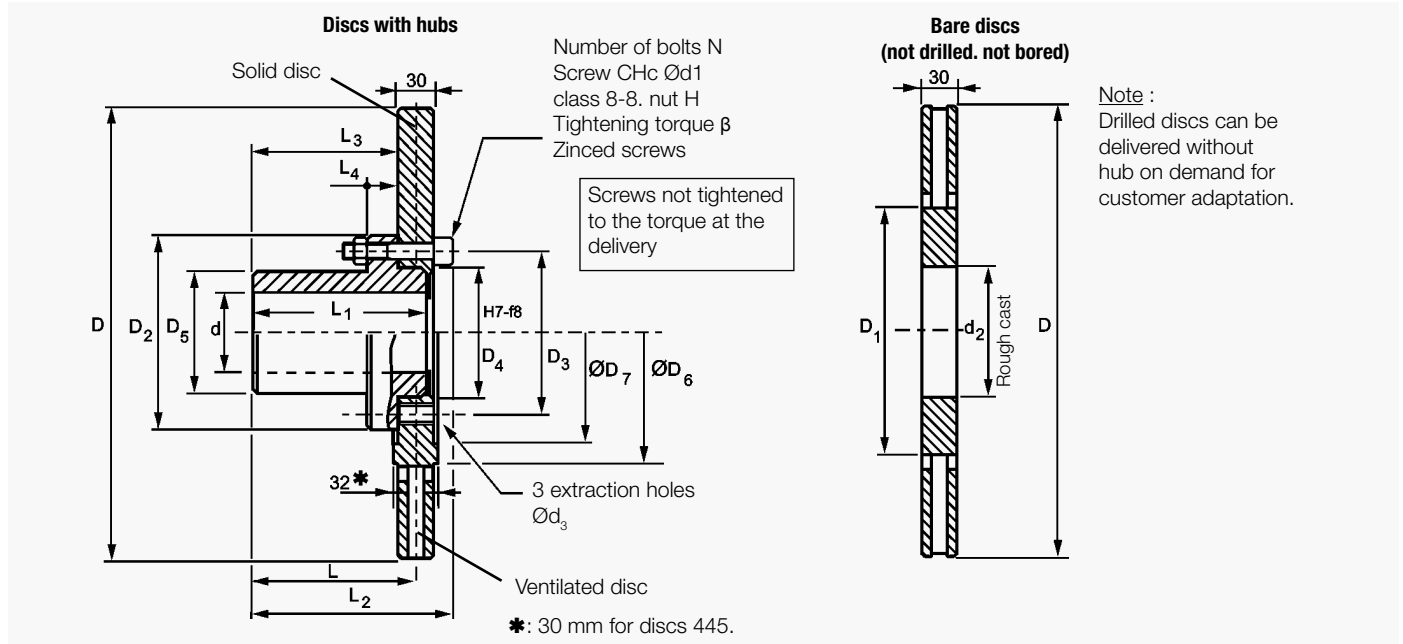

Designation	Type		315		355		395		445		495		550	
			P30	V30	P30	V30	P30	V30	P30	V30	P30	V30	P30	V30
J	Disc + hub	kg.m <sup>2</sup>	0.245	0.159	0.382	0.246	0.593	0.357	0.946	0.587	1.515	0.991	2.243	1.303
	Bare disc	kg.m <sup>2</sup>	0.225	0.139	0.362	0.226	0.56	0.324	0.896	0.537	1.367	0.843	2.09	1.15
Weight	Disc + hub	kg	22.5	15.5	30.5	21.5	37.6	26.6	51	36	73	55	84	61
	Bare disc	kg	17	10	21	12	27	16	34	19	41	23	52	29
Maximum speed	rpm		3000		2700		2400		2100		1900		1800	
Maximum braking torque ■	N.m		1720		2987		4594		8798		14321		14321	
D	mm		315	355	395	445	495	550						
D1	mm		139	172	177	184	230	275						
D2	mm		125	145	165	175	220	220						
D3	mm		105	125	140	146	190	190						
D4	mm		85	105	115	120	160	160						
D5	mm		80	95	105	110	150	150						
D6	mm		-	-	-	173	-	246	-	-	-	256	-	314
D7	mm		-	-	-	151	-	171	-	-	-	226	-	226
L	mm		135	155	155	195	195	195						
L1	mm		140	160	160	200	200	200						
L2	mm		160	182	182	226	228	228						
L3	mm		120	140	140	180	180	180						
L4	mm		28	28	28	30	38	38						
Bore maximum d keyed **	mm		50	60	70	75	100	100						
d1	mm		M10	M12	M14	M16	M18	M18						
d2	mm		76.5	96.5	106.5	111.5	151.5	151.5						
d3	mm		M10	M12	M14	M16	M18	M18						
N			9	9	9	9	12	12						
Tightening torque β	N.m		49	86	135	210	290	290						

■ Maximum braking torque allowed by the bolts of disc and hub assembling.



**ATTENTION !**

The torque transmissible by shaft and keying must be checked.

\*\* Tolerance on d and keying on Customer demand.

### DISC BRAKE - VENTILATED / SOLID DISCS - LONG HUBS

Revision number: T02222-01-D

Revision date: 07.01.2014

**For TDXB and FAV brakes**

MLP - diameter from 355 to 995 mm for solid discs P30  
 MLV - diameter from 355 to 795 mm for ventilated discs V30  
 Thickness : 30mm

Material of discs and hubs  
 Protection of discs  
 Balancing  
 Note : hubs are not balanced.

see leaflet T08020-01

The discs 625-2 and 705-2 are with the same hub and fixing than 795.

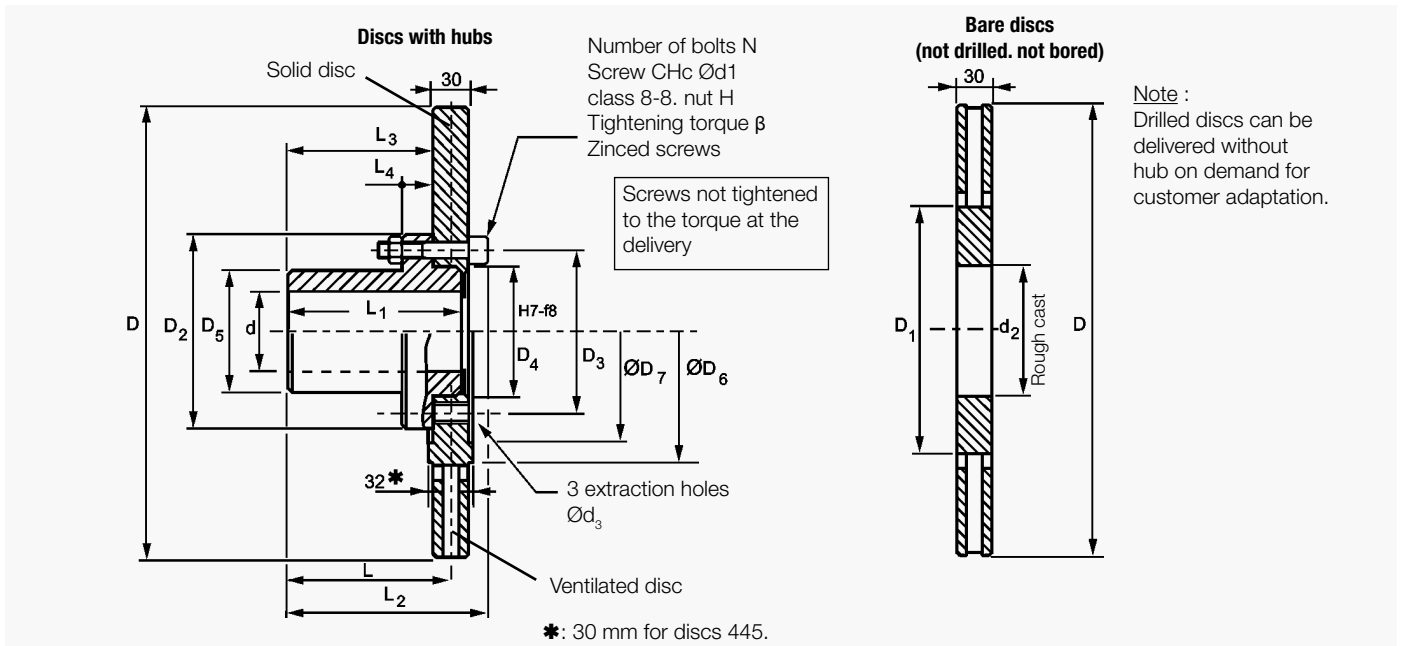

Designation	Type		625		625-2		705		705-2		795		995
			P30	V30	P30	V30	P30	V30	P30	V30	P30	V30	P30
J	Disc + hub	kg.m <sup>2</sup>	3.699	2.253	4.02	2.574	6.038	3.808	6.13	3.9	9.802	6.222	23.9
	Bare disc	kg.m <sup>2</sup>	3.506	2.06	3.45	2.004	5.69	3.46	5.62	3.39	9.23	5.65	22.5
Weight	Disc + hub	kg	96	69	116.5	89.5	117	84	136	103	191	151	271
	Bare disc	kg	68	41	63	36	86	53	82.5	49.5	110	70	170
Maximum speed	rpm		1500		1500		1300		1300		1200		900
Maximum braking torque ■	N.m		19915		36384		27905		36384		36384		73897
D	mm		625		625		705		705		795		995
D1	mm		343		343		418		418		498		-
D2	mm		235		300		265		300		300		380
D3	mm		205		260		230		260		260		330
D4	mm		170		220		195		220		220		280
D5	mm		150		210		180		210		210		260
D6	mm		-	387	-	387	-	462	-	462	-	542	-
D7	mm		-	246	-	305	-	271	-	440	-	310	-
L	mm		195		195		195		195		195		235
L1	mm		200		200		200		200		200		244
L2	mm		230		234		232		234		234		280
L3	mm		180		180		180		180		180		220
L4	mm		38		40		40		40		40		50
Bore maximum d keyed **	mm		100		140		125		140		140		180
d1	mm		M20		M24		M22		M24		M24		M30
d2	mm		161.5		161.5		185.5		185.5		211.5		211.5
d3	mm		M20		M24		M22		M24		M24		M30
N			12		12		12		12		12		12
Tightening torque β	N.m		410		710		550		710		710		1450

■ Maximum braking torque allowed by the bolts of disc and hub assembling.



**ATTENTION !**  
 The torque transmissible by shaft and keying must be checked.

\*\* Tolerance on d and keying on Customer demand.

# SIME Brakes Industrial Braking Systems

## Discs & Drums

### DRUM BRAKE - DRUMS SERIE PB & PB-C

Revision number: T01350-01-C

Revision date: 25.05.2018

**Drums material :**

∅A ≤ 400 mm : EN-GJL-250

∅A > 400 mm : EN-GJS-500-7

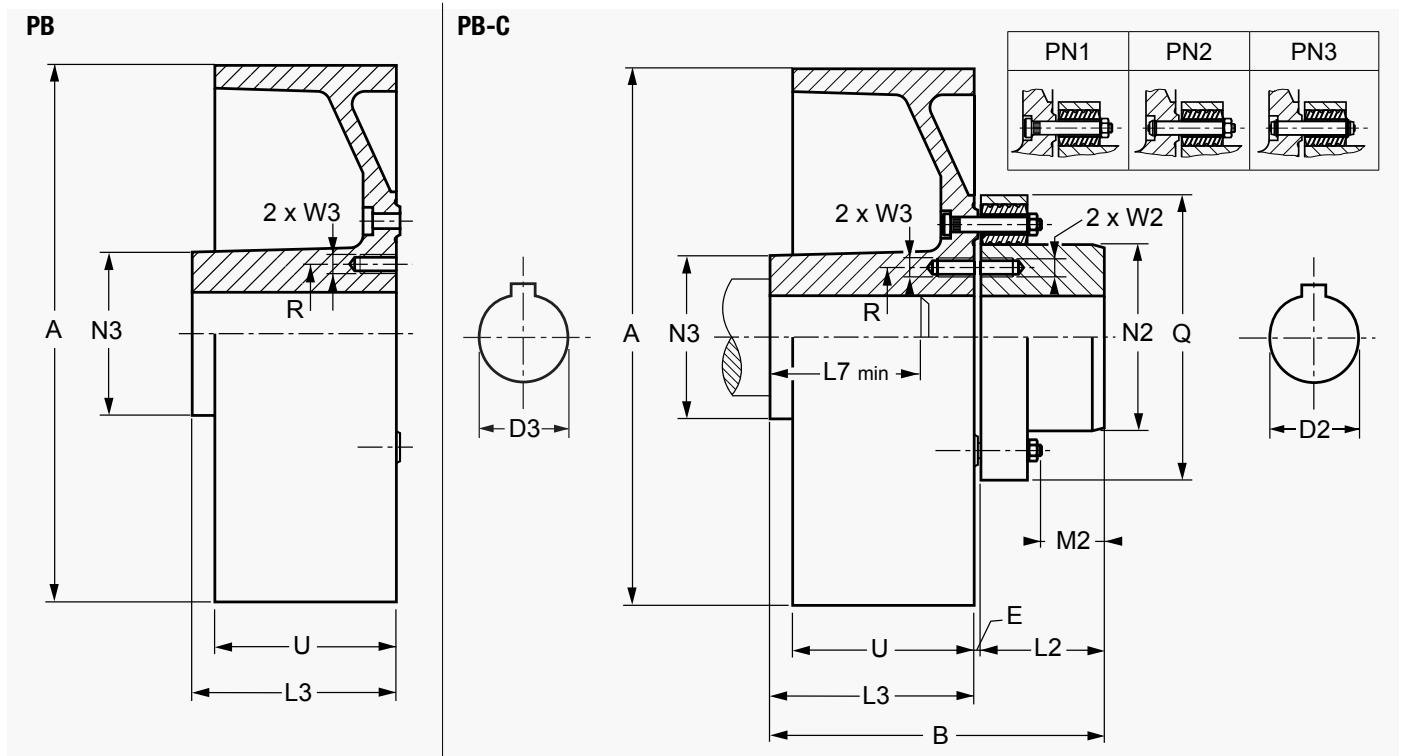

Designation		PB or PB-C...	200	250	315	400	500	630	710
J □	coupling + drum	kgm <sup>2</sup>	0.062	0.156	0.426	1.310	4.02	10.82	21.45
	drum alone	kgm <sup>2</sup>	0.052	0.137	0.393	1.229	3.718	10.518	19.958
Weight □	coupling + drum	kg	16.1	27.7	43.5	83	160	235	415
	drum alone	kg	12.5	22.6	35.9	70.1	130.5	205.5	333.4
Nominal torque		Nm	400	630	1000	2500	6100	6100	21000
Rotation speed nmax. *		rpm	3400	2750	2200	1700	2200	1800	1500
Dimensions in mm	A		200	250	315	400	500	630	710
	B		183.5	223.5	248.5	299	404	429	515.5
	E		3.5	3.5	3.5	4	4	4	5.5
	L2		60	75	90	110	150	150	220
	L3		120	145	155	185	250	275	290
	L7 min		72	87	93	110	150	165	175
	M2		21.5	36.5	51.5	51	91	91	148
	N2		95	116	127	160	202	202	290
	N3		95	116	127	160	202	202	195
	Q		<b>155</b>	<b>175</b>	<b>200</b>	<b>245</b>	<b>315</b>	<b>315</b>	<b>460</b>
	U		75	95	118	150	190	236	265
	R2		80	95	105	135	165	165	232
	R3		80	95	105	135	165	165	165
W2		M8	M10	M10	M12	M12	M12	M20	
W3		M10	M12	M12	M16	M20	M20	M20	
Bores in mm	D2 min / max ○		19/60	28/75	35/80	35/100	100/125	100/125	140/200
	D3 min / max ○		19/60	28/75	28/80	35/100	45/125	55/125	55/125
Pins	Number / size		6 /PN1	8 /PN1	10 /PN1	9 /PN2	16/PN2	16/PN2	18/PN3

Without specification on the order, couplings are delivered without boring.

\* For speeds > nmax.. consult us.

□ For maximum bore.

○ Maximum bores for keyways according to ISO R773.



## Disc Couplings

### DISC COUPLINGS

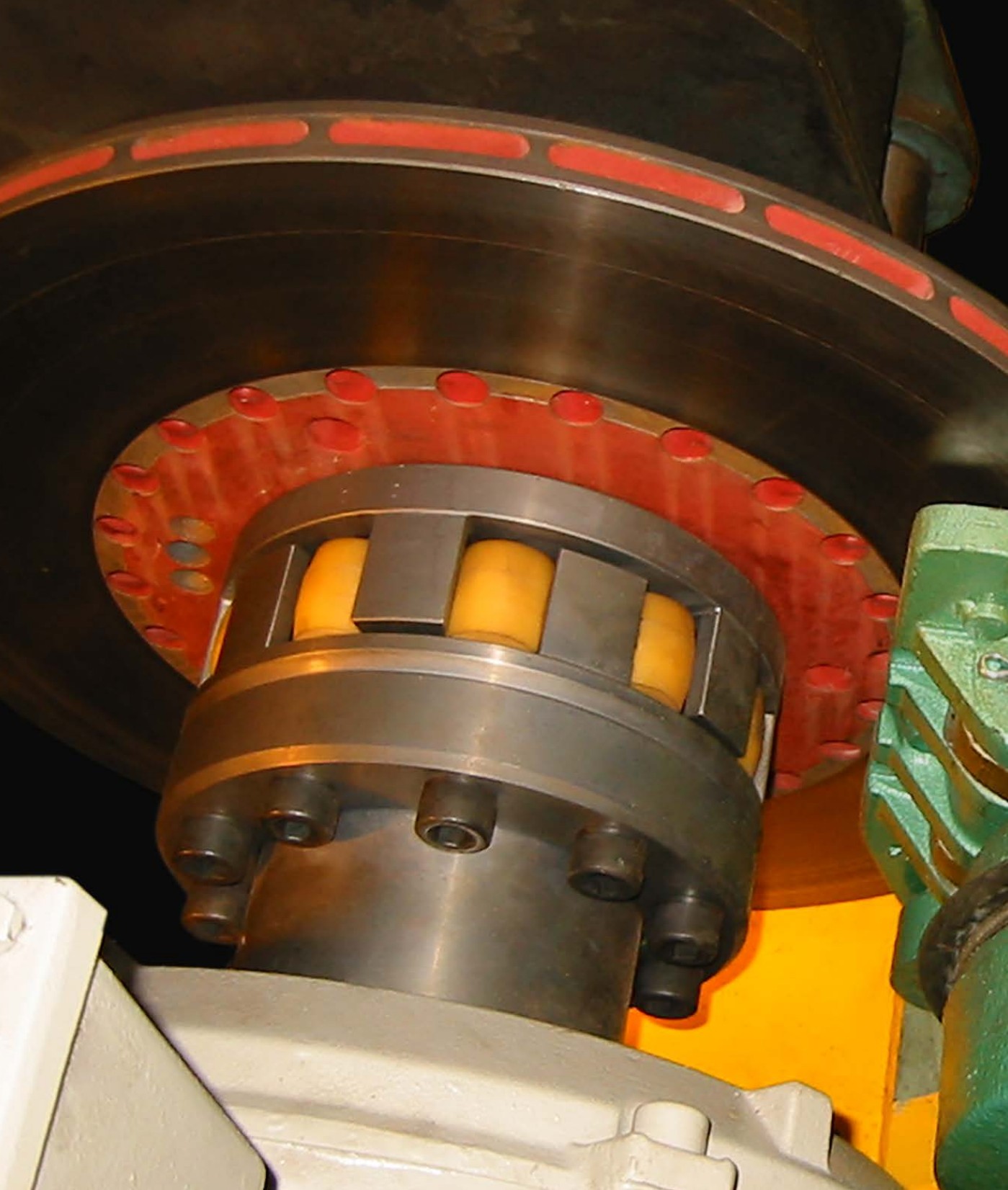

MAIN CHARACTERISTICS	OPTIONS
<ul style="list-style-type: none"> <li>• IN ASSOCIATION WITH OUR MONOBLOC, SOLID AND VENTILATED DISCS</li> <li>• 3 TYPES OF DISC COUPLINGS FOR A COMPLETE BRAKING SYSTEM SOLUTION</li> </ul>	<ul style="list-style-type: none"> <li>• LONG HUB ON MOTOR SIDE : SDKL .. SVKL .. SMLDF</li> <li>• LONG HUB ON GEAR BOX SIDE : SDF-ML</li> <li>• LONG HUBS ON MOTOR AND GEAR BOX SIDES : SDKL/SVKL-ML .. SMLDF-ML</li> </ul>



### PERIFLEX

- Highly-flexible rubber-fabric couplings
- Precise workmanship
- Monobloc. solid and ventilated discs : th.15 - 30 mm. Ø 175 - 795
- Torque range: 50 to 15.000 Nm
- Ambient temperature: -50°C to +80°C

### Benefits include

- Compensate extremely large offsets in every direction
- Allow radial mounting and dismantling without moving the machines
- Make torque transmission free from backlash
- Absorb torque peaks and damp occuring vibrations



### SDF

- All steel coupling
- Two flanged sleeves with internal spur gear teeth
- Solid and ventilated discs : th. 30 mm. Ø 315 - 995
- Torque range: 1.500 to 36.700 Nm
- High misalignments = 1°30' per gear
- Ambient temperature: -20°C to +100°C

### Benefits include

- Disc mounting and dismantling without moving the machines back
- Closely controlled quality of the gearing profile for minimum end float and best alignment



### E - SVKL - SDKL

- Highly-Flexible coupling
- Fitted with a cam ring and a flexible element (shore A or shore D).
- Discs : **E**: th.15 - 30 mm. Ø 175 - 625  
**SVKL/SDKL**: th. 30 mm. Ø 315 - 795
- Torque range:
  - **E**: 200 to 3100 Nm
  - **SVKL/SDKL**: 630 to 39700 Nm
- Ambient temperatures:
  - **E**: -40°C to +120°C
  - **SVKL/SDKL**: -25°C to +80°C

### Benefits include

- Easy assembly
- Easy dismantling of the complete coupling and cam Ring
- Damping of torsional vibrations
- Noise reduction and shock load accomodation
- No lubrication requirements

# SIME Brakes Industrial Braking Systems

## Disc Couplings

### DISC BRAKE - FLEXIBLE DISC COUPLING PNF-PNQ-PND

Revision number: T02805-01-D

Revision date: 15.05.2012

Flexible coupling **PNF**, **PNQ** and **PND** series  
 Discs thickness: 30mm  
 Rubber element and disc can be both removed  
 without moving motor or gearbox back.

**Use:**  
 PNF and PNQ for horizontal motions only.  
 PND with lugs: compulsory for hoisting.

**Option:**  
 Solid Disc

Screws 1 and 2 not tightened to the torque at the delivery

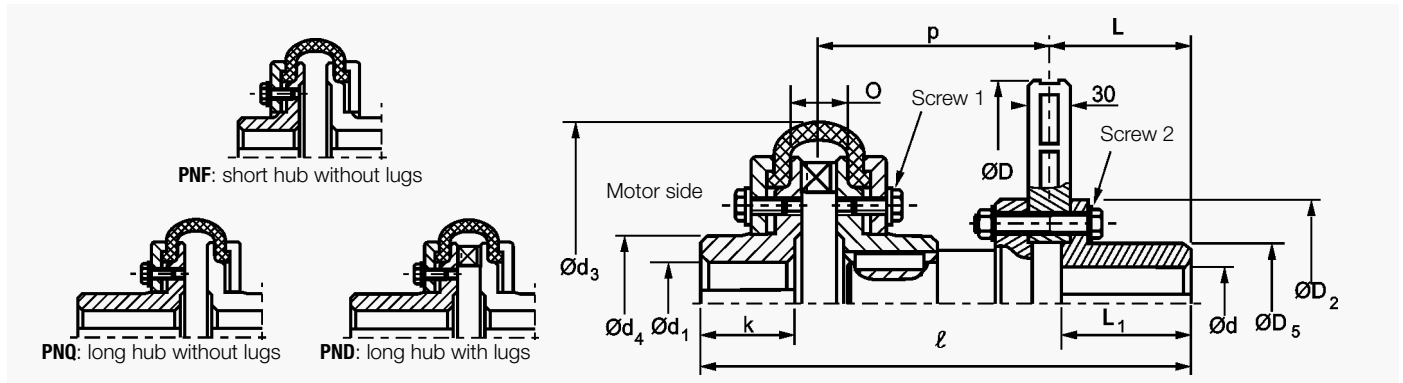

Designation	Disc	315V30		355V30		395V30		445V30				495V30							
		Coupling PNF, PNQ and PND	25	50	25	50	100	50	100	200	100-1	100-2	200-1	200-2	100-1	100-2	200-1	200-2	300-1
Nominal torque Cn	N.m	300	600	300	600	1200	600	1200	2500	1200	1200	2500	2500	1200	1200	2500	2500	4000	4000
Coupling Maximum torque Cmax	N.m	900	1800	900	1800	3600	1800	3600	7500	3600	3600	7500	7500	3600	3600	7500	7500	12000	12000
For use with calipers type		650-5K	645-5K	650	5K 650	645	645-5K		645-5K	4CA2	645-5K	4CA2	645-5K	4CA2	645-5K	4CA2	645-5K	645-5K	4CA2
Maximum speed	tr/mn	3000	2500	2700	2500	2500	2400	2400	2000	2100	2100	2000	2000	1900	1900	1900	1900	1900	1900
J:	PNF	kgm <sup>2</sup>	0.180	0.240	0.283	0.333	0.456	0.370	0.589	1.08	0.776	0.656	1.475	1.545	1.266	1.272	1.655	1.68	1.60
	PNQ	kgm <sup>2</sup>	0.182	0.252	0.286	0.344	0.483	0.382	0.616	1.116	0.803	0.683	1.516	1.586	1.293	1.299	1.696	1.721	1.64
	PND	kgm <sup>2</sup>	0.187	0.267	0.291	0.360	0.512	0.397	0.645	1.140	0.832	0.71	1.541	1.61	1.322	1.328	1.721	1.746	1.66
Weight:	PNF	kg	29.3	35.5	34.8	43	57	45.5	63	93	74	71	94	96	95	98.5	118	128	128.5
	PNQ	kg	31.3	38.5	36.8	46	67	48.5	73	103	84	81	104	106	105	108.5	128	138.5	140
	PND	kg	32.4	40.7	37.9	48.2	68.7	50.7	74.7	107.5	85.7	82.7	108.5	110.5	106.7	110	132.5	142.5	141.5
ℓ	PNF	mm	315	350	315	340	380	340	380	402	413	515	435	568	400	443	435	525	562
	PNQ, PND	mm	366	393	366	383	445	383	445	467	478	580	500	633	465	508	500	590	622
Disc	D	mm	315		355		395		445				495						
	D <sub>2</sub>	mm	125		145		165		175				220						
	D <sub>0</sub>	mm	80		95		105		110				150						
	L	mm	102		102		102		135				135						
	L <sub>1</sub>	mm	107		107		107		140				140						
	d max. keyed d max. for shrink fit	mm	50		60		70		70				100						
Coupling	d <sub>3</sub>	mm	210	263	210	263	310	263	310	370	310	310	370	370	310	310	370	370	402
	d <sub>4</sub>	mm	80	95	80	95	125	95	125	150	125	125	150	150	125	125	150	150	160
	k PNF	mm	59	67	59	67	75	67	75	85	75	75	85	85	75	75	85	85	95
	k PNQ, PND	mm	110	110	110	110	140	110	140	150	140	140	150	150	140	140	150	150	155
	O	mm	38	44	38	44	42	44	42	48	42	42	46	46	42	42	46	46	50
	p	mm	138	161	138	151	178	151	178	192.5	178	280	192.5	325.5	165	208	192.5	282.5	305
	d <sub>1</sub> max. keyed PNF	mm	55	65	55	65	90	65	90	100	90	90	100	100	90	90	100	100	110
	d <sub>1</sub> max. keyed PNQ	mm	55	65	55	65	90	65	90	100	90	90	100	100	90	90	100	100	110
	d <sub>1</sub> max. keyed PND	mm	55	65	55	65	85	65	85	100	85	85	100	100	85	85	100	100	110
	d <sub>1</sub> max. for shrink fit	mm	50	60	50	60	80	60	80	90	80	80	90	90	80	80	90	90	100
Tightening torque on screw 1	N.m	20	25	20	25	45	25	45	55	45	45	55	55	45	45	55	55	60	
Tightening torque on screw 2	N.m	49	49	86	86	86	135	135	135	210	210	210	210	290	290	290	290	290	
Maximum permissible torque Ct and working conditions (ambient temperature ≤ 40°C)		>300 start/h : Ct=Cn/2.5 ≤300 start/h à 120 start/h : Ct=Cn/2 ≤120 start/h : Ct=Cn/1.5									NOTA : For shrink fit, k and ℓ are modified (consult us) At the delivery, screws 1 and 2 are not tightened to the torque In each case : engine start coupling Cd<Cmax								



### DISC BRAKE - FLEXIBLE DISC COUPLING PNF-PNQ-PND

Revision number: T02805-01-D

Revision date: 15.05.2012

Flexible coupling **PNF, PNQ** and **PND** series  
Discs thickness: 30mm  
Rubber element and disc can be both removed without moving motor or gearbox back.

**Use:**  
PNF and PNQ for horizontal motions only.  
PND with lugs, compulsory for hoisting.

**Option:**  
Solid Disc

Screws 1 and 2 not tightened to the torque at the delivery

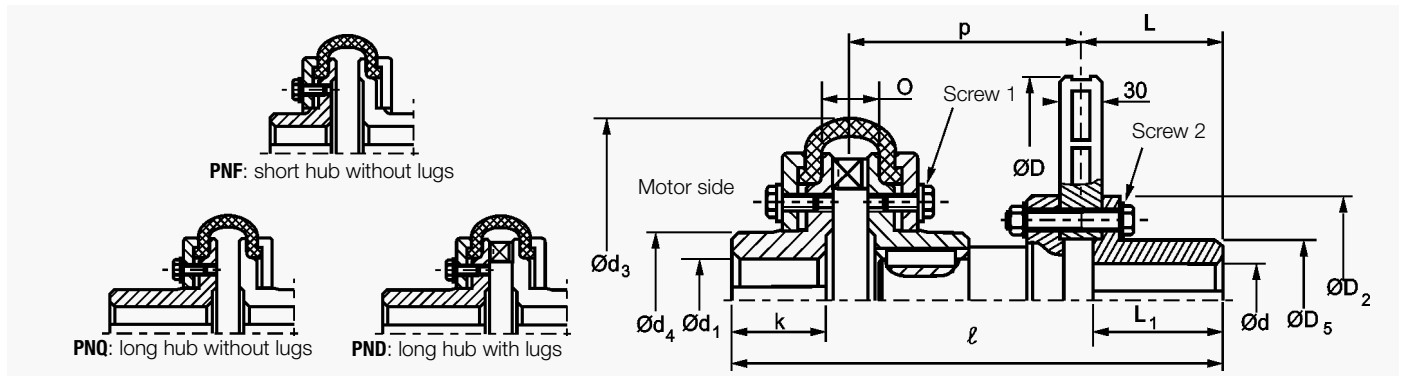

Designation		Disc	550 V 30						625 V 30			705 V 30		795 V 30			
Coupling PNF, PNQ and PND			100	200-1	200-2	300-1	300-2	300-3	200	300	400	400	800	400	800	1500	
Assembly	Coupling Nominal torque	Cn	N.m	1200	2500	2500	4000	4000	4000	2500	4000	6000	6000	10000	6000	10000	15000
	Coupling Maximum torque	Cmax	N.m	3600	7500	7500	12000	12000	12000	7500	12000	18000	18000	30000	18000	30000	45000
	For use with calipers type			645 5K	645 5K	4CA2	645 5K	4CA2	3CA2	4CA2	3CA2		3CA2		3CA2		
	Maximum speed	tr/mn		1800	1800	1800	1800	1800	1800	1500	1500	1500	1300	1250	1200	1200	900
	<b>J:</b>																
	PNF	kgm <sup>2</sup>		1.68	2.03	2.04	1.95	1.97	1.99	2.49	3.34	4.15	5.43	7.39	7.85	9.82	17.92
	PNQ	kgm <sup>2</sup>		1.70	2.07	2.08	1.98	2.00	2.03	2.53	3.38	4.25	5.52	7.54	7.95	9.96	18.17
	PND	kgm <sup>2</sup>		1.73	2.10	2.11	2.00	2.03	2.06	2.56	3.40	4.33	5.61	7.81	8.05	10.24	18.42
	Weight:																
	PNF	kg		101	124	126	123	131.5	134.5	137	151	182	191	258	207	283	587
PNQ	kg		111	134.5	136.5	134	142.5	145.5	147.5	162.5	202	211	281	227	305.5	623.5	
PND	kg		112.7	138.5	140.5	136	144.5	148.5	151.5	164	206	215	297.5	231	322.5	641.5	
<b>ℓ</b>																	
PNF	mm		400	435	450	470	535	580	450	470	575	495	635	495	635	810	
PNQ, PND	mm		465	500	515	530	595	640	515	530	655	575	715	575	715	905	
Disc	D	mm	550						625			705		795			
	D <sub>2</sub>	mm	220						235			265		300			
	D <sub>5</sub>	mm	150						150			180		210			
	L	mm	135						135			135		135			
	L <sub>1</sub>	mm	140						140			140		140			
	d max. keyed	mm	100						100			120		130			
d max. for shrink fit	mm	100						100			120		130				
Coupling	d <sub>3</sub>	mm	310	370	370	402	402	402	370	402	450	450	550	450	550	700	
	d <sub>4</sub>	mm	125	150	150	160	160	160	150	160	180	180	210	180	210	270	
	k PNF	mm	75	85	85	95	95	95	85	95	110	110	130	110	130	160	
	k PNQ, PND	mm	140	150	150	155	155	155	150	155	190	190	210	190	210	255	
	O	mm	42	46	46	50	50	50	46	50	70	70	120	70	120	150	
	p	mm	165	192.5	207.5	213	278	323	207.5	213	300	220	320	220	320	400	
	d <sub>1</sub> max. keyed PNF	mm	90	100	100	110	110	110	100	110	110	110	130	110	130	18	
	d <sub>1</sub> max. keyed PNQ	mm	90	100	100	110	110	110	100	110	120	120	120	120	140	180	
	d <sub>1</sub> max. keyed PND	mm	90	100	100	110	110	110	100	110	120	120	120	120	140	180	
	d <sub>1</sub> max. for shrink fit	mm	80	90	90	100	100	100	80	100	105	105	120	105	120	170	
Tightening torque for screw 1	N.m	45	55	55	60	60	60	55	60	110	110	200	110	200	240		
Tightening torque for screw 2	N.m	290	290	290	290	290	290	410	410	410	550	550	710	710	710		
Maximum permissible torque Ct and working conditions (ambient temperature ≤ 40°C)			>300 start/h : Ct=Cn/2.5 ≤300 start/h à 120 start/h : Ct=Cn/2 ≤120 start/h : Ct=Cn/1.5						<b>NOTA :</b> For shrink fit, k and ℓ are modified (consult us) At the delivery, screws 1 and 2 are not tightened to the torque In each case : engine start coupling Cd<Cmax								

# SIME Brakes Industrial Braking Systems

## Disc Couplings

### DISC BRAKE - FLEXIBLE DISC COUPLING PNK

Revision number: T02561-01-B

Revision date: 25.11.2010

Flexible coupling **PNK** series  
 Solid disc thickness 15 mm  
 Rubber element and disc can both be removed  
 without disturbing motor or gearbox  
 Without lug.

**Use:**  
 For horizontal motions  
 For hoist motions, please consult us.

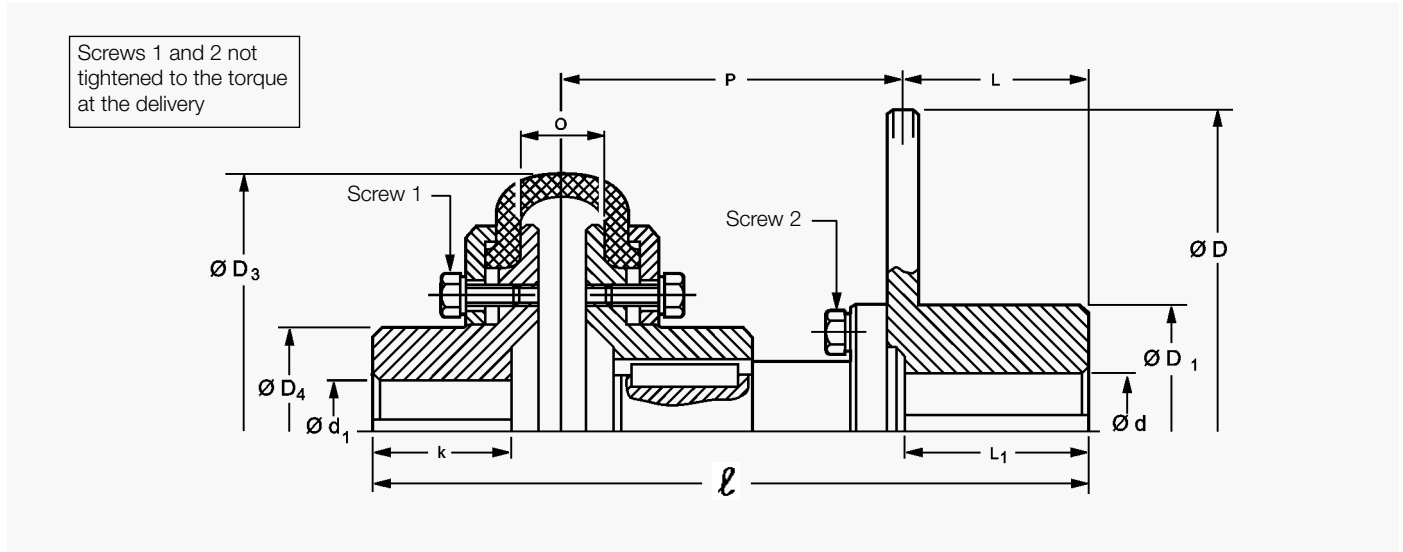

Designation		Disc		175P15			220P15			260P15		315P15		395P15		445P15		495P15	550P15	625P15	
Flexible coupling PNK		2	6	16	2	6	16	6	16	16	40	40	63	40	63	63	125	125	160	160	2000
Assembly	Coupling	Cn	Nm	50	100	200	50	100	200	100	200	200	400	400	800	400	800	800	1600	1600	2000
	Nominal torque	Cmax	Nm	150	300	600	150	300	600	300	600	600	1200	1200	2400	1200	2400	2400	4800	4800	6000
	combined caliper			660	650	660	650	660	650	650	645	650	645	650	645	645	645	645	645	645	645
	Maximum speed	tr/mn		5000	5000	4000	4300	4300	4000	3600	3600	3000	3000	2400	2400	2100	2100	1900	1800	1500	1500
	J	kgm <sup>2</sup> Fl. coupling and disc		0.011	0.013	0.023	0.030	0.042	0.045	0.066	0.076	0.146	0.168	0.338	0.408	0.520	0.595	0.89	1.42	2.19	2.58
	Weight	kg		6	7.4	11	9.4	11.6	15.3	18	21.4	26	31.5	38.5	46	42	51	69	89	100	120
Disc	D	mm		175		220		260		315		395		445		495		550		625	
	D <sub>1</sub>	mm		75		95		120		120		120		120		150		150		150	
	L	mm		55		65		85		102		102		102		135		135		135	
	L	mm		58.5		68.5		88.5		112		112		112		145		145		145	
	Bore d	mm		40		55		75		75		75		75		100		100		100	
	max. shrink fit *	mm		35		50		65		65		65		65		90		90		90	
Flexible coupling	D <sub>3</sub>	mm	104	136	178	104	136	178	136	178	178	210	210	263	210	263	263	310	310	370	
	D <sub>4</sub>	mm	40	55	70	40	55	70	55	70	70	92	92	107	92	107	107	140	140	150	
	k	mm	30	45	50	30	45	50	45	50	50	65	65	75	65	75	75	100	100	85	
	O	mm	16	18	35	16	18	35	18	35	35	38	38	44	38	44	44	42	42	46	
	P	mm	95	105	130	95	105	120	105	115	128	158	158	173	158	173	180	205	205	192.5	
	Bore max. d <sub>1</sub> keyed shrink fit *	mm	28	38	48	28	38	48	38	48	48	65	65	75	65	75	75	100	100	100	
Tightening torque in Nm	Screw 1	mm	4	6	15	4	6	15	6	15	15	20	20	25	25	25	45	45	55		
	Screw 2	mm	25	25	25	25	25	25	25	25	49	69	86	120	86	120	210	210	295		
Max. transmissible torque (Ct) and working conditions (ambient temperature ≤ 40°C)		> 300 starts/ hour: Ct = Cn / 2.5 ≤ 300 starts/ hour to 120 starts/ hour: Ct = Cn / 2 ≤ 120 starts/ hour: Ct = Cn / 1.5										* For shrink fit, dimensions k and l are altered (consult us) In each case, motor starting torque Cd < Cmax									

### DISC BRAKE - FLEXIBLE DISC COUPLING PNM

Revision number: T02661-01-B

Revision date: 25.11.2010

Coupling **PNM** series  
 Monobloc disc with thickness: 30mm  
 Rubber element and disc can both be removed  
 without moving motor or gearbox back  
 Without lug

**Use:**  
 For horizontal motions.  
 For hoist motions, consult us.

Screws 1 and 2 not  
 tightened to the torque  
 at the delivery

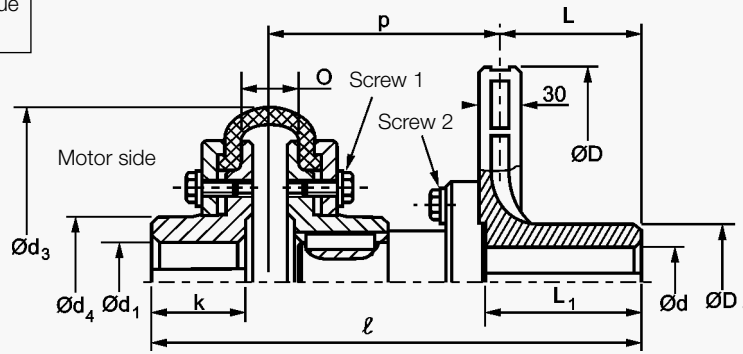

Designation		Disc Coupling PNM	220M30			260M30			315M30			
			2	6	16	6	16	40	16	40	63	
Assembly	Nominal coupling torque Cn	Nm	50	100	200	100	200	400	200	400	800	
	Maximum coupling torque Cmax	Nm	150	300	600	300	600	1200	600	1200	2400	
	For use with calipers		650 - 5D			650 - 5D			650 - 5D - 5K			
	Maximum speed	tr/mn	4300	4300	4000	3600	3600	3600	3000	3000	3000	
	<b>J</b>	kgm <sup>2</sup>	0.056	0.06	0.07	0.072	0.085	0.107	0.155	0.178	0.248	
	Weight	kg	13	15.2	19	15	18.4	22.5	20	25.5	33.5	
	<b>ℓ</b>	mm	244.5	277	309.5	275.5	295.5	332	295	340	358	
Disc	D	mm	220			260			315			
	D <sub>1</sub>	mm	85			85			90			
	L	mm	102			102			102			
	L <sub>1</sub>	mm	112			112			112			
	d min.	mm	20			30			35			
	d max. keyed	mm	55			55			60			
Coupling	d <sub>3</sub>	mm	104	136	178	136	178	210	178	210	263	
	d <sub>4</sub>	mm	40	55	70	55	70	92	70	92	107	
	k	mm	30	45	50	45	50	65	45	65	75	
	O	mm	16	18	35	18	35	38	35	38	44	
	p	mm	107.5	120	142.5	118.5	128.5	150	128	158	161	
	d <sub>1</sub> max. keyed	mm	28	38	48	38	48	65	48	65	75	
	Tightening torque of screws 1	Nm	4	6	15	6	15	20	20	20	20	
	Tightening torque of screws 2	Nm	25	25	25	25	25	69	49	69	69	
	Maximum permissible torque Ct and working conditions (ambient temperature ≤ 40°C)			>300 start/h : Ct=Cn/2.5 ≤300 start/h at 120 start/h : Ct=Cn/2 ≤120 start/h : Ct=Cn/1.5					In each case, motor starting torque Cd < Cmax Other versions, consult us.			

# SIME Brakes Industrial Braking Systems

## Disc Couplings

### DISC BRAKE - GEAR DISC COUPLING SDF

Revision number: T10004-01-C

Revision date: 03.02.2010

Gear coupling type **SDF**

Solid discs (**P**) and ventilated discs (**V**)  
thickness 30mm

Disc mounting and dismounting without  
moving the machines back.

Stromag provides also the couplings:

**SDF-ML** with long hub on gear box side

**SMLDF** with long hub on motor side

**SMLDF-ML** with long hub on each side,  
consult us.

Hub and coupling : oiling protection.

Material and balancing of the discs : see  
the discs "technical data" leaflet

In standard, only the disc is balanced.  
The assembly is balanced on demand.  
(parts angularly matched).

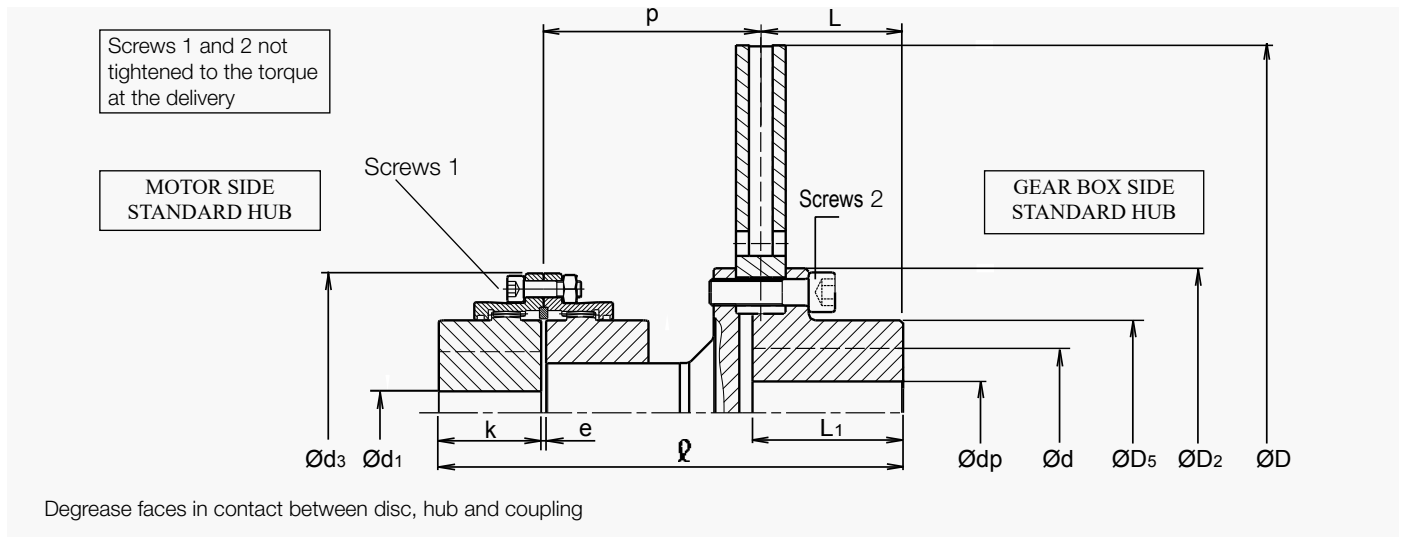

Designation		Disc	315 P30/V30		355 P30/V30		395 P30/V30				
		SDF	68		68		68		80		
Assembly	<b>J</b>	<b>P30</b> <b>V30</b>	kg.m <sup>2</sup>	0.246	0.16	0.391	0.255	0.604	0.368	0.622	0.386
	Weight	<b>P30</b> <b>V30</b>	kg	32	25	39	30	47.5	36.5	53	42
	$\varnothing$		mm	274		274		274		286	
	Maximum speed		rpm	3000		2700		2400			
	Maximum braking torque		N.m	Tb ≤ Tp (Tb = maximum braking torque. Tp = maximum peak torque)							
For use with calipers			Check that D - D2 > width of the caliper braking surface (ex.: 4CA2 and 3CA2 not associated to discs D < 445) Check that the caliper nominal braking torque is ≤ Tp								
Disc	D	mm	315		355		395				
	D2	mm	124		145		165				
	D5	mm	82		100		112				
	L	mm	102		102		102				
	L1	mm	107		107		107				
	dp	mm	--		--		--				
	d maximum keyed	mm	55		70		75				
	d max. shrink fit	mm	50		60		70				
Tightening torque screw 2 *	N.m	49		86		135					
Coupling	d3	mm	140		140		140		169		
	e	mm	3		3		3		3		
	k	mm	50		50		50		62		
	p	mm	120.5		120.5		120.5		120.5		
	d1 maximum keyed	mm	68		68		68		80		
	d1 max. shrink fit	mm	63		63		63		75		
	Tightening torque screws 1 *	N.m	33		33		33		60		
	Maximum peak torque (Tp)	N.m	1500		2200		2200				
Transmissible torque (Tt)	N.m	750		1100		1100					
In every case : Ts < Tp (Ts : motor starting torque)											

\*: greased under head and on thread

### DISC BRAKE - GEAR DISC COUPLING SDF

Revision number: T10004-01-C

Revision date: 03.02.2010

Gear coupling type **SDF**

Solid discs (**P**) and ventilated discs (**V**)  
thickness 30mm

Disc mounting and dismounting without  
moving the machines back.

Stromag provides also the couplings:

**SDF-ML** with long hub on gear box side

**SMLDF** with long hub on motor side

**SMLDF-ML** with long hub on each side,  
consult us.

Hub and coupling : oiling protection.

Material and balancing of the discs : see  
the discs "technical data" leaflet

In standard, only the disc is balanced.  
The assembly is balanced on demand.  
(parts angularly matched).

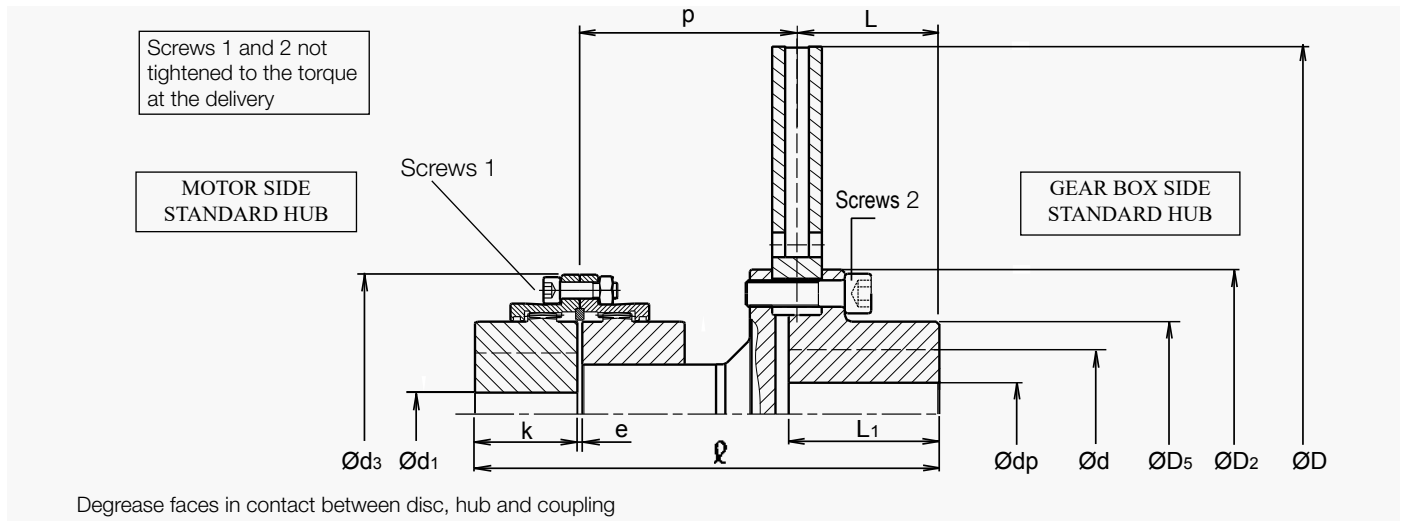

Designation				Disc	705 P30/V30								795 P30/V30							
					SDF		115		135		150		170		135		150		170	
Assembly	J	P30	V30	kg.m <sup>2</sup>	6.165	3.935	6.37	4.14	6.655	4.425	7.153	4.923	10.092	6.512	10.378	6.798	10.872	7.292		
	Weight	P30	V30	kg	173	140	196	163	223	190	259	226	233	193	260	220	295	255		
	Ø			mm	410		441		483		513		441		483		513			
	Maximum speed			rpm	1300								1200							
	Maximum braking torque			N.m	Tb ≤ Tp (Tb = maximum braking torque. Tp = maximum peak torque)															
For use with calipers					Check that D – D2 > width of the caliper braking surface (ex.: 4CA2 and 3CA2 not associated to discs D < 445) Check that the caliper nominal braking torque is ≤ Tp															
Disc	D			mm	705								795							
	D2			mm	268								300							
	D5			mm	190								216							
	L			mm	135								135							
	L1			mm	140								140							
	dp			mm	30								30							
	d maximum keyed			mm	135								150							
	d max. shrink fit			mm	120								135							
Tightening torque screw 2 *			N.m	550								710								
Coupling	d3			mm	228	266	298	330	266	298	330	266	298	330						
	e			mm	5	6	6	8	6	6	8	6	6	8						
	k			mm	90	105	120	135	105	120	135	105	120	135						
	p			mm	182.5	198	225	239	198	225	239	198	225	239						
	d1 maximum keyed			mm	115	135	150	170	135	150	170	135	150	170						
	d1 max. shrink fit			mm	106	125	140	160	125	140	160	125	140	160						
	Tightening torque screws 1 *			N.m	95	171	235	235	171	235	235	171	235	235						
	Maximum peak torque (Tp)			N.m	9400	13800	25300	29200	13800	25300	36700									
	Transmissible torque (Tt)			N.m	4700	6900	12650	14600	6900	12650	18350									
	In every case : Ts < Tp (Ts : motor starting torque)																			

\*: greased under head and on thread

# SIME Brakes Industrial Braking Systems

## Disc Couplings

### DISC BRAKE - GEAR DISC COUPLING SDF

Revision number: T10004-01-C

Revision date: 03.02.2010

Gear coupling type **SDF**

Solid discs (**P**) and ventilated discs (**V**)  
thickness 30mm

Disc mounting and dismounting without  
moving the machines back.

Stromag provides also the couplings:

**SDF-ML** with long hub on gear box side

**SMLDF** with long hub on motor side

**SMLDF-ML** with long hub on each side,  
consult us.

Hub and coupling : oiling protection.

Material and balancing of the discs : see  
the discs "technical data" leaflet

In standard, only the disc is balanced.  
The assembly is balanced on demand.  
(parts angularly matched).

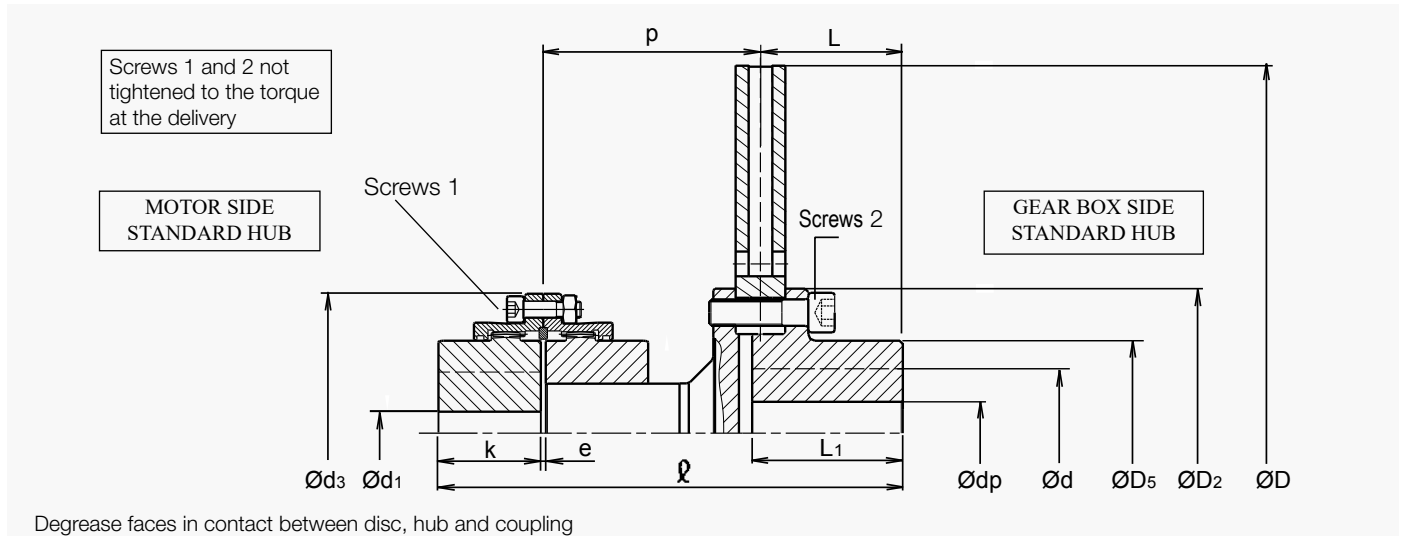

Designation				Disc	550 P30/V30						625 P30/V30								
				SDF	80		100		115		100		115		135		150		
Assembly	<b>J</b>	<b>P30</b>	<b>V30</b>	kg.m <sup>2</sup>	2.247	1.307	2.297	1.357	2.387	1.447	3.775	2.329	3.863	2.417	4.065	2.619	4.352	2.906	
	Weight	<b>P30</b>	<b>V30</b>	kg	97	74	108	85	123	100	131	104	145	118	167	140	195	168	
	$\varnothing$				mm	347		380		410		380		410		441		483	
	Maximum speed				rpm	1800						1500							
	Maximum braking torque				N.m	Tb ≤ Tp (Tb = maximum braking torque. Tp = maximum peak torque)													
For use with calipers				Check that D – D2 > width of the caliper braking surface (ex.: 4CA2 and 3CA2 not associated to discs D < 445) Check that the caliper nominal braking torque is ≤ Tp															
Disc	D				mm	550						625							
	D2				mm	218						238							
	D5				mm	155						168							
	L				mm	135						135							
	L1				mm	140						140							
	dp				mm	30						30							
	d maximum keyed				mm	110						120							
	d max. shrink fit				mm	100						105							
Tightening torque screw 2 *				N.m	290														
Coupling	d3				mm	169	200	228	200	228	200	228	266	298					
	e				mm	3	5	5	5	5	5	5	6	6					
	k				mm	62	76	90	76	90	76	90	105	120					
	p				mm	148.5	166.5	182.5	166.5	182.5	166.5	182.5	198	225					
	d1 maximum keyed				mm	80	100	115	100	115	100	115	135	150					
	d1 max. shrink fit				mm	75	92	106	92	106	92	106	125	140					
	Tightening torque screws 1 *				N.m	60	60	95	60	95	60	95	171	235					
	Maximum peak torque (Tp)				N.m	3800	6000	9400	6000	9400	6000	9400	13800	20700					
	Transmissible torque (Tt)				N.m	1900	3000	4700	3000	4700	3000	4700	6900	10350					
	In every case : Ts < Tp (Ts : motor starting torque)																		

\*: greased under head and on thread

### DISC BRAKE - GEAR DISC COUPLING SDF

Revision number: T10004-01-C

Revision date: 03.02.2010

Gear coupling type **SDF**

Solid discs (**P**) and ventilated discs (**V**)  
thickness 30mm

Disc mounting and dismounting without  
moving the machines back.

Stromag provides also the couplings:

**SDF-ML** with long hub on gear box side

**SMLDF** with long hub on motor side

**SMLDF-ML** with long hub on each side,  
consult us.

Hub and coupling : oiling protection.

Material and balancing of the discs : see  
the discs "technical data" leaflet

In standard, only the disc is balanced.  
The assembly is balanced on demand.  
(parts angularly matched).

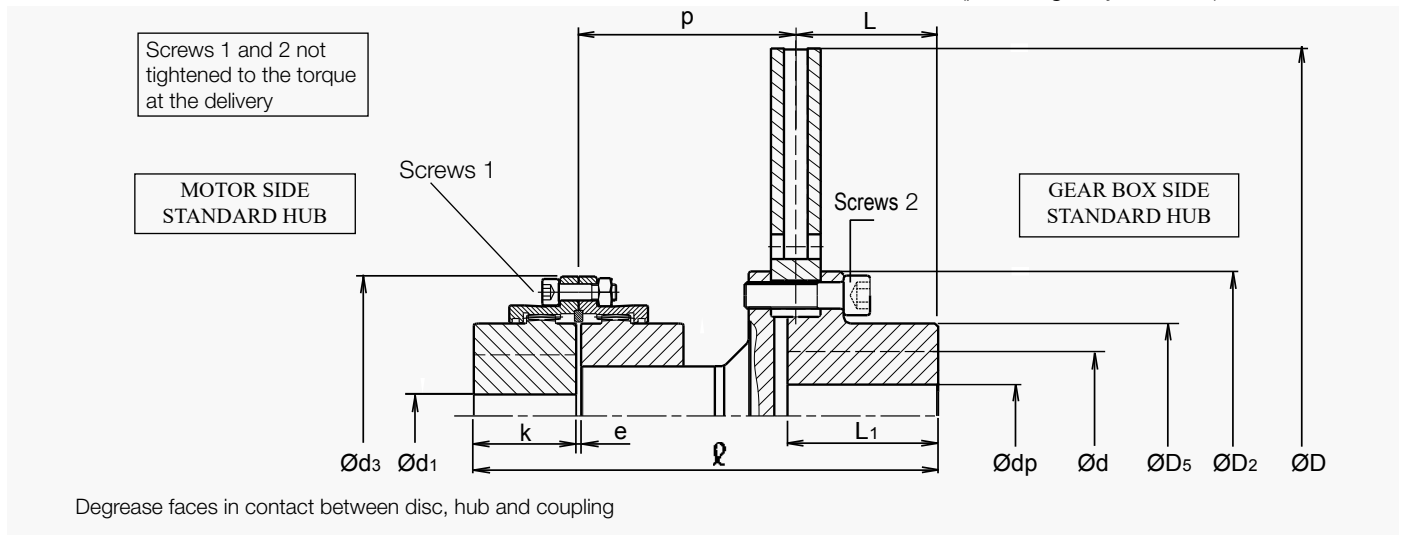

Designation				Disc SDF	705 P30/V30								795 P30/V30					
					115		135		150		170		135		150		170	
Assembly	<b>J</b>	<b>P30</b>	<b>V30</b>	kg.m <sup>2</sup>	6.165	3.935	6.37	4.14	6.655	4.425	7.153	4.923	10.092	6.512	10.378	6.798	10.872	7.292
	Weight	<b>P30</b>	<b>V30</b>	kg	173	140	196	163	223	190	259	226	233	193	260	220	295	255
	Ø			mm	410		441		483		513		441		483		513	
	Maximum speed			rpm	1300								1200					
	Maximum braking torque			N.m	Tb ≤ Tp (Tb = maximum braking torque. Tp = maximum peak torque)													
For use with calipers					Check that D - D2 > width of the caliper braking surface (ex.: 4CA2 and 3CA2 not associated to discs D < 445) Check that the caliper nominal braking torque is ≤ Tp													
Disc	D			mm	705								795					
	D2			mm	268								300					
	D5			mm	190								216					
	L			mm	135								135					
	L1			mm	140								140					
	dp			mm	30								30					
	d maximum keyed			mm	135								150					
	d max. shrink fit			mm	120								135					
Tightening torque screw 2 *				N.m	550								710					
Coupling	d3			mm	228	266	298	330	266	298	330	266	298	330	266	298	330	
	e			mm	5	6	6	8	6	6	8	6	6	8	6	6	8	
	k			mm	90	105	120	135	105	120	135	105	120	135	105	120	135	
	p			mm	182.5	198	225	239	198	225	239	198	225	239	198	225	239	
	d1 maximum keyed			mm	115	135	150	170	135	150	170	135	150	170	135	150	170	
	d1 max. shrink fit			mm	106	125	140	160	125	140	160	125	140	160	125	140	160	
	Tightening torque screws 1 *				N.m	95	171	235	235	171	235	235	171	235	235	171	235	235
	Maximum peak torque (Tp)				N.m	9400	13800	25300	29200	13800	25300	36700	13800	25300	36700	13800	25300	36700
	Transmissible torque (Tt)				N.m	4700	6900	12650	14600	6900	12650	18350	6900	12650	18350	6900	12650	18350
	In every case : Ts < Tp (Ts : motor starting torque)																	

\*: greased under head and on thread

# SIME Brakes Industrial Braking Systems

## Disc Couplings

### DISC BRAKE - FLEXIBLE DISC COUPLING E

Revision number: T02580-01-B

Revision date: 25.11.2010

Flexible coupling "NORMEX" E series

Solid discs Ø 175 to 395

Disc thickness: 15 mm

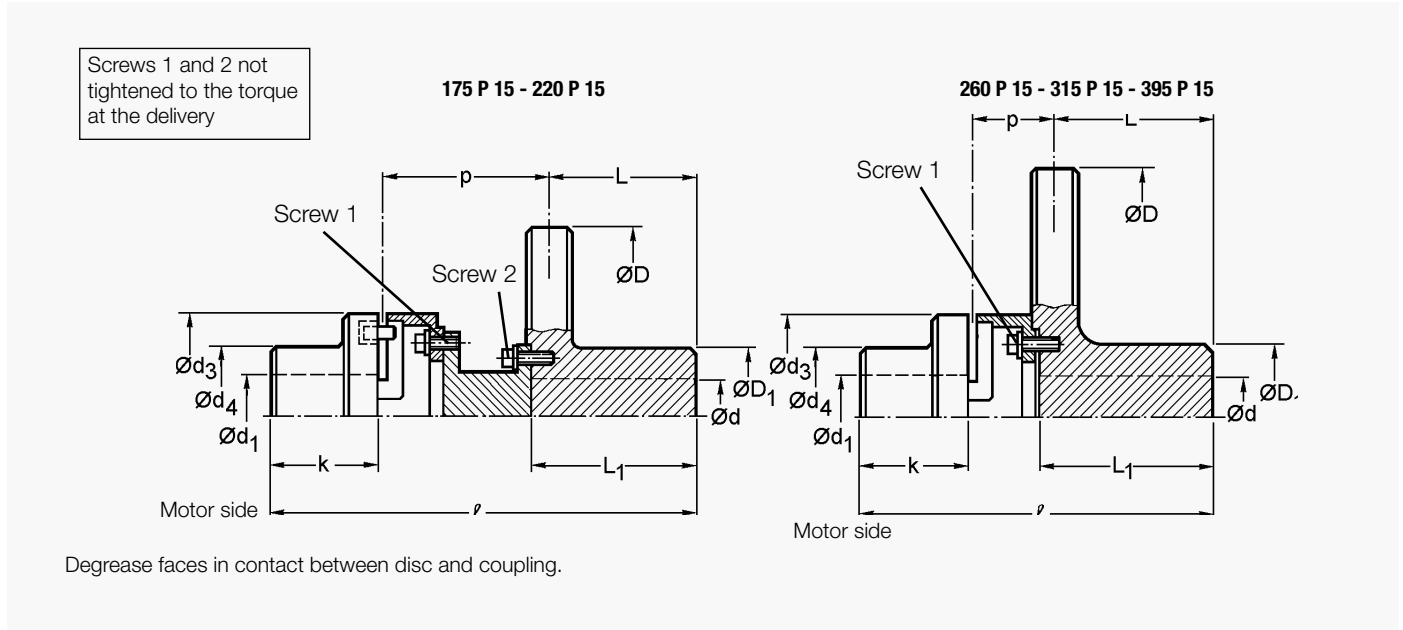

Designation	Disc type Coupling	175 P 15		220 P 15		260 P 15		315 P 15			395 P 15				
		97	112	112	128	112	128	112	128	148	128	148	168		
Assembly	J	kgm <sup>2</sup>		0.017	0.019	0.038	0.042	0.065	0.070	0.13	0.135	0.14	0.31	0.315	0.335
	Weight	kg		8	9.5	12.5	15.5	18	21	22	24	28	30	34	39
	For use with caliper	Type		660-650		660-650		660-650		660-650			660-650		
	Maximum speed	t/mn		5000		4 300		3 600		3 000			2 400		
Disc	ℓ	mm		183	244	211	244	190	201	214.5	225.5	230	225.5	230	245
	D	mm		175	175	220	220	260	260	315	315	315	395	395	395
	D <sub>1</sub>	mm		75	75	95	95	120	120	120	120	120	120	120	120
	L	mm		55	55	65	65	85	85	102	102	102	102	102	102
	L <sub>1</sub>	mm		58.5	58.5	68.5	68.5	88.5	88.5	113	113	112	112	112	112
	d max. keyed	mm		44		55		55		60			65		
	d max. for shrink fit	mm		40		55		55		60			65		
	Coupling	d <sub>3</sub>	mm		97	112	112	128	112	128	112	128	148	128	148
d <sub>4</sub>		mm		69	79	79	90	79	90	79	90	107	90	107	124
k		mm		50	60	60	70	60	70	60	70	80	70	80	90
p		mm		76.5	127.25	84.25	107.25	43.25	44.25	50.75	51.75	46.25	51.75	46.25	51.25
d, max. keyed		mm		42	48	48	55	48	55	48	55	65	55	65	75
Peak max. torque (Cp)		Nm		200	310	310	500	310	500	310	500	800	500	800	1300
Max. permissible torque (Ct) and working conditions (Ambient temperature ≤ 40 °C)				150 starts/ hour 300 starts/ hour 600 starts/ hour		8 h/24 h - Ct ≤ Cp/2.5 8 h/24 h - Ct ≤ Cp/3.2 8 h/24 h - Ct ≤ Cp/4		In every case: Cd < Cp (Cd motor starting torque) (Ct: motor nominal torque)							
Tightening torque on screws (1) and (2) *		Nm		10	25	25	25	25	25	25	25	49	25	49	86

\*: stopped with normal glue



### DISC BRAKE - FLEXIBLE DISC COUPLING E

Revision number: T02580-01-B

Revision date: 25.11.2010

Flexible coupling "NORMEX" E series

Solid discs Ø 445 to 625

Disc thickness: 15 mm

Screws 1 not tightened to the torque at the delivery

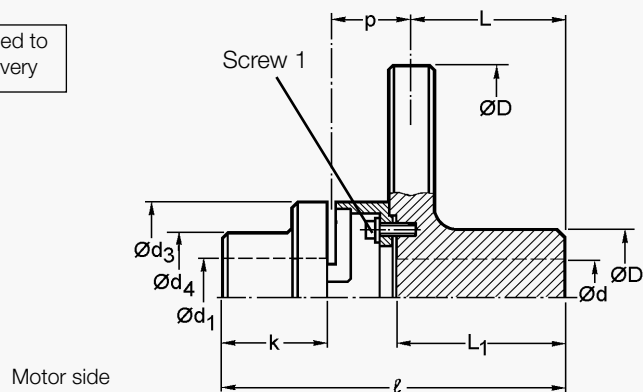

Degrease faces in contact between disc and coupling.

Designation		Disc type	445 P 15				495 P 15			550 P 15				625 P 15			
			Coupling		128	148	168	194	148	168	194	148	168	194	214	168	194
Assembly	J	kgm <sup>2</sup>	0.49	0.495	0.515	0.55	0.785	0.815	0.84	1.175	1.205	1.23	1.30	1.975	2	2.07	
	Weight	kg	33	37	43	51	52	58	66	58	64	72	80	74	82	90	
	For use with caliper	Type	660-650-645				660-650-645			660-650-645				660-650-645			
	ℓ	mm	225.5	230	245	260	263	278	293	263	278	293	308	278	293	308	
Disc	D	mm	445	445	445	445	495	495	495	550	550	550	550	625	625	625	
	D <sub>1</sub>	mm	120	120	120	120	150	150	150	150	150	150	150	150	150	150	
	L <sub>1</sub>	mm	102	102	102	102	135	135	135	135	135	135	135	135	135	135	
	L <sub>1</sub>	mm	112	112	112	112	145	145	145	145	145	145	145	145	145	145	
	d max. keyed	mm	60	65		65	65	70	70	65	70	70	90	70	70	90	
d max. for shrink fit	mm	60	65		65	65	70	70	65	70	70	90	70	70	90		
Coupling	d <sub>3</sub>	mm	128	148	168	194	148	168	194	148	168	194	214	168	194	214	
	d <sub>4</sub>	mm	90	107	124	140	107	124	140	107	124	140	157	124	140	157	
	k	mm	70	80	90	100	80	90	100	80	90	100	110	90	100	110	
	p	mm	51.75	46.25	51.25	56.25	46.25	51.25	56.25	46.25	51.25	56.25	61	51.25	56.25	61	
	d <sub>1</sub> max. keyed	mm	55	65	75	85	65	75	85	65	75	85	95	75	85	95	
	Peak max. torque (Cp)	Nm	500	800	1300	2000	800	800	2000	2000	1300	2000	3100	1300	2000	3100	
	Max. permissible torque (Ct) and working conditions (Ambient temperature ≤ 40 °C)		150 starts / hour 8 h/24 h - Ct ≤ Cp/2.5 300 starts / hour 8 h/24 h - Ct ≤ Cp/3.2 600 starts / hour 8 h/24 h - Ct ≤ Cp/4									In every case: Cd < Cp (Cd motor starting torque) (Ct: motor nominal torque)					
	Tightening torque on screw (1) *	Nm	25	49	86	86	49	86	86	49	86	86	135	86	86	135	

\*: stopped with normal glue

# SIME Brakes Industrial Braking Systems

## Disc Couplings

### DISC BRAKE - FLEXIBLE DISC COUPLING E

Revision number: T02680-01-B

Revision date: 25.11.2010

Flexible coupling E series

Monobloc discs Ø 220 - 260 - 315

Disc thickness: 30 mm

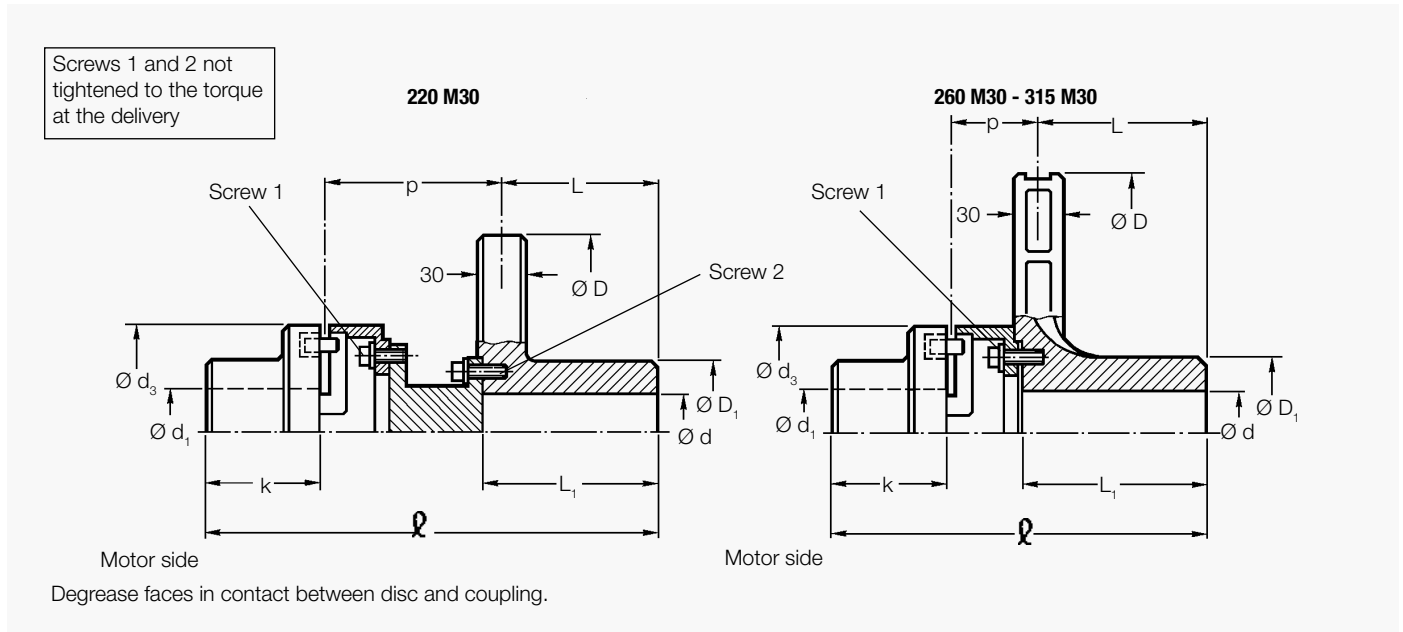

Designation		Disc Flexible coupling	220 M 30		260 M 30		315 M 30			
			112	128	112	128	112	128	148	
Assembly	J	kgm <sup>2</sup>	0.063	0.067	0.078	0.09	0.145	0.155	0.160	
	Weight	kg	16.2	19.2	15	18	17	20	24.5	
	For use with calipers	Type	650-5D		650-5D		650-5D-5K		650-5D	
	Maximum speed	r.p.m.	4 300		3 600		3 000			
Disc	$\varnothing$	mm	313.5	323.5	220.5	231.5	231.5	225.5	230	
	D	mm	220		260		315			
	D <sub>1</sub>	mm	85		85		90			
	L	mm	102		102		102			
	L <sub>1</sub>	mm	113		120		113			
	d (pilot bore)	mm	20		30		35			
	d maxi keyed	mm	55		55		60			
	d maxi shrink fitted	mm	55		55		60			
	Coupling Pb75	k	mm	60	70	60	70	60	70	80
		p	mm	149.75	149.75	56.75	57.75	50.75	51.75	46.25
d <sub>3</sub>		mm	112	128	112	128	112	128	148	
d <sub>1</sub> maxi keyed		mm	48	55	48	55	48	55	65	
d <sub>1</sub> maxi shrink fitted		mm	-	-	-	-	-	-	-	
Peak maxi. torque (Cp)		N.m	310	500	310	500	310	500	800	
Transmissible torque (Ct) and working conditions (ambient temperature ≤ 40°C) (Ct: motor nominal torque)			150 starts/hour 300 starts/hour 600 starts/hour (in every case: Cd < Cp)		8 h/24 h - Ct ≤ Cp/2.5 8 h/24 h - Ct ≤ Cp/3.2 8 h/24 h - Ct ≤ Cp/4 (Cd: motor starting torque)					
Tightening torque of screws (1) and (2) *		Nm	20	20	20	20	20	20	44	

\*: stopped with normal glue



# SIME Brakes Industrial Braking Systems

## Disc Couplings

### DISC BRAKE - FLEXIBLE DISC COUPLING SVKL AND SDKL

Revision number: T10152-01-E

Revision date: 07.03.2019

Flexible couplings series **SVKL** and **SDKL**

Long hub on motor side

Ventilated Discs thickness : **30 mm**

Disc mounting and dismounting without moving the machines back

- Rubber element **V**
  - Rubber element **D**
- (specify type of rubber element with order)

**Option:**

- Solid disc

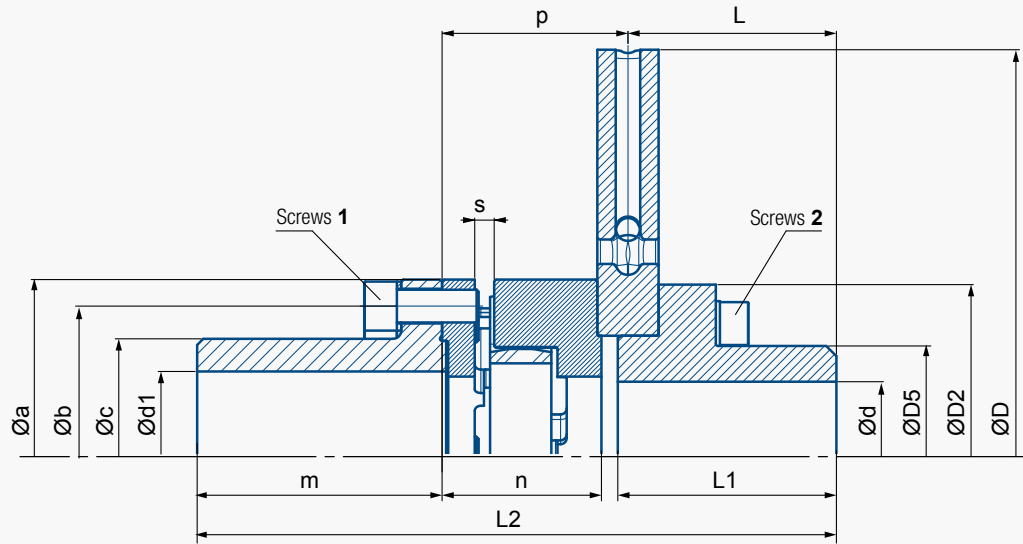

Degrease faces in contact between disc and coupling.

Flexible couplings SVKL / SDKL		125	145		170		200	230				
Disc diameter (th. 30)		315	315	355	395	445	445	495	550			
<b>ASSEMBLY</b>	<b>J with ventilated disc</b>	kg.m <sup>2</sup>	0.17	0.18	0.27	0.42	0.68	0.73	1.2	1.74		
	<b>J with solid disc</b>	kg.m <sup>2</sup>	0.26	0.27	0.41	0.66	1.04	1.09	1.22	2.68		
	Max. weight bored	kg	27	31	37	48	57	63	96	107		
	Maximum speed	r.p.m.	3000	3000	2700	2400	2100	2100	1800	1800		
L2		mm	286.5	298	298	331.5	364.5	364.5	412.5	412.5		
<b>DISC</b>	ØD	mm	315	315	355	395	445	445	495	550		
	ØD2	mm	125	125	145	165	175	175	220	220		
	ØD5	mm	80	80	95	105	110	110	150	150		
	Ød max keyed or shrink fit	mm	50	50	60	70	70	70	100	100		
<b>COUPLING</b>	L	mm	102	102	102	102	135	135	135	135		
	L1	mm	107	107	107	107	140	140	140	140		
	Øa	mm	125	145	145	170	170	200	230	230		
	Øb	mm	105	125	125	144	144	165	190	190		
	Øc	mm	80	100	100	112	112	126	140	140		
	Ød1 max keyed	mm	55	70	70	80	80	90	100	100		
	m	mm	110.5	110.5		140.5		130.5	169.5			
	n	mm	61	72.5		76		86	95			
	p	mm	76	87.5		91		101	110			
	s	mm	6	6.5		7.5		8.5	9.5			
	Max. torque	Rubber element	V	630	1050	1050	1660	1660	2880	4500	4500	
Tk <sub>max</sub> in Nm	Rubber element	D	1110	1800	1800	2850	2850	4950	7740	7740		
Transmissible torque (Tk <sub>n</sub> ) (Tk <sub>n</sub> : motor nominal torque)			Tk <sub>n</sub> ≤ Tk <sub>max</sub> /k		k min.	Temperature	k=3	< 40°C	k=4	< 80°C	k=6	≤ 80°C
			Ts < Tk <sub>max</sub>			Rate		≤ 120 starts/h		≤ 240 starts/h		≤ 600 starts/h
Tightening torque *	Screws 1	Nm	48	84	84	204	204	204	285	285		
	Screws 2	Nm	48	48	84	133	204	204	285	285		

\* Screws class 10.9 greased with molybdenum bisulphide grease under the head and in threads.  
Tightening tool dispersion = ±10%

Ts: motor starting torque. In all cases, Ts < Tk<sub>max</sub>

### DISC BRAKE - FLEXIBLE DISC COUPLING SVKL AND SDKL

Revision number: T10152-01-E

Revision date: 07.03.2019

Flexible couplings series **SVKL** and **SDKL**

Long hub on motor side

Ventilated Discs thickness : **30 mm**

Disc mounting and dismounting without moving the machines back

- Rubber element **V**
  - Rubber element **D**
- (specify type of rubber element with order)

Option:

- Solid disc

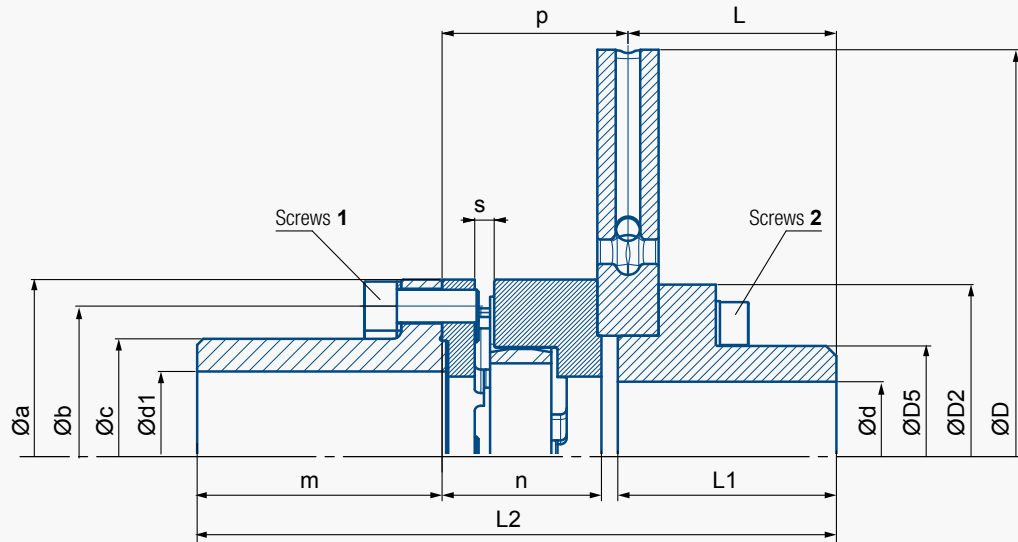

Degrease faces in contact between disc and coupling.

Flexible couplings SVKL / SDKL			260			300			400			
Disc diameter (th. 30)			550	625	705	625-2	705	705-2	795	705	795	
<b>ASSEMBLY</b>	<b>J with ventilated disc</b>	kg.m <sup>2</sup>	1.97	2.77	4.66	4.52	5.09	5.23	7.86	7.44	10.21	
	<b>J with solid disc</b>	kg.m <sup>2</sup>	2.91	4.22	6.89	5.23	7.32	7.81	11.44	9.67	13.79	
	Max. weight bored	kg	120	140	170	185	215	229.5	250	300	356	
	Maximum speed	r.p.m.	1800	1500	1300	1500	1300	1300	1200	1300	1200	
	L2	mm	469	469	469	480	480	480	480	576.5	576.5	
<b>DISC</b>	ØD	mm	550	625	705	625	705	705	795	705	795	
	ØD2	mm	220	235	265	300	265	300	300	265	300	
	ØD5	mm	150	150	180	210	180	210	210	180	210	
	Ød max keyed or shrink fit	mm	100	100	120	130	120	130	130	120	130	
<b>COUPLING</b>	L	mm	135	135	135	135	135	135	135	135	135	
	L1	mm	140	140	140	140	140	140	140	140	140	
	Øa	mm	260	260	260	300	300	300	300	400	400	
	Øb	mm	220	220	220	260	260	260	260	335	335	
	Øc	mm	168	168	168	190	190	190	190	240	240	
	Ød1 max keyed	mm	120	120	120	125	125	125	125	150	150	
	m	mm	209.5			209.5			289.5			
	n	mm	111.5			122.5			139			
	p	mm	126.5			137.5			154			
	s	mm	9.5			10.5			10.5			
Max. torque	Rubber element	V	7200	7200	7200	10400	10400	10400	10400	23400	23400	
Tk <sub>max</sub> in Nm	Rubber element	D	11940	11940	11940	17550	17550	17550	17550	30360	39700	
Transmissible torque (Tk <sub>n</sub> ) (Tk <sub>n</sub> : motor nominal torque)			Tk <sub>n</sub> ≤ Tk <sub>max</sub> /k		k min.	Temperature	k=3	< 40°C	k=4	< 80°C	k=6	≤ 80°C
			Ts < Tk <sub>max</sub>			Rate	≤ 120 starts/h		≤ 240 starts/h		≤ 600 starts/h	
Tightening torque *	Screws 1	Nm	541	541	541	685	685	685	685	1364	1364	
	Screws 2	Nm	285	398	541	541	541	685	685	541	685	

\* Screws class 10.9 greased with molybdenum bisulphide grease under the head and in threads.  
Tightening tool dispersion = ±10%

Ts: motor starting torque. In all cases, Ts < Tk<sub>max</sub>

# SIME Brakes Industrial Braking Systems

## Disc Couplings

### ELASTIC COUPLINGS

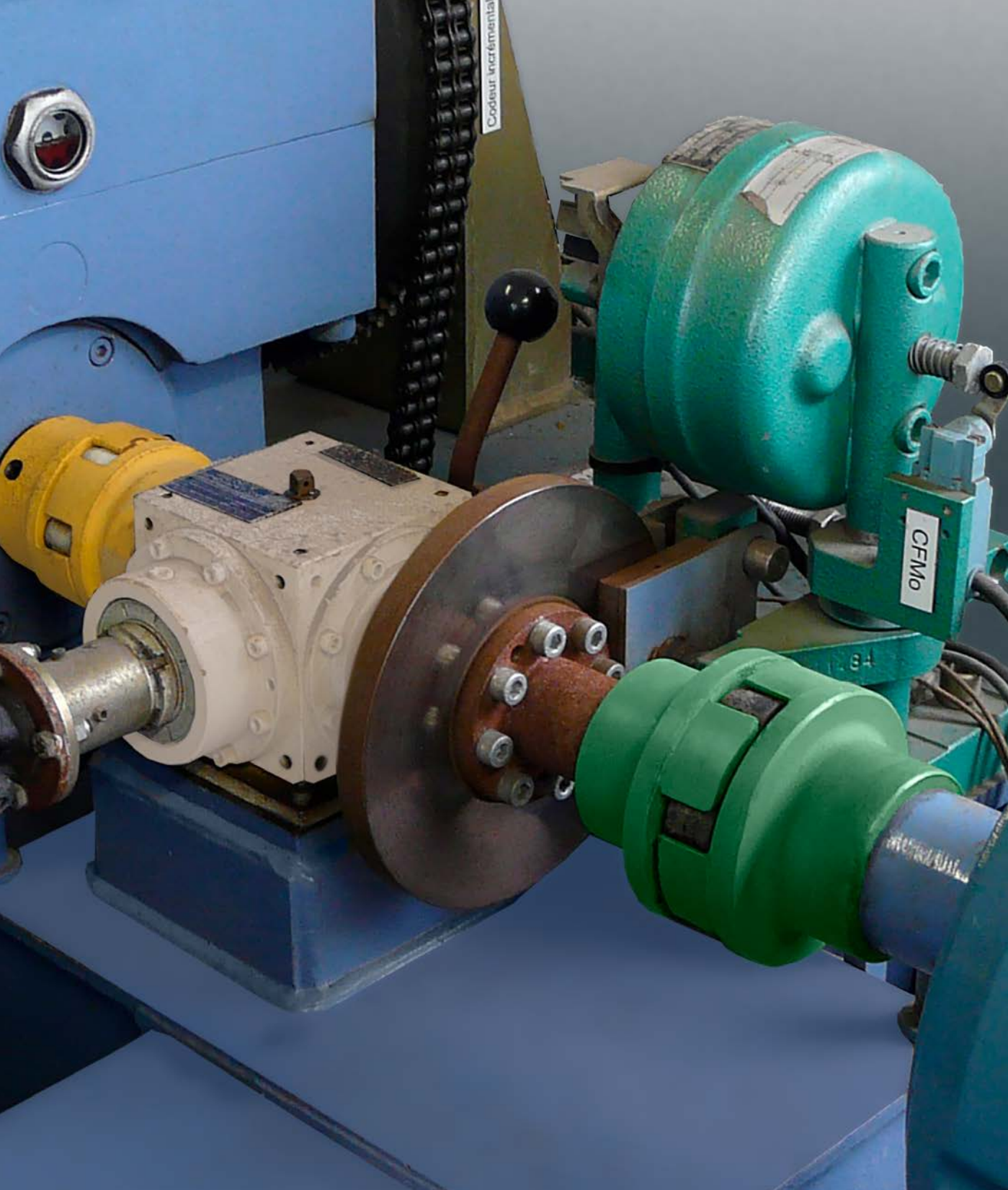

### DISC BRAKE - SVW & SDW ELASTIC COUPLINGS

Revision number: T10156-01-B

Revision date: 12.12.2019

- Cam ring **V**
- Cam ring **D**  
(Specify type of cam ring with order)
- Working temperature : -25°C to +80°C

**Option:**  
 Long hub (motor or/and gearbox side)  
 Short hub (motor or/and gearbox side)  
 Consult us.

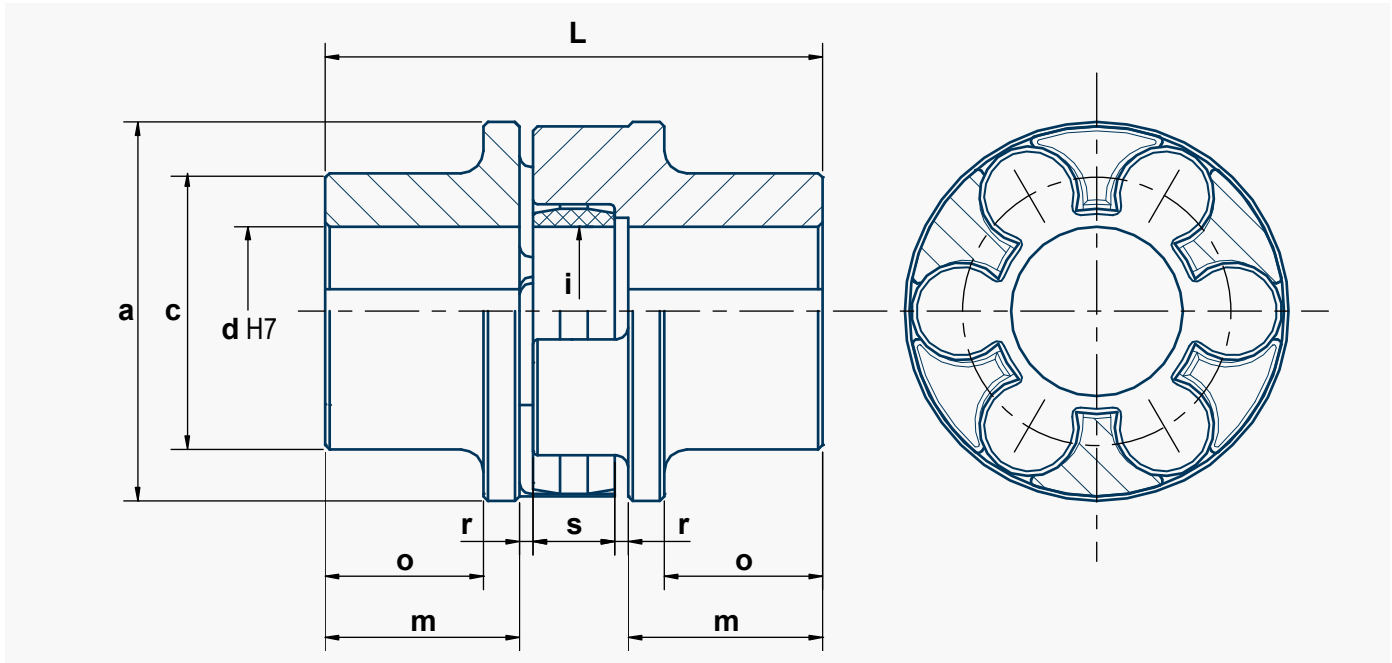

Coupling size SVW- / SDW-			50	70	85	100	125	145	170	200	230	260	300	400
Cam ring n°	<b>SVW</b>		50V	70V	85V	100V	125V	145V	170V	200V	230V	260V	300V	400V
	<b>SDW</b>				85D	100D	125D	145D	170D	200D	230D	260D	300D	400D
Qty of cams			4	6	6	6	6	6	8	8	10	10	10	14
Nominal torque <b>T<sub>CN</sub></b>	<b>SVW</b>	Nm	15	55	90	160	300	480	760	1150	2060	3180	4680	10680
	<b>SDW</b>	Nm			140	240	440	720	1140	1980	3090	4780	7020	16020
Max. torque <b>T<sub>Cmax</sub></b>	<b>SVW</b>	Nm	40	140	225	390	750	1200	1900	2880	5150	7950	11700	26700
	<b>SDW</b>	Nm			350	610	1110	1800	2850	4950	7740	11940	17550	40050
Max. r.p.m.	tr/mn		9000	7500	7000	5600	5000	5000	4000	3600	3200	2500	2000	1750
Mass moment of inertia	kgm <sup>2</sup>		0,0002	0,001	0,002	0,005	0,010	0,021	0,047	0,108	0,195	0,385	0,735	1,852
Weight	kg		0,68	1,64	2,5	4,5	7	9,5	16	27,5	40	57	84	133
Diameters	<b>a</b>	mm	50	70	85	105	126	145	170	200	230	260	300	400
	<b>c</b>	mm	42	55	62	72	88	90	112	125	140	150	200	225
	<b>d</b> pilot bored.	mm	-	-	-	15	20	20	25	25	35	35	40	40
	<b>d</b> max.	mm	24	32	42	48	60	65	75	90	100	105	140	160
	<b>i</b>	mm	19	29	38	46	56	63	90	102	117	140	162	250
Lengths	<b>L</b>	mm	75	100	110	125	145	160	190	245	270	285	330	400
	<b>m</b>	mm	29,5	38,5	43	49	56	60,5	74,5	98,5	110	112,5	131,5	163,5
	<b>o</b>	mm	23,5	31,5	35	37,5	44	46,5	56,5	77,5	87	87,5	106,5	127,5
	<b>s</b>	mm	12	18	18	20	25	30	30	35	35	45	50	55
	<b>r</b>	mm	2	2,5	3	3,5	4	4,5	5,5	6,5	7,5	7,5	8,5	9

# SIME Brakes Industrial Braking Systems







## Cardan Shafts

# CARDAN SHAFTS



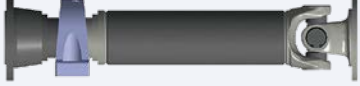

MAIN CHARACTERISTICS	ADVANTAGES
<ul style="list-style-type: none"> <li>TRANSMISSION OF AN ANGULAR ROTATION</li> <li>COUPLING OF 2 ROTATING NON-ALIGNED SHAFTS</li> </ul>	<ul style="list-style-type: none"> <li>MAINTENANCE FREE - do not need lubrication</li> <li>FEWER FAILURES - closed system without loss of grease and without penetration of water and dirt</li> <li>LONG SERVICE LIFE - SAE or involute splines: optimization in accordance with size and utilization of the cardan shaft</li> </ul>

Type	Design	Description
ACS-100		With length compensation
ACS-105		With length compensation in double-flange design
ACS-110		Short couple shaft
ACS-130		Tube shaft without length compensation
ACS-135		Tube shaft without length compensation in double-flange design
ACS-160		Intermediate shaft
ACS-220		Intermediate tube shaft

**L1** = compressed length  
**L2** = maximum possible length compensation  
**Lw max.** = maximum possible working length  
 Optimal working length = **Lw opt.** = **L1 + ½ L2**

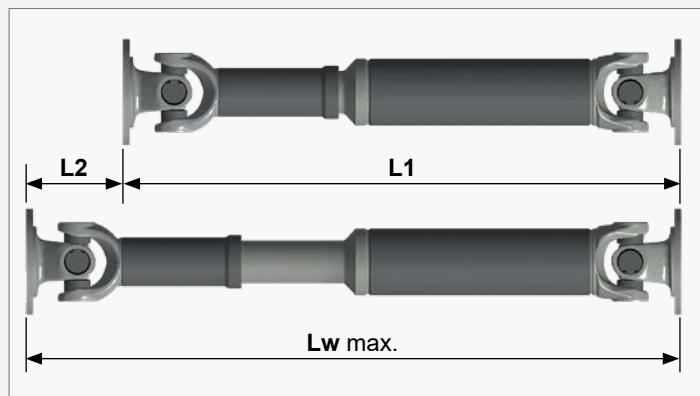

## Cardan Shafts

### ACCESSORIES - CARDAN SHAFTS TYPE ACS

Revision number: T10155-01-B

Revision date: 05.11.2018

Cardan Shaft Sizes





Size	Swing diameter mm	Bearing torque Nm	Feature
1	up to 76	up to 600	One-piece bearing yokes Length compensation with involute spline Flange yoke with DIN or SAE connection
2	100 - 144	1.400 - 6.000	One-piece bearing yokes Length compensation with involute spline Flange yoke with DIN, SAE or cross-serrated connection Maintenance-free U-joints
3	158 - 204	8.800 - 20.000	One-piece bearing yokes Length compensation with involute spline or straight flank spline (SAE) Application-related spline coating Flange yoke with DIN, SAE or cross-serrated connection, as well as with face key Maintenance-free U-joints
4	220 - 315	26.000 – 143.000	One-piece bearing yokes Length compensation with involute spline or straight flank spline (SAE) Application-related spline coating Flange yoke with DIN, face key or Hirth-serration Maintenance-free U-joints
5	350 - 620	210.000 – 1.250.000	One-piece bearing yokes Length compensation with involute spline or straight flank spline (SAE) Application-related spline coating Flange yoke with DIN, face key or Hirth-serration Double flange design
6	from 680	from 1.950.000	One-piece bearing yokes Length compensation with straight flank spline (SAE) Application-related spline coating Flange yoke with face key or Hirth-serration Double flange design

### ACCESSORIES - CARDAN SHAFTS TYPE ACS

Revision number: T10155-01-B

Revision date: 05.11.2018

Series 1, 2 and 3

Series		1	2				3					
Size		07600	10000	11600	12600	14400	15800	17200	17800	20400		
DESIGN	Bearing Torque	Nm	600	1.400	3.000	5.300	6.000	8.800	12.500	17.000	20.000	
	Reversing Fatigue Torque	Nm	300	700	1.500	2.300	2.900	4.400	5.100	8.500	11.000	
	Joint Performance Factor	Nm	220	660	990	1.780	2.070	2.400	3.500	4.600	6.800	
	Swing Diameter	mm	76	100	116	126	144	158	172	178	204	
	 <b>100</b>	L1 min		250	421	451	536	572	630	566	661	746
		L2 min		40	110	110	110	110	180	110	110	110
		tube size		50	50 / 76,2	70 / 90	90	100	100	120	120	140
	 <b>110</b>	L1 min		214	240	290	340	409	400	430	450	480
		L2 min		15	15	30	40	45	35	40	40	40
		L1 max		249	420	450	535	571	559	565	660	745
		L2 max		40	110	110	110	110	110	110	110	110
	 <b>130</b>	L1 min		190	218	278	309	369	355	400	353	440
		tube size		50	50 / 76,2	70 / 90	90	100	120	120	120	140
CONNECTIONS (ØD-N-Ød)	<b>DIN</b> 	75-6-6	90-4-8	100-6-8	120-8-10	150-8-12	150-8-12	180-8-14	180-8-14	180-8-14	180-8-14	
		90-4-8	100-6-8	120-8-8	150-8-12	180-8-14	180-8-14	180-8-16	180-8-16	180-8-16	180-8-16	
			100-8-8	120-8-10	180-8-10		180-8-16	180-10-16	180-10-16	180-10-16	180-10-16	
			120-8-8	150-8-10	180-8-14		180-10-16	225-8-16	225-8-16	225-8-16	225-8-16	
			120-8-10	150-8-12					250-8-18	250-8-18	250-8-18	
	<b>SAE</b> 	87-4-8	87-4-8	119-4-11,1	146-4-12,7	174,8-8-9,6	174,8-8-9,6	203,2-8-9,6	203,2-8-9,6	203,2-12-11,1	203,2-12-11,1	
			96,8-4-9,6	149-4-12,7			203,2-8-9,6	203,2-12-11,1	203,2-12-11,1	203,2-12-11,1	244,5-8-16,1	
			119-4-11,1				203,2-12-11,1					
	<b>Cross serration</b> 		100-4-8,5	122-4-11	122-4-11	122-4-11	150-4-13	150-4-13	150-4-13	150-4-13	180-4-15	
			122-4-11				150-4-13	180-4-15	180-4-15	180-4-15		

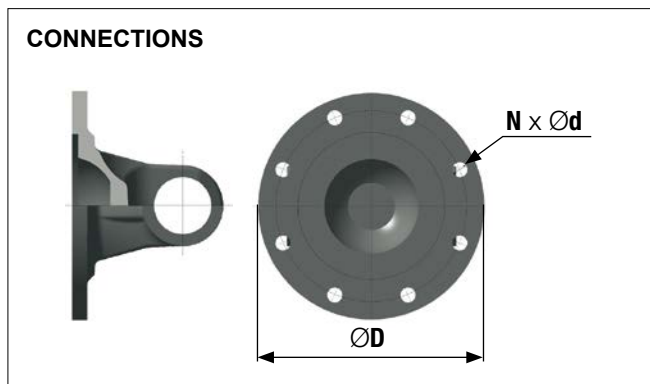

# SIME Brakes Industrial Braking Systems

## Cardan Shafts

### ACCESSORIES - CARDAN SHAFTS TYPE ACS

Revision number: T10155-01-B

Revision date: 05.11.2018

Series 4 and 5



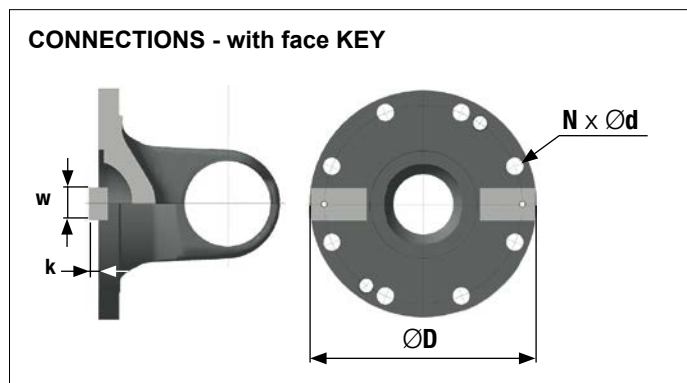

Series		4					5					
Size		21500	21510	22580	25080	28580	31510	35000	39000	44000		
DESIGN	Bearing Torque	Nm	26.000	29.000	45.000	70.000	100.000	143.000	210.000	300.000	500.000	
	Reversing Fatigue Torque	Nm	13.000	14.500	23.000	35.000	50.000	70.000	100.000	150.000	250.000	
	Joint Performance Factor	Nm	8.050	8.350	12.050	18.650	26.200	28.140	40.300	56.800	81.500	
	Swing Diameter	mm	220	220	225	250	285	315	350	390	440	
		L1 min	797	775	900	995	1.115	1.205	1.295	1.450	1.660	
		L2 min	150	140	110	140	140	140	150	170	190	
		tube size	144	150	160 / 170	180	200	219	245	273	325	
		L1 min	551	580	585	645	990	980	1.175	1.140	1.300	
		L2 min	50	40	40	40	50	100	50	80	70	
		L1 max	796	650	899	994	1.114	1.204	1.294	1.449	1.659	
		L2 max	150	110	140	140	140	140	150	170	190	
		L1 min	506	538	615	680	760	890	950	1.040	1.250	
		tube size	144	150	160 / 170	180	200	215	245	273	324	
	CONNECTIONS (ØD-N-Ød)		DIN	225-8-16	225-8-16	225-8-16	250-8-18	285-8-20	315-8-22	350-10-22	390-10-24	435-10-27
				250-8-18	250-8-18	250-8-18	285-8-20	315-8-22	350-10-22	390-10-24	435-10-27	
			285-8-20	285-8-20	285-8-20	315-8-22						
		DIN with face key (w x k)	225-8-17 (32x9)	225-8-17 (32x9)	225-8-17 (32x9)	250-8-19 (40x12)	285-8-21 (40x15)	315-10-23 (40x15)	350-10-23 (50x16)	390-10-25 (70x18)	435-16-28 (80x20)	
				250-8-19 (40x12,5)	250-8-19 (40x12,5)	285-8-21 (40x15)	315-10-23 (40x15)	350-10-23 (50x16)	390-10-25 (70x18)	435-16-28 (80x20)	480-16-31 (90x22,5)	
					285-8-21 (40x15)							
		High-serration							350-12-1116	390-12-1118	435-16-1118	
									390-12-1118	435-16-1118	480-16-1120	



### ACCESSORIES - CARDAN SHAFTS TYPE ACS

Revision number: T10155-01-B

Revision date: 05.11.2018

Series		5		6				
Size		49000	55000	62000	68000	75000	84000	
DESIGN	Bearing Torque	Nm	700.000	1.000.000	1.250.000	1.950.000	2.650.000	3.900.000
	Reversing Fatigue Torque	Nm	345.000	500.000	625.000	950.000	1.350.000	1.850.000
	Joint Performance Factor	Nm	112.000	154.000	210.000	320.000	750.000	2.230.000
	Swing Diameter	mm	490	550	620	680	750	840
	 <b>100</b>	L1 min		1.810	1.965	2.240		
		L2 min		190	240	250		
		tube size		351	402	445		
	 <b>110</b>	L1 min		1.300	1.770	2.050		
		L2 min		50	55	55		
		L1 max		1.809	1.964	2.239		
		L2 max		190	240	250		
	 <b>130</b>	L1 min		1.360	1.480	1.690		
		tube size		355	406	445		
	 <b>105</b>	L1 min				3.250	4.000	4.250
		L2 min				250	250	250
		tube size				559	609	660
 <b>135</b>	L1 min				1.950	2.400	2.700	
	tube size				559	609	660	
CONNECTION (ØD-N-Ød)	DIN with face key (w x k)		480-16-31 (90x22,5)	550-16-31 (100x22,5)	620-16-38 (100x25)			
			550-16-31 (100x22,5)	620-16-38 (100x25)				
	High- serration		480-16-1120	550-11-1122	620-6	680-24-33	750-24-33	840-24-38
			550-16-24	620-24-26	680-24-33			

# SIME Brakes Industrial Braking Systems

## Hydraulic Buffers

### HYDRAULIC BUFFERS

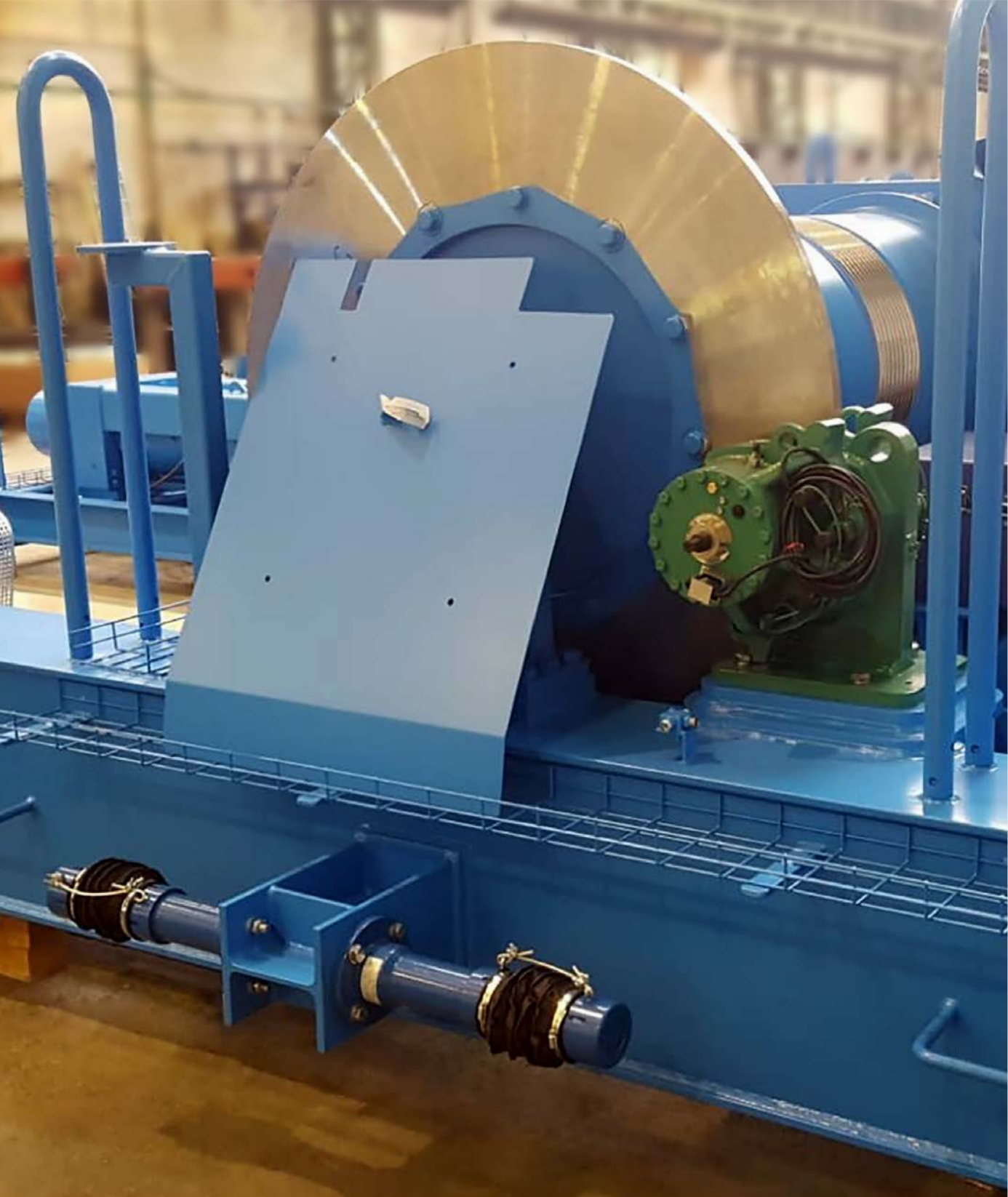

# SIME Brakes Industrial Braking Systems

## Hydraulic Buffers

MAIN CHARACTERISTICS	APPLICATIONS
<ul style="list-style-type: none"> <li>• DAMPING DEVICES REQUIRING NO EXTERNAL ENERGY</li> <li>• DECELERATE MOVING MACHINES ALONG THE SHORTEST POSSIBLE PATH</li> <li>• SELF-ADJUSTMENT</li> <li>• 2 TYPES: REAR MOUNTING OR FRONT MOUNTING</li> <li>• FILLING: OIL / NITROGEN</li> </ul>	<ul style="list-style-type: none"> <li>• STEEL INDUSTRY</li> <li>• NUCLEAR CRANES</li> <li>• PORT APPLICATIONS</li> <li>• OVERHEAD CRANES - CONTAINER CRANES STACKER CRANES</li> <li>• TRANSFER CARS - RAILWAY APPLICATIONS</li> </ul>

Coating & Options	
<b>Temperature</b>	-10 C à +80 C (standard) -40 C à +120 C (special)
<b>Piston rod</b>	Plasma coating (20 µ)
<b>Body coating</b>	Synthetic resin Color 80µM - standard: RAL5009 (Azure blue)
<b>Options</b>	Body coating: RAL1003 (signal yellow) RAL3020 (traffic red) RAL7021 (black grey) RAL9011 (graphite black) Safety chain Protection cover



With the options: safety chain and protection cover

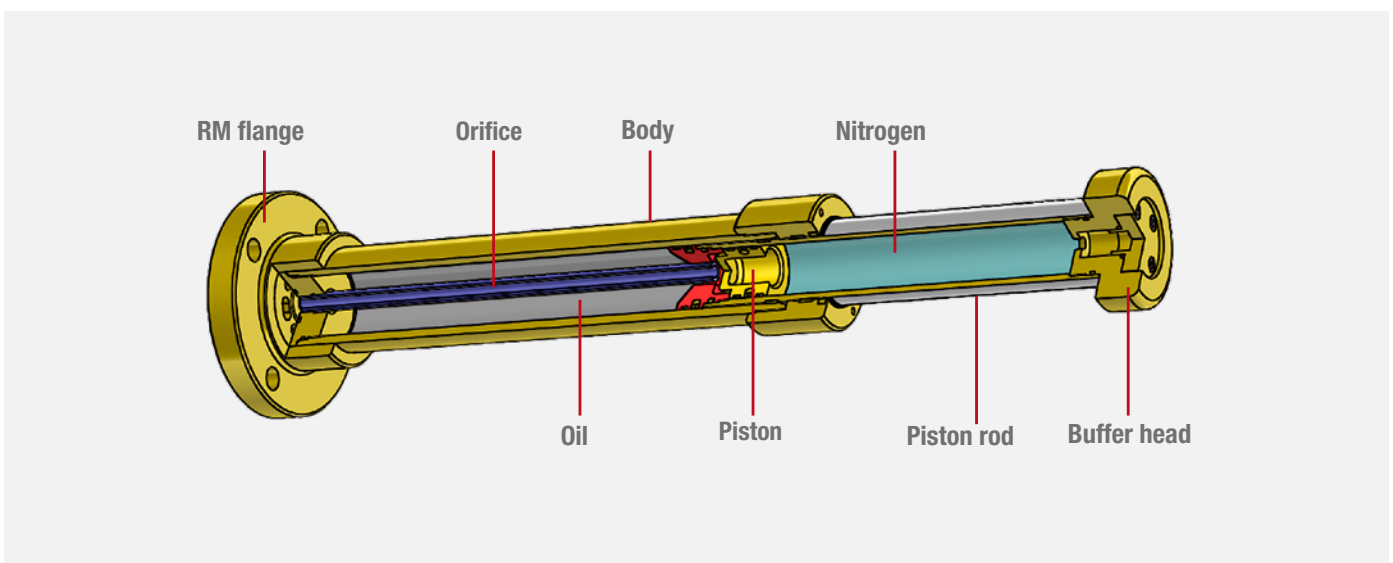

# SIME Brakes Industrial Braking Systems

## Hydraulic Buffers

### ACCESSORIES - HYDRAULIC BUFFERS

Revision number: T10125-01-D

Revision date: 20.09.2019

PHS 063

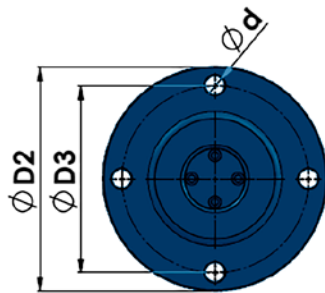
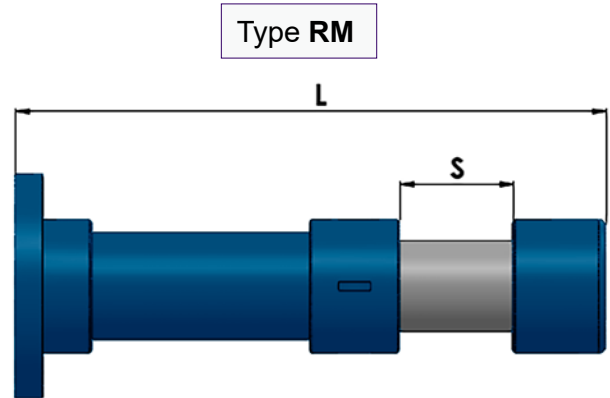
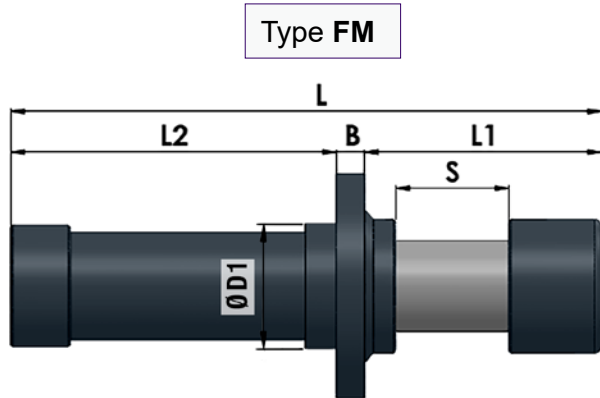

**PHS 063 100-RM**

Size    Stroke    Type

Dimensions in mm	S	L	L1	L2	B	D1	D2	D3	d	W (kJ) Capacity/Stroke	F (kN) Buffering Force
<b>PHS 063 100</b>	100	455,5	202	233,5	20	91	168	135	17	15	170
<b>PHS 063 150</b>	150	568	252	296	20	91	168	135	17	23	170
<b>PHS 063 200</b>	200	680,5	302	358,5	20	91	168	135	17	30	170
<b>PHS 063 250</b>	250	793	352	421	20	91	168	135	17	38	170
<b>PHS 063 300</b>	300	905,5	402	483,5	20	91	168	135	17	46	170
<b>PHS 063 350</b>	350	1018	452	546	20	91	168	135	17	51	160
<b>PHS 063 400</b>	400	1130,5	502	608,5	20	91	168	135	17	54	150
<b>PHS 063 450</b>	450	1243	552	671	20	91	168	135	17	57	140
<b>PHS 063 500</b>	500	1355,5	602	733,5	20	91	168	135	17	59	130
<b>PHS 063 550</b>	550	1468	652	796	20	91	168	135	17	60	120
<b>PHS 063 600</b>	600	1580,5	702	858,5	20	91	168	135	17	60	110
<b>PHS 063 650</b>	650	1693	752	921	20	91	168	135	17	59	100
<b>PHS 063 700</b>	700	1805,5	802	983,5	20	91	168	135	17	57	90
<b>PHS 063 750</b>	750	1918	852	1046	20	91	168	135	17	54	80
<b>PHS 063 800</b>	800	2030,5	902	1108,5	20	91	168	135	17	51	70



### ACCESSORIES - HYDRAULIC BUFFERS

Revision number: T10125-01-D

Revision date: 20.09.2019

PHS 080

Type FM

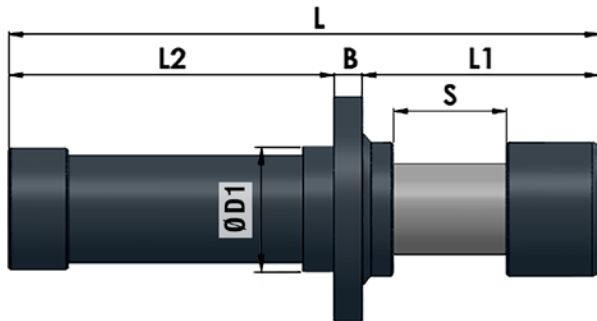

Type RM

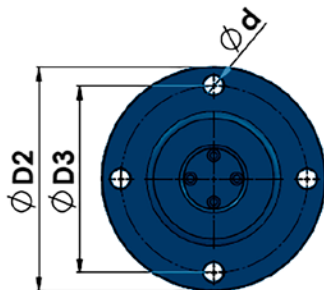
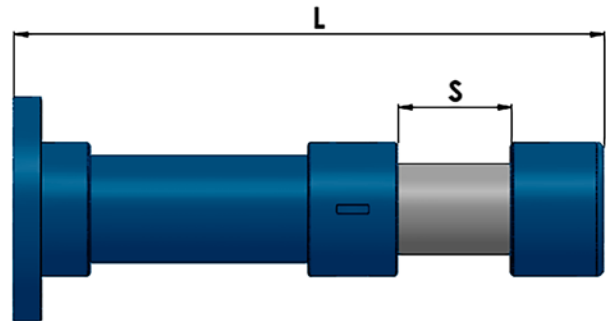

PHS 080 100-RM  
 Size Stroke Type

Dimensions in mm	S	L	L1	L2	B	D1	D2	D3	d	W (kJ) Capacity/Stroke	F (kN) Buffering Force
PHS 080 100	100	522,5	209,5	288	25	110	198	165	17	23	260
PHS 080 150	150	635	259,5	350,5	25	110	198	165	17	35	260
PHS 080 200	200	747,5	309,5	413	25	110	198	165	17	48	260
PHS 080 250	250	860	359,5	475,5	25	110	198	165	17	59	260
PHS 080 300	300	972,5	409,5	538	25	110	198	165	17	68	250
PHS 080 350	350	1085	459,5	600,5	25	110	198	165	17	76	240
PHS 080 400	400	1197,5	509,5	663	25	110	198	165	17	84	230
PHS 080 450	450	1310	559,5	725,5	25	110	198	165	17	90	220
PHS 080 500	500	1422,5	609,5	788	25	110	198	165	17	95	210
PHS 080 550	550	1535	659,5	850,5	25	110	198	165	17	100	200
PHS 080 600	600	1647,5	709,5	913	25	110	198	165	17	104	190
PHS 080 650	650	1760	759,5	975,5	25	110	198	165	17	106	180
PHS 080 700	700	1872,5	809,5	1038	25	110	198	165	17	108	170
PHS 080 750	750	1985	859,5	1100,5	25	110	198	165	17	109	160
PHS 080 800	800	2097,5	909,5	1163	25	110	198	165	17	109	150

# SIME Brakes Industrial Braking Systems

## Hydraulic Buffers

### ACCESSORIES - HYDRAULIC BUFFERS

Revision number: T10125-01-D

Revision date: 20.09.2019

PHS 100

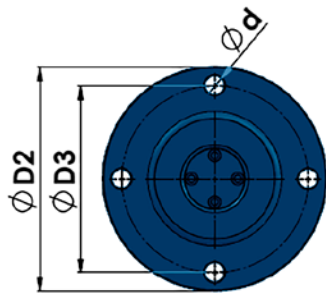
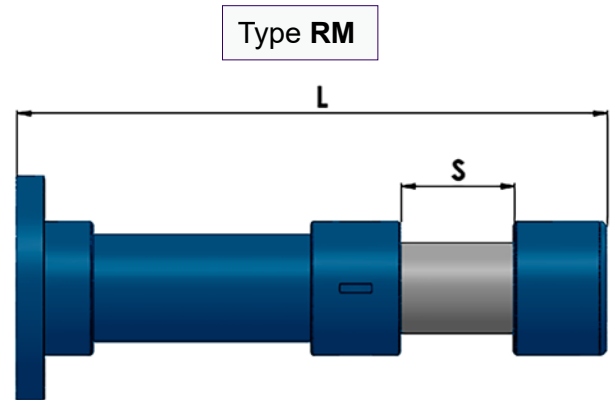
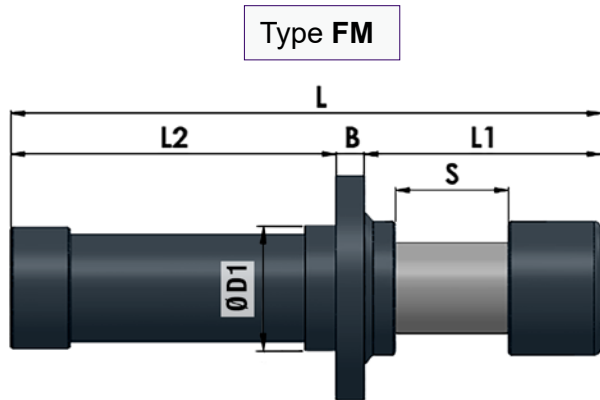

PHS **100** **100**-**RM**  
 Size Stroke Type

Dimensions in mm	S	L	L1	L2	B	D1	D2	D3	d	W (kJ) Capacity/Stroke	F (kN) Buffering Force
<b>PHS 100 100</b>	100	538,5	207	301,5	30	132	258	210	23	38	420
<b>PHS 100 150</b>	150	651	257	364	30	132	258	210	23	58	420
<b>PHS 100 200</b>	200	763,5	307	426,5	30	132	258	210	23	78	420
<b>PHS 100 250</b>	250	876	357	489	30	132	258	210	23	98	420
<b>PHS 100 300</b>	300	988,5	407	551,5	30	132	258	210	23	115	420
<b>PHS 100 350</b>	350	1101	457	614	30	132	258	210	23	132	420
<b>PHS 100 400</b>	400	1213,5	507	676,5	30	132	258	210	23	148	410
<b>PHS 100 450</b>	450	1326	557	739	30	132	258	210	23	161	400
<b>PHS 100 500</b>	500	1438,5	607	801,5	30	132	258	210	23	175	390
<b>PHS 100 550</b>	550	1551	657	864	30	132	258	210	23	190	380
<b>PHS 100 600</b>	600	1663,5	707	926,5	30	132	258	210	23	200	370
<b>PHS 100 650</b>	650	1776	757	989	30	132	258	210	23	210	360
<b>PHS 100 700</b>	700	1888,5	807	1051,5	30	132	258	210	23	220	350
<b>PHS 100 750</b>	750	2001	857	1114	30	132	258	210	23	230	340
<b>PHS 100 800</b>	800	2113,5	907	1176,5	30	132	258	210	23	240	330

### ACCESSORIES - HYDRAULIC BUFFERS

Revision number: T10125-01-D

Revision date: 20.09.2019

PHS 125

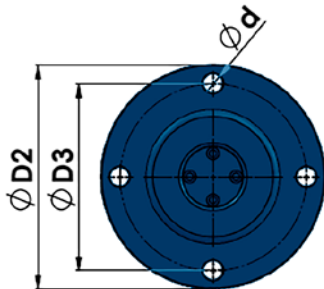
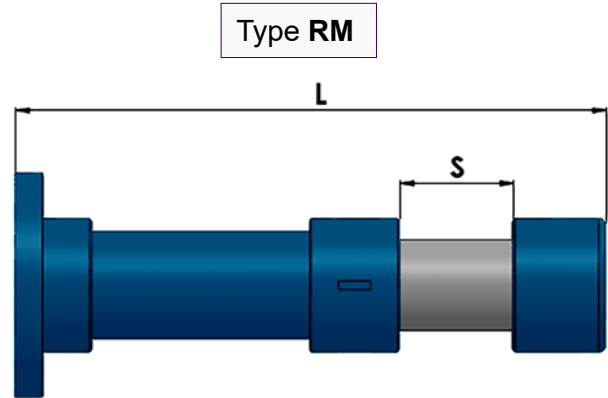
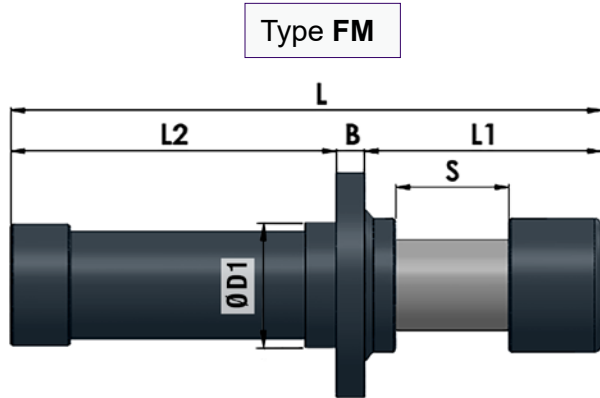

**PHS 125 100-RM**  
 Size Stroke Type

Dimensions in mm	S	L	L1	L2	B	D1	D2	D3	d	W (kJ) Capacity/Stroke	F (kN) Buffering Force
<b>PHS 125 100</b>	100	528,5	204,5	289	35	167	300	245	27	60	670
<b>PHS 125 150</b>	150	641	254,5	351,5	35	167	300	245	27	91	670
<b>PHS 125 200</b>	200	753,5	304,5	414	35	167	300	245	27	121	670
<b>PHS 125 250</b>	250	866	354,5	476,5	35	167	300	245	27	154	670
<b>PHS 125 300</b>	300	978,5	404,5	539	35	167	300	245	27	185	670
<b>PHS 125 350</b>	350	1091	454,5	601,5	35	167	300	245	27	215	670
<b>PHS 125 400</b>	400	1203,5	504,5	664	35	167	300	245	27	248	670
<b>PHS 125 450</b>	450	1316	554,5	726,5	35	167	300	245	27	275	650
<b>PHS 125 500</b>	500	1428,5	604,5	789	35	167	300	245	27	301	650
<b>PHS 125 550</b>	550	1541	654,5	851,5	35	167	300	245	27	325	630
<b>PHS 125 600</b>	600	1653,5	704,5	914	35	167	300	245	27	351	630
<b>PHS 125 650</b>	650	1766	754,5	976,5	35	167	300	245	27	377	630
<b>PHS 125 700</b>	700	1878,5	804,5	1039	35	167	300	245	27	393	610
<b>PHS 125 750</b>	750	1991	854,5	1101,5	35	167	300	245	27	414	610
<b>PHS 125 800</b>	800	2103,5	904,5	1164	35	167	300	245	27	435	590

# SIME Brakes Industrial Braking Systems

## Barrel-Roller Couplings

# BARREL-ROLLER COUPLINGS





### APPLICATIONS

- HOISTING DEVICE OF CRANES AND CONVEYORS INSTALLATIONS
- STEEL INDUSTRY
- HOISTING, GANTRY, STACKER AND CONTAINERS CRANES

### MAIN CHARACTERISTICS

- CONNECT THE SLOW ROTATING SHAFT OF A GEARBOX TO THE ROPE DRUM OF HOISTING INSTALLATIONS
- CANCEL ALL THE CONSEQUENTIAL DISADVANTAGE OF A RIGID CONNECTION
- COMPENSATION OF ANGULAR AND AXIAL MISALIGNMENT

### BCS COUPLINGS

- All-steel design
- Connection between hub and sleeve performed by barrel rollers
- Possibility to disassemble the hub from the sleeve
- Roller seats, inside the sleeve, are precisely machined and hardened

### Benefits include

- Consent elevated radial loads proper to the rope drum of a hoisting crane
- Easy mounting :
  - hub fitted on the shaft of the gearbox
  - sleeve bolted directly on the rope drum
  - the 2 parts of the coupling are separately assembled in their axial working position
- Wear minimized

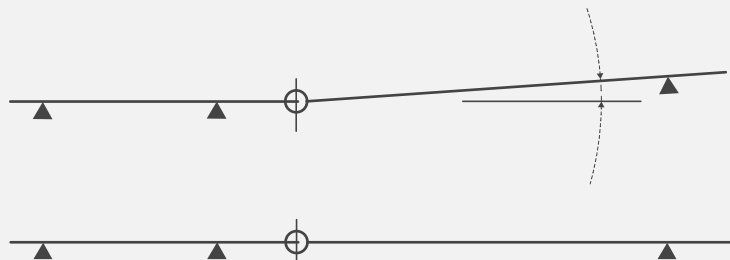
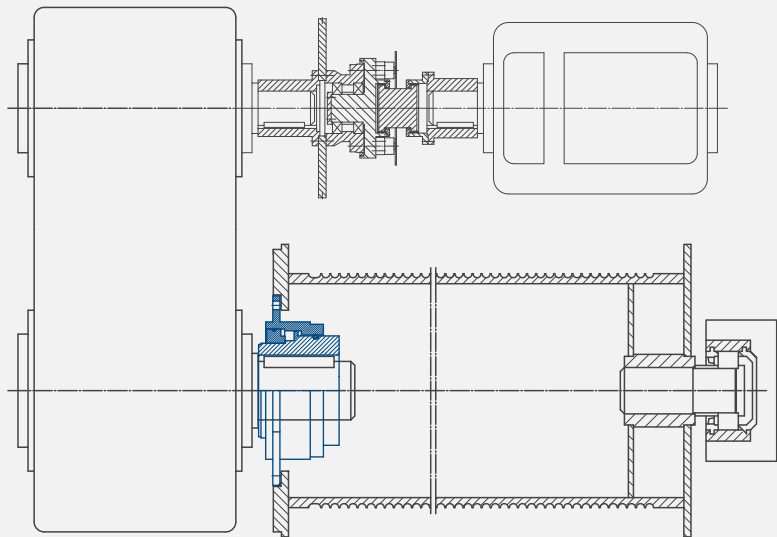

# SIME Brakes Industrial Braking Systems

## Barrel-Roller Couplings

### DRUMS - BARREL-ROLLER COUPLINGS TYPE BCS

Revision number: T10144-01-C

Revision date: 30.05.2018

Steel coupling designed to connect the slow rotating shaft of a gearbox to the rope drum of hoisting equipment.

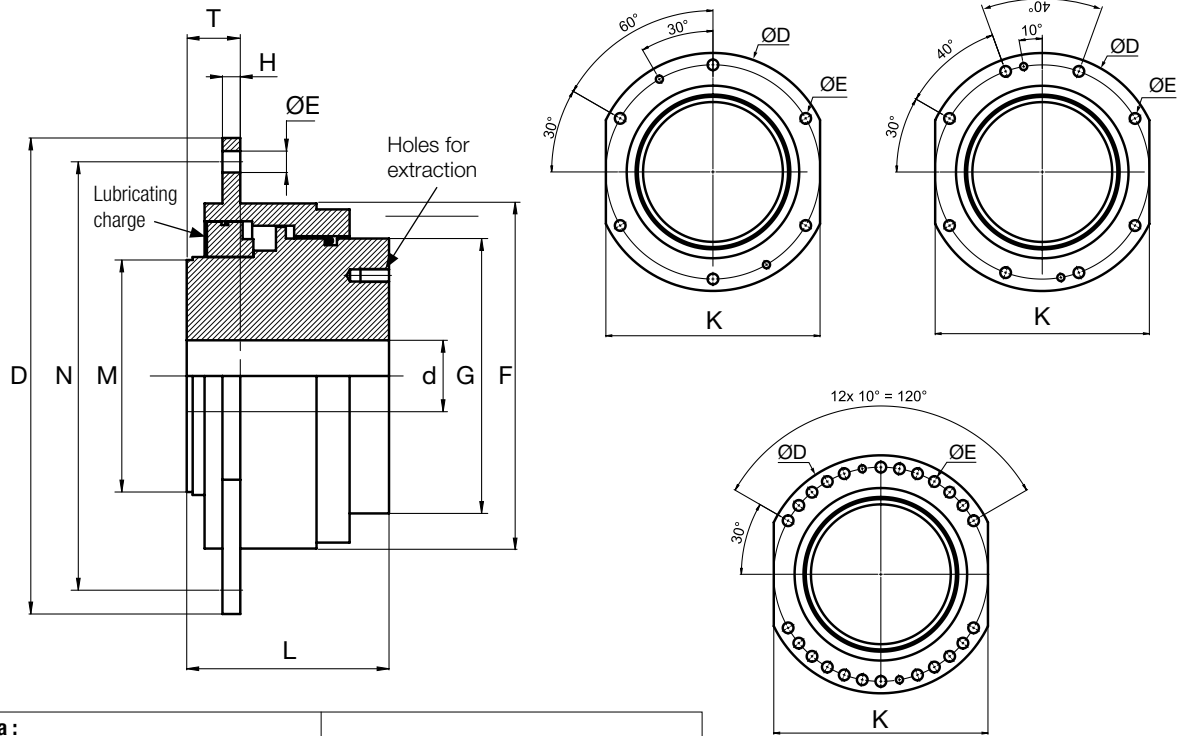

**Nota :**

For bore finishing, reference centering diameter is concentric to barrel rollers pitch circle.

The dimensions **L** are the standard length of the couplings type **BCS**. For different lengths, consult us.

COUPLING type BCS...		140	160	180	200	220	240	260	280	310	340	400	420	450	530	560	600	670	730
Bore <b>d</b> (mm)	pilot	30	30	30	50	50	60	60	60	70	70	90	90	100	100	120	120	140	140
	max	65	80	85	95	105	115	130	140	160	175	210	220	235	290	310	330	375	410
Dimensions (mm)	<b>D</b>	230	250	280	320	340	360	380	400	420	450	510	550	580	650	680	710	780	850
	<b>M</b>	90	110	120	135	145	163	183	195	225	255	310	325	350	425	455	490	555	615
	<b>F h6</b>	140	160	180	200	220	240	260	280	310	340	400	420	450	530	560	600	670	730
	<b>T</b>	42	42	42	45	45	45	45	45	45	60	60	60	60	65	65	81	81	81
	<b>L</b>	90	95	100	110	125	130	145	170	175	185	220	240	260	315	350	380	410	450
	<b>H</b>	12	12	12	15	15	15	15	15	15	20	20	20	20	25	25	25	25	25
	<b>N</b>	200	220	250	280	300	320	340	360	380	400	460	500	530	600	630	660	730	800
	<b>G</b>	110	130	142	157	175	195	215	231	261	286	346	361	386	461	491	526	591	651
	Ø <b>E</b> H8	14	14	14	18	18	18	18	18	18	24	24	24	24	24	24	28	28	28
	N° holes	6	6	6	6	6	6	6	6	6	6	6	6	8	8	24	24	24	24
	<b>K</b> h9	200	220	250	280	300	320	340	360	380	400	460	500	530	580	600	640	700	760
Weight (kg)		13	16	24	29	35	42	54	67	90	108	150	190	230	395	460	520	740	890
Nominal torque max. (daNm)		50	400	780	1350	1600	1850	2200	3200	4000	5100	7700	11250	13000	19000	31000	42000	54000	75000
Radial force (daN)		1200	1400	1800	2500	3100	3700	4200	5200	6300	7950	11250	12300	14500	20200	25000	30000	34000	39000

# Premier Industrial Company Leading Brands

## OTHER PRODUCT SOLUTIONS FROM **ALTRA MOTION**

Our comprehensive product offerings include various types of clutches and brakes, overrunning clutches, engineered bearing assemblies, gearing and gear motors along with linear motion products, belted drives, couplings, limit switches, precision motors, drives & controls, miniature motors and engine braking systems. With thousands of product solutions available, Altra provides true single source convenience while meeting specific customer requirements. Many major OEMs and end users prefer Altra products as their No. 1 choice for performance and reliability.

[WWW.ALTRAMOTION.COM](http://WWW.ALTRAMOTION.COM)



### **Electric Clutches & Brakes**

Inertia Dynamics  
Matrix  
Stromag  
Warner Electric



### **Precision Motors & Automation**

Kollmorgen



### **Heavy Duty Clutches & Brakes**

Industrial Clutch  
Stromag  
Svendborg Brakes  
Twiflex  
Wichita Clutch



### **Miniature Motors**

Portescap



### **Overrunning Clutches**

Formsprag Clutch  
Marland Clutch  
Stieber



### **Linear Systems**

Thomson



### **Engineered Couplings & Universal Joints**

Ameridrives  
Bibby Turboflex  
Guardian Couplings  
Huco  
Lamiflex Couplings  
Stromag  
TB Wood's



### **Engine Braking Systems**

Jacobs Vehicle Systems



### **Gear Drives & Gear Motors**

Bauer Gear Motor  
Boston Gear  
Delroyd Worm Gear  
Nuttall Gear



### **Specialty Components**

Kilian  
Stromag  
TB Wood's

## Stromag Facilities

### Europe

#### Germany

Hansastraße 120  
59425 Unna - Germany  
+49 (0) 23 03 102 0

*Clutches & Brakes, Couplings,  
Geared Cam Limit Switches, Discs,  
Wind Brakes*

Dessauer Str. 10  
06844 Dessau-Roßlau - Germany  
+49 (0) 340 2190 0

*Electromagnetic Clutches & Brakes*

#### France

Avenue de l'Europe  
18150 La Guerche sur L'Aubois - France  
+33 (0)2 48 80 72 72

*Disc Brakes & Drum Brakes*

#### Great Britain

Amphill Road  
Bedford, MK42 9RD - UK  
+44 (0)1234 324347

*Electromagnetic Clutches & Brakes,  
Industrial Caliper Brakes*

### North America

#### USA

31 Industrial Park Road  
New Hartford, CT 06057 - USA  
860-238-4783

*Electromagnetic Clutches & Brakes*

300 Indiana Highway 212  
Michigan City, IN 46360 - USA  
219-874-5248

*Couplings*

2800 Fisher Rd.  
Wichita Falls, TX 76302 - USA  
940-723-3400

*Geared Cam Limit Switches,  
Industrial Caliper & Drum Brakes*

#### South America

#### Brasil

Avenida João Paulo Ablas, 2970  
Jardim da Glória, Cotia - SP,  
06711-250 - Brasil  
+55 (11) 4615-6300

*Flexible Couplings, Bearing  
Isolators, and Coupling Guards*

### Asia Pacific

#### China

T40B -5, No. 1765 Chuan Qiao Road  
Pudong 201206, Shanghai - China  
Tel +86 21-60580600

*Clutches & Brakes, Electromagnetic  
Clutches & Brakes, Couplings, Industrial  
Caliper & Drum Brakes, Discs, Geared  
Cam Limit Switches, Wind Brakes*

#### India

Gat No.: 448/14, Shinde Vasti, Nigohje  
Tal Khed, Pune- 410 501  
+91 2135 622100

*Clutches & Brakes, Electromagnetic  
Clutches & Brakes, Couplings, Industrial  
Caliper & Drum Brakes, Discs, Geared  
Cam Limit Switches, Wind Brakes*

## The Brands of Altra Motion

### Couplings

**Ameridrives**  
www.ameridrives.com

**Bibby Turboflex**  
www.bibbyturboflex.com

**Guardian Couplings**  
www.guardiancouplings.com

**Huco**  
www.huco.com

**Lamiflex Couplings**  
www.lamiflexcouplings.com

**Stromag**  
www.stromag.com

**TB Wood's**  
www.tbwoods.com

### Linear Systems

**Thomson**  
www.thomsonlinear.com

**Warner Linear**  
www.warnerlinear.com

### Geared Cam Limit Switches

**Stromag**  
www.stromag.com

### Engineered Bearing Assemblies

**Kilian**  
www.kilianbearings.com

### Electric Clutches & Brakes

**Matrix**  
www.matrix-international.com

**Stromag**  
www.stromag.com

**Warner Electric**  
www.warnerelectric.com

**Deltran**  
www.thomsonlinear.com

### Belted Drives

**TB Wood's**  
www.tbwoods.com

### Heavy Duty Clutches & Brakes

**Twiflex**  
www.twiflex.com

**Stromag**  
www.stromag.com

**Svendborg Brakes**  
www.svendborg-brakes.com

**Wichita Clutch**  
www.wichitaclutch.com

### Gearing & Specialty Components

**Bauer Gear Motor**  
www.bauergears.com

**Boston Gear**  
www.bostongear.com

**Delevan**  
www.delevan.com

**Delroyd Worm Gear**  
www.delroyd.com

**Nuttall Gear**  
www.nuttallgear.com

### Engine Braking Systems

**Jacobs Vehicle Systems**  
www.jacobsvehiclesystems.com

### Precision Motors & Automation

**Kollmorgen**  
www.kollmorgen.com

### Miniature Motors

**Portescap**  
www.portescap.com

### Overrunning Clutches

**Formsprag Clutch**  
www.formsprag.com

**Marland Clutch**  
www.marland.com

**Stieber**  
www.stieberclutch.com

Neither the accuracy nor completeness of the information contained in this publication is guaranteed by the company and may be subject to change in its sole discretion. The operating and performance characteristics of these products may vary depending on the application, installation, operating conditions and environmental factors. The company's terms and conditions of sale can be viewed at <http://www.altramotion.com/terms-and-conditions/sales-terms-and-conditions>. These terms and conditions apply to any person who may buy, acquire or use a product referred to herein, including any person who buys from a licensed distributor of these branded products.

©2019 by Stromag LLC. All rights reserved. All trademarks in this publication are the sole and exclusive property of Stromag LLC or one of its affiliated companies.