

Svendborg Brakes Range Product Specifications

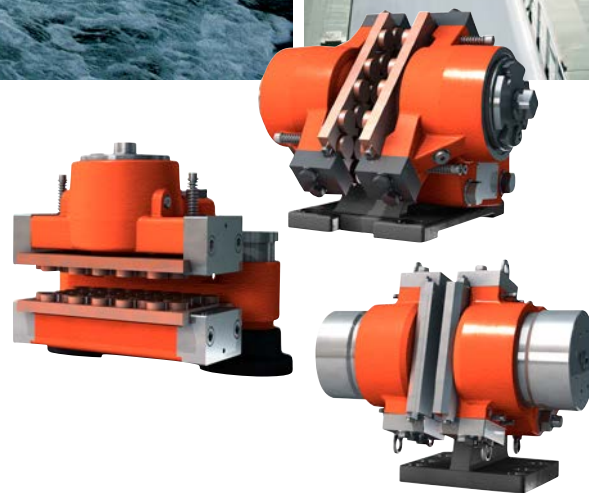

SVENDBORG BRAKES

REGAL REXNORD

Since 1989, Svendborg Brakes has been recognized as a leading global expert in intelligent braking solutions for industrial applications. Extensive application knowledge, innovative design, fast prototyping and exhaustive testing ensures that customers get the most technically advanced, most durable and safest braking systems to meet their specific requirements.

Svendborg offers a wide range of highly engineered products including hydraulic brakes and power units, thruster brakes, soft braking controls and couplings. Svendborg braking solutions are hard at work in key markets including renewable energy, mining, hydropower, cranes and oil & gas, mining, and marine & offshore on applications such as wind and tidal turbines, overland conveyors, propulsion systems, deck equipment, hoists, drawworks, elevators & escalators and dam turbines.



Products

- Hydraulic Brakes
- Hydraulic Power Units
- Soft Braking Controls
- Couplings
- Yaw Systems
- Thruster Brakes
- Rotor Locks
- Brake Disc
- Spares & Accessories

Key Markets

- Wind
- Tidal
- Hydro
- Oil & Gas
- Mining & Aggregate
- Marine
- Crane & Hoist

Contact Us

Jernbanevej 9
5882 Vejstrup
Denmark
Phone: +45 63 255 255
Email: sb@svendborg-brakes.com

www.svendborg-brakes.com



Table of Contents

Specification

DISC BRAKES

BSFI

100 MONOspring	3-4
200 DUALspring - HIGH pressure.....	5-6
200 MONOspring - HIGH pressure	7-8
200 DUALspring - low pressure	9-10
200 MONOspring - low pressure	11-12
300-X-200 ("E") DUALspring.....	13-14
300-MSXX-200 ("E") MONOspring.....	15-16
300-X-300 ("EE") DUALspring.....	17-18
300-MSXX-300 ("EE") MONOspring	19-20
3000 DUALspring.....	21-22
3000 MONOspring	23-24

BSFG

400 DUALspring.....	25-26
---------------------	-------

BSFH

500 DUALspring	27-28
500 MONOspring	29-30

BSFK

500 DUALspring	31-32
500 MONOspring	33-34

NEW BRAKES

BSFH

D500 (DOUBLE PISTON) DUALspring.....	63-64
D500 (DOUBLE PISTON) MONOspring	65-66

SPECIAL RANGE

ELECTRO-HYDRAULIC BRAKE

DRUM Brake 18735	73-74
LIFTING Devices 18830.....	75-76
BRAKE Shoes 18800	77-78

HYDRAULIC WIND RANGE

TURBINES

Direct Drive.....	82-88
Conventional	89-94
Compact	96-106

BSFB

600 DUALspring.....	35-36
600 MONOspring	37-38

BSFA

1000 MONOspring	39-40
-----------------------	-------

BSAB

75 DUAL-ACTION	41-42
90 DUAL-ACTION	43-44
120 DUAL-ACTION	45-46

BSAK

300 DUAL-ACTION	47-48
300 MONO-ACTION.....	49-50
3000 DUAL-ACTION	51-52
3000 MONO-ACTION.....	53-54

BSAL

3000 MONO-ACTION.....	55-56
-----------------------	-------

BSAC

120 DUAL-ACTION	57-58
-----------------------	-------

YSAA

60.....	59-60
---------	-------

BSAH

D500 (DOUBLE PISTON) DUAL-ACTION	67-68
D500 (DOUBLE PISTON) MONO-ACTION.....	69-70

Disc Brake: BSFI 100 MONOspring

Specification

Name: DEB-0100-010-MS-MAR

Date: 24.04.2012

Revision: F



TECHNICAL DATA AND CALCULATION FUNDAMENTALS

CALIPER TYPE	CLAMPING FORCE ¹⁾ [N]		BRAKING FORCE ²⁾ [N]	LOSS OF FORCE PER 1MM [%]	OPERATING PRESSURE ³⁾ MPa	BALANCING PRESSURE ¹⁾ MIN MPa	PAD SURFACE PRESSURE ⁴⁾ [N/mm ²]
	MIN	MAX					
BSFI 105	500	560	400	7.0	14.5	1.50	0.16 - 0.25
BSFI 110	1,000	1,125	800	13.0	14.5	3.00	0.34 - 0.51
BSFI 115	1,500	1,650	1,200	8.0	14.5	4.50	0.49 - 0.75
BSFI 120	2,000	2,250	1,600	12.0	14.5	6.00	0.67 - 1.02
BSFI 125	2,500	2,800	2,000	8.5	14.5	7.49	0.84 - 1.27
BSFI 130	3,000	3,350	2,400	7.0	14.5	8.99	1.00 - 1.52

¹⁾ All figures are based on 1 mm air gap (total)

²⁾ Braking force is based on a min clamping force, nominal coefficient of friction $\mu = 0.4$ and 2 brake surfaces.

³⁾ The operating pressure is the minimum needed for operating the brake

⁴⁾ Pad pressure for organic / sintered pads respectively (based on max. clamping force)

Disc brake: BSFI 100 MONOspring

Specification

BRAKING TORQUE

The braking torque M_B is calculated from following formula where:

a is the number of brakes acting on the disc

F_B is the braking force according to table above [N] or calculated from formula

D_o is the brake disc outer diameter [m]

The actual braking torque may vary depending on adjustment of brake and friction coefficient.

$$M_B = a \cdot F_B \cdot \frac{(D_o - 0,023)}{2} \text{ [Nm]}$$

$$F_B = F_C \cdot 2 \cdot \mu$$

CALCULATION FUNDAMENTALS

MONOSPRING

Weight of caliper without bracket:	Approx. 7 kg
Overall dimensions:	131 x 129 x 147 mm
Pad width (width for heat calculation):	56 mm (organic) 53 mm (sintered)
Pad area: (organic)	3350 mm ² (*)
Max. wear of pad: (organic)	4 mm (*) (=7.0 mm thick)
Pad area: (sintered)	2205 mm ² (*)
Max. wear of pad: (sintered)	4 mm (*) (=7.0 mm thick)
Nominal coefficient of friction:	$\mu = 0.4$
Total piston area - each caliper half:	334 cm ²
Total piston area - each caliper:	334 cm ²
Actuating time (guide value for calculation):	0.4 sec
Pressure connection/port:	1/8" BSP
Recommended pipe size:	6 mm
Maximum operating pressure	23.0 MPa
Operating temperature range - general	from -20°C to +70°C

(For temperatures outside this range contact Svendborg Brakes)

(*) On each brake pad.

Disc Brake: BSFI 200 DUALspring - HIGH pressure

Specification

Name: DEB-0200-004-DS-MAR

Date: 24.01.2012

Revision: C



High pressure (option 400)

TECHNICAL DATA AND CALCULATION FUNDAMENTALS

CALIPER TYPE	CLAMPING FORCE ¹⁾ [N]		BRAKING FORCE ²⁾ [N]	LOSS OF FORCE PER 1MM [%]	OPERATING PRESSURE ³⁾ MPa	BALANCING PRESSURE ¹⁾ MIN MPa	PAD SURFACE PRESSURE ⁴⁾ [N/mm ²]
	MIN	MAX					
BSFI 201 ⁵⁾	1,000	1,300	800	14.0	3.0	1.16	0.16 - 0.24
BSFI 202	2,000	2,340	1,600	10.0	5.0	2.31	0.29 - 0.43
BSFI 203	3,000	3,470	2,400	6.0	6.5	3.47	0.43 - 0.64
BSFI 204	4,000	4,500	3,200	13.0	8.0	4.62	0.56 - 0.83
BSFI 205	5,000	5,640	4,000	9.0	10.0	5.77	0.71 - 1.03
BSFI 206	6,000	6,750	4,800	7.0	11.5	6.93	0.85 - 1.24
BSFI 207	7000	7,720	5,600	5.0	13.0	8.08	0.97 - 1.42
BSFI 208	8,000	8,930	6,400	4.0	14.5	9.23	1.12 - 1.64
BSFI 209	9,000	9,970	7,200	8.0	16.0	10.39	1.25 - 1.83
BSFI 210	10,000	10,840	8,000	7.0	18.0	11.54	1.36 - 1.99
BSFI 211	11,000	11,960	8,800	6.0	19.5	12.69	1.50 - 2.19
BSFI 212	12,000	12,920	9,600	6.0	21.0	13.85	1.62 - 2.37

¹⁾ All figures are based on 1 mm air gap (each side)

²⁾ Braking force is based on a min clamping force, nominal coefficient of friction $\mu = 0.4$ and 2 brake surfaces.

³⁾ The operating pressure is the minimum needed for operating the brake

⁴⁾ Pad pressure for organic / sintered pads respectively (based on max. clamping force)

⁵⁾ Not recommended for general usage - hydraulic balancing pressure is low

Disc Brake: BSFI 200 DUALspring - HIGH pressure

Specification

BRAKING TORQUE

The braking torque M_B is calculated from following formula where:

a is the number of brakes acting on the disc

F_B is the braking force according to table above [N] or calculated from formula

D_o is the brake disc outer diameter [m]

The actual braking torque may vary depending on adjustment of brake and friction coefficient.

$$M_B = a \cdot F_B \cdot \frac{(D_o - 0,07)}{2} \text{ [Nm]}$$

$$F_B = F_C \cdot 2 \cdot \mu$$

CALCULATION FUNDAMENTALS

DUALSPRING

Weight of caliper without bracket:	Approx. 19 kg
Overall dimensions:	195 x 220 x 260 mm
Pad width:	70 mm
Pad area: (organic)	8,000 mm ² (*)
Max. wear of pad: (organic)	7,5 mm (*) "(=8 mm thick)"
Pad area: (sintered)	5,450 mm ² (*)
Max. wear of pad: (sintered)	7,5mm (*) "(=8 mm thick)"
Nominal coefficient of friction:	$\mu = 0.4$
Total piston area - each caliper half:	8.67 cm ²
Total piston area - each caliper:	17.34 cm ²
Volume for each caliper at 1 mm stroke:	1.7 cm ³
Volume for each caliper at 3 mm stroke:	5.2 cm ³
Actuating time (guide value for calculation):	0.3 sec
Pressure connection/port:	1/8" BSP
Drain connection port:	1/8" BSP
Recommended pipe size:	10/8 mm
Maximum operating pressure	23.0 MPa
Operating temperature range - general	from -20°C to +70°C

(For temperatures outside this range contact Svendborg Brakes)

(*) On each brake pad.

Disc Brake: BSFI 200 MONOspring - HIGH pressure

Specification

Name: DEB-0200-004-MS-MAR

Date: 24.01.2012

Revision: C

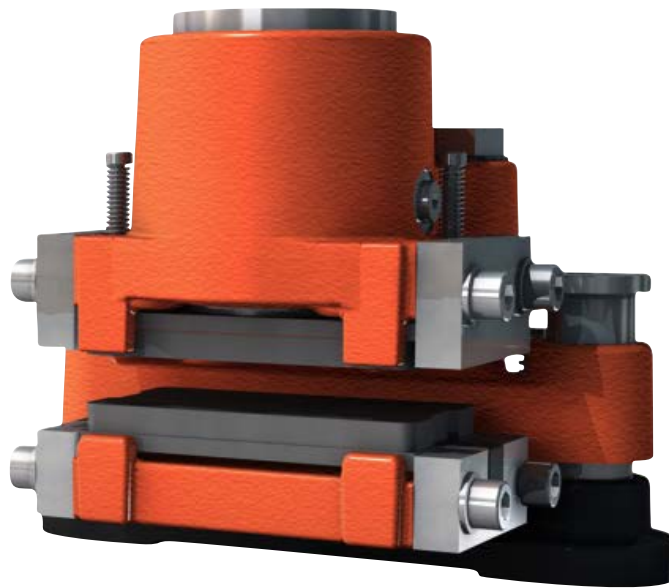

High pressure (option 400)

TECHNICAL DATA AND CALCULATION FUNDAMENTALS

CALIPER TYPE	CLAMPING FORCE ¹⁾ [N]		BRAKING FORCE ²⁾ [N]	LOSS OF FORCE PER 1MM [%]	OPERATING PRESSURE ³⁾ MPa	BALANCING PRESSURE ¹⁾ MIN MPa	PAD SURFACE PRESSURE ⁴⁾ [N/mm ²]
	MIN	MAX					
BSFI 201 ⁵⁾	1,000	1,300	800	14.0	3.0	1.16	0.16 - 0.24
BSFI 202	2,000	2,340	1,600	10.0	5.0	2.31	0.29 - 0.43
BSFI 203	3,000	3,470	2,400	6.0	6.5	3.47	0.43 - 0.64
BSFI 204	4,000	4,500	3,200	13.0	8.0	4.62	0.56 - 0.83
BSFI 205	5,000	5,640	4,000	9.0	10.0	5.77	0.71 - 1.03
BSFI 206	6,000	6,750	4,800	7.0	11.5	6.93	0.85 - 1.24
BSFI 207	7000	7,720	5,600	5.0	13.5	8.08	0.97 - 1.42
BSFI 208	8,000	8,930	6,400	4.0	14.5	9.23	1.12 - 1.64
BSFI 209	9,000	9,970	7,200	8.0	160	10.39	1.25 - 1.83
BSFI 210	10,000	10,840	8,000	7.0	18.0	11.54	1.36 - 1.99
BSFI 211	11,000	11,960	8,800	6.0	19.5	12.69	1.50 - 2.19
BSFI 212	12,000	12,920	9,600	6.0	21.0	13.85	1.62 - 2.37

¹⁾ All figures are based on 1 mm air gap (total)

²⁾ Braking force is based on a min clamping force, nominal coefficient of friction $\mu = 0.4$ and 2 brake surfaces.

³⁾ The operating pressure is the minimum needed for operating the brake

⁴⁾ Pad pressure for organic / sintered pads respectively (based on max. clamping force)

⁵⁾ Not recommended for general usage - hydraulic balancing pressure is low

Disc Brake: BSFI 200 MONOspring - HIGH pressure

Specification

BRAKING TORQUE

The braking torque M_B is calculated from following formula where:

a is the number of brakes acting on the disc

F_B is the braking force according to table above [N] or calculated from formula

D_o is the brake disc outer diameter [m]

The actual braking torque may vary depending on adjustment of brake and friction coefficient.

$$M_B = a \cdot F_B \cdot \frac{(D_o - 0,07)}{2} \text{ [Nm]}$$

$$F_B = F_C \cdot 2 \cdot \mu$$

CALCULATION FUNDAMENTALS

MONOSPRING

Weight of caliper without bracket:	Approx. 19 kg
Overall dimensions:	240 x 180 x 190 mm
Pad width:	70 mm
Pad area: (organic)	8,000 mm ² (*)
Max. wear of pad: (organic)	5 mm (*) "(=10,5 mm thick)"
Pad area: (sintered)	5,450 mm ² (*)
Max. wear of pad: (sintered)	5 mm (*) "(=10,5 mm thick)"
Nominal coefficient of friction:	$\mu = 0.4$
Total piston area - each caliper half:	8.67 cm ²
Total piston area - each caliper:	8.67 cm ²
Volume for each caliper at 1 mm stroke:	0.87 cm ³
Volume for each caliper at 3 mm stroke:	1.73 cm ³
Actuating time (guide value for calculation):	0.3 sec
Pressure connection/port:	1/8" BSP
Drain connection port:	1/8" BSP
Recommended pipe size:	10/8 mm
Maximum operating pressure	23.0 MPa
Operating temperature range - general	from -20°C to +70°C

(For temperatures outside this range contact Svendborg Brakes)

(*) On each brake pad.

Disc Brake: BSFI 200 DUALspring - low pressure

Specification

Name: DEB-0200-004-DS-MAR

Date: 24.01.2012

Revision: C



Low pressure (option 300)

TECHNICAL DATA AND CALCULATION FUNDAMENTALS

CALIPER TYPE	CLAMPING FORCE ¹⁾ [N]		BRAKING FORCE ²⁾ [N]	LOSS OF FORCE PER 1MM [%]	OPERATING PRESSURE ³⁾ MPa	BALANCING PRESSURE ¹⁾ MIN MPa	PAD SURFACE PRESSURE ⁴⁾ [N/mm ²]
	MIN	MAX					
BSFI 202	2,000	2,340	1,600	10.0	4.0	1.82	0.29 - 0.43
BSFI 203	3,000	3,470	2,400	6.0	5.5	2.73	0.43 - 0.64
BSFI 204	4,000	4,500	3,200	13.0	6.5	3.64	0.56 - 0.83
BSFI 205	5,000	5,640	4,000	9.0	8.0	4.55	0.71 - 1.03
BSFI 206	6,000	6,750	4,800	7.0	9.0	5.46	0.85 - 1.24
BSFI 207	7000	7,720	5,600	5.0	10.5	6.37	0.97 - 1.42
BSFI 208	8,000	8,930	6,400	4.0	11.5	7.28	1.12 - 1.64
BSFI 209	9,000	9,970	7,200	8.0	13.0	8.19	1.25 - 1.83
BSFI 210	10,000	10,840	8,000	7.0	14.0	9.10	1.36 - 1.99
BSFI 211	11,000	11,960	8,800	6.0	15.5	10.01	1.50 - 2.19
BSFI 212	12,000	12,920	9,600	6.0	17.0	10.92	1.62 - 2.37
BSFI 213	13,000	14,000	10,400	11.0	18.0	11.83	1.75 - 2.57

¹⁾ All figures are based on 1 mm air gap (each side)

²⁾ Braking force is based on a min clamping force, nominal coefficient of friction $\mu = 0.4$ and 2 brake surfaces.

³⁾ The operating pressure is the minimum needed for operating the brake

⁴⁾ Pad pressure for organic / sintered pads respectively (based on max. clamping force)

Disc Brake: BSFI 200 DUALspring - low pressure

Specification

BRAKING TORQUE

The braking torque M_B is calculated from following formula where:

a is the number of brakes acting on the disc

F_B is the braking force according to table above [N] or calculated from formula

D_o is the brake disc outer diameter [m]

The actual braking torque may vary depending on adjustment of brake and friction coefficient.

$$M_B = a \cdot F_B \cdot \frac{(D_o - 0,07)}{2} \text{ [Nm]}$$

$$F_B = F_C \cdot 2 \cdot \mu$$

CALCULATION FUNDAMENTALS

DUALSPRING

Weight of caliper without bracket:	Approx. 19 kg
Overall dimensions:	195 x 220 x 260 mm
Pad width:	70 mm
Pad area: (organic)	8,000 mm ² (*)
Max. wear of pad: (organic)	7,5 mm (*) "(=8 mm thick)"
Pad area: (sintered)	5,450 mm ² (*)
Max. wear of pad: (sintered)	7,5mm (*) "(=8 mm thick)"
Nominal coefficient of friction:	$\mu = 0.4$
Total piston area - each caliper half:	11.0 cm ²
Total piston area - each caliper:	22.0 cm ²
Volume for each caliper at 1 mm stroke:	2.2 cm ³
Volume for each caliper at 3 mm stroke:	6.6 cm ³
Actuating time (guide value for calculation):	0.3 sec
Pressure connection/port:	1/8" BSP
Drain connection port:	1/8" BSP
Recommended pipe size:	10/8 mm
Maximum operating pressure	23.0 MPa
Operating temperature range - general	from -20°C to +70°C

(For temperatures outside this range contact Svendborg Brakes)

(*) On each brake pad.

Disc Brake: BSFI 200 MONOspring - low pressure

Specification

Name: DEB-0200-004-MS-MAR

Date: 24.01.2012

Revision: C

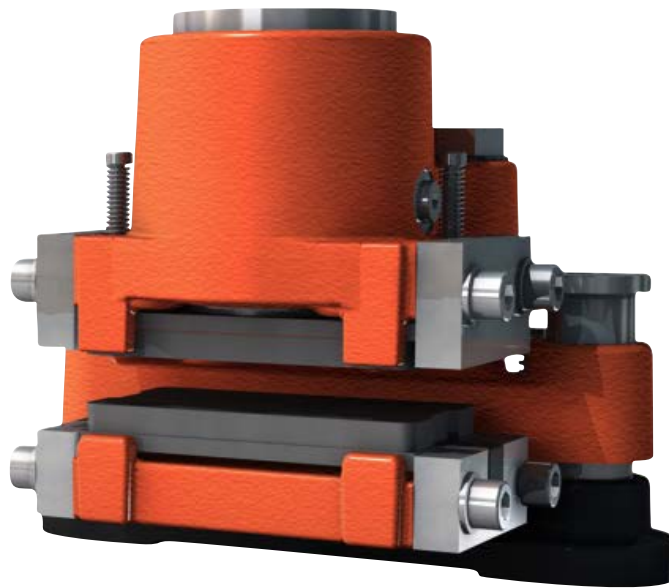

Low pressure (option 300)

TECHNICAL DATA AND CALCULATION FUNDAMENTALS

CALIPER TYPE	CLAMPING FORCE ¹⁾ [N]		BRAKING FORCE ²⁾ [N]	LOSS OF FORCE PER 1MM [%]	OPERATING PRESSURE ³⁾ MPa	BALANCING PRESSURE ¹⁾ MIN MPa	PAD SURFACE PRESSURE ⁴⁾ [N/mm ²]
	MIN	MAX					
BSFI 202	2,000	2,340	1,600	10.0	4.0	1.82	0.29 - 0.43
BSFI 203	3,000	3,470	2,400	6.0	5.5	2.73	0.43 - 0.64
BSFI 204	4,000	4,500	3,200	13.0	6.5	3.64	0.56 - 0.83
BSFI 205	5,000	5,640	4,000	9.0	8.0	4.55	0.71 - 1.03
BSFI 206	6,000	6,750	4,800	7.0	9.0	5.46	0.85 - 1.24
BSFI 207	7000	7,720	5,600	5.0	10.5	6.37	0.97 - 1.42
BSFI 208	8,000	8,930	6,400	4.0	11.5	7.28	1.12 - 1.64
BSFI 209	9,000	9,970	7,200	8.0	13.0	8.19	1.25 - 1.83
BSFI 210	10,000	10,840	8,000	7.0	14.0	9.10	1.36 - 1.99
BSFI 211	11,000	11,960	8,800	6.0	15.5	10.01	1.50 - 2.19
BSFI 212	12,000	12,920	9,600	6.0	17.0	10.92	1.62 - 2.37
BSFI 213	13,000	14,000	10,400	11.0	18.0	11.83	1.75 - 2.57

¹⁾ All figures are based on 1 mm air gap (total)

²⁾ Braking force is based on a min clamping force, nominal coefficient of friction $\mu = 0.4$ and 2 brake surfaces.

³⁾ The operating pressure is the minimum needed for operating the brake

⁴⁾ Pad pressure for organic / sintered pads respectively (based on max. clamping force)

Disc Brake: BSFI 200 MONOspring - low pressure

Specification

BRAKING TORQUE

The braking torque M_B is calculated from following formula where:

a is the number of brakes acting on the disc

F_B is the braking force according to table above [N] or calculated from formula

D_o is the brake disc outer diameter [m]

The actual braking torque may vary depending on adjustment of brake and friction coefficient.

$$M_B = a \cdot F_B \cdot \frac{(D_o - 0,07)}{2} \text{ [Nm]}$$

$$F_B = F_C \cdot 2 \cdot \mu$$

CALCULATION FUNDAMENTALS

MONOSPRING

Weight of caliper without bracket:	Approx. 17 kg
Overall dimensions:	240 x 180 x 190 mm
Pad width:	70 mm
Pad area: (organic)	8,000 mm ² (*)
Max. wear of pad: (organic)	5 mm (*) "(=10,5 mm thick)"
Pad area: (sintered)	5,450 mm ² (*)
Max. wear of pad: (sintered)	5 mm (*) "(=10,5 mm thick)"
Nominal coefficient of friction:	$\mu = 0.4$
Total piston area - each caliper half:	11.0 cm ²
Total piston area - each caliper:	11.0 cm ²
Volume for each caliper at 1 mm stroke:	1.1 cm ³
Volume for each caliper at 3 mm stroke:	3.3 cm ³
Actuating time (guide value for calculation):	0.3 sec
Pressure connection/port:	1/8" BSP
Drain connection port:	1/8" BSP
Recommended pipe size:	10/8 mm
Maximum operating pressure	23.0 MPa
Operating temperature range - general	from -20°C to +70°C

(For temperatures outside this range contact Svendborg Brakes)

(*) On each brake pad.

Disc Brake: BSFI 300-X-200 ("E") DUALspring

Specification

Name: DEB-0300-016-DS-MAR

Date: 15.07.2011R

Revision: F

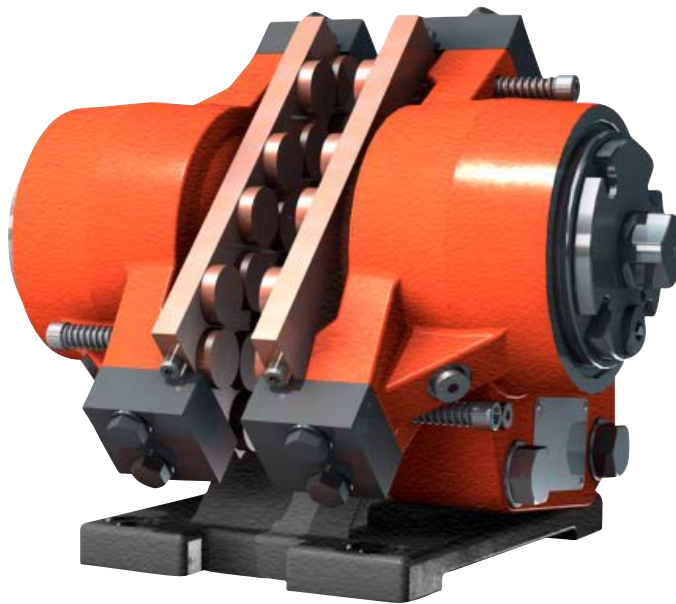

TECHNICAL DATA AND CALCULATION FUNDAMENTALS

CALIPER TYPE	CLAMPING FORCE ¹⁾ [N]		BRAKING FORCE ²⁾ [N]	LOSS OF FORCE PER 1MM [%]	OPERATING PRESSURE ³⁾ MPa	BALANCING PRESSURE ¹⁾ MIN MPa	PAD SURFACE PRESSURE ⁴⁾ [N/mm ²]
	MIN	MAX					
BSFI 317	17,000	19,000	13,600	4.0	4.2	2.46	0.66 - 0.95
BSFI 318	18,000	19,500	14,400	4.0	4.2	2.61	0.67 - 0.98
BSFI 320	20,000	22,200	16,000	3.0	4.5	2.90	0.77 - 1.11
BSFI 322	22,000	24,500	17,600	3.0	5.0	3.19	0.84 - 1.23
BSFI 325	25,000	27,800	20,000	12.0	5.5	3.62	0.96 - 1.39
BSFI 330	30,000	33,100	24,000	10.0	7.0	4.35	1.14 - 1.66
BSFI 332	32,000	35,200	25,600	9.0	7.0	4.63	1.21 - 1.76
BSFI 335	35,000	38,300	28,000	8.0	7.5	5.07	1.32 - 1.92
BSFI 340	40,000	43,600	32,000	7.0	8.5	5.79	1.50 - 2.18
BSFI 345	45,000	48,800	36,000	6.0	9.5	6.52	1.68 - 2.44
BSFI 350	50,000	55,000	40,000	11.0	10.5	7.24	1.86 - 3.70
BSFI 355	55,000	59,300	44,000	10.0	12.0	7.69	2.04 - 2.97
BSFI 360	60,000	65,000	48,000	9.0	13.0	8.69	2.22 - 3.22

¹⁾ All figures are based on 1 mm air gap. (Each side)

²⁾ Braking force is based on a min clamping force, nominal coefficient of friction $\mu = 0.4$ and 2 brake surfaces.

³⁾ The operating pressure is the minimum needed for operating the brake

⁴⁾ Pad pressure for organic / sintered pads respectively (based on max. clamping force)

Disc Brake: BSFI 300-X-200 ("E") DUALspring

Specification

BRAKING TORQUE

The braking torque M_B is calculated from following formula where:

a is the number of brakes acting on the disc

F_B is the braking force according to table above [N] or calculated from formula

D_o is the brake disc outer diameter [m]

The actual braking torque may vary depending on adjustment of brake and friction coefficient.

$$M_B = a \cdot F_B \cdot \frac{(D_o - 0,13)}{2} \text{ [Nm]}$$

$$F_B = F_C \cdot 2 \cdot \mu$$

CALCULATION FUNDAMENTALS

DUALSPRING

Weight of caliper without bracket:	Approx. 65 kg
Overall dimensions:	326 x 316 x 379 mm
Pad width:	130 mm
Pad area: (organic)	29,000 mm ² (*)
Max. wear of pad: (organic)	10 mm (*) "(=14 mm thick)"
Pad area: (sintered)	20,000 mm ² (*)
Max. wear of pad: (sintered)	7 mm (*) "(=17 mm thick)"
Nominal coefficient of friction:	$\mu = 0.4$
Total piston area - each caliper half:	69.1 cm ²
Total piston area - each caliper:	138.2 cm ²
Volume for each caliper at 1 mm stroke:	13.8 cm ³
Volume for each caliper at 3 mm stroke:	41,4 cm ³
Actuating time (guide value for calculation):	0.3 sec
Pressure connection/port:	1/4" BSP
Drain connection port:	1/8" BSP
Recommended pipe size:	10/8 mm
Maximum operating pressure	23.0 MPa
Operating temperature range - general	from -20°C to +70°C

(For temperatures outside this range contact Svendborg Brakes)

(*) On each brake pad.

Disc Brake: BSFI 300-MSXX-200 ("E") MONOspring

Specification

Name: DEB-0300-016-MS-MAR

Date: 15.07.2011

Revision: F

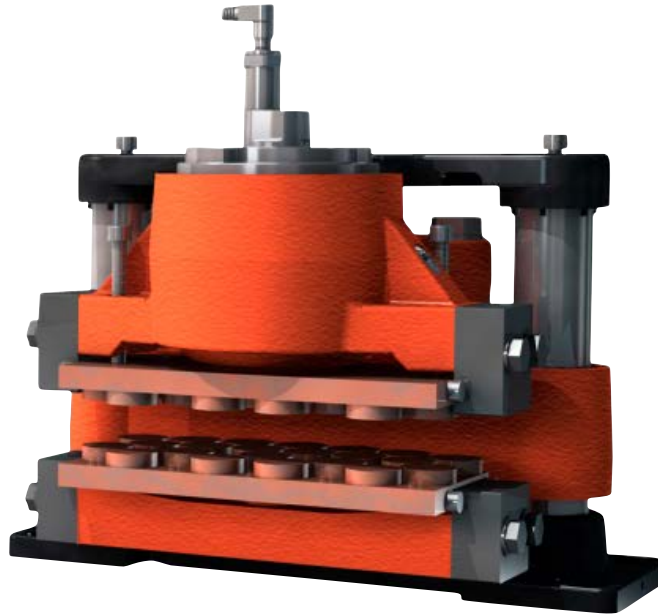

TECHNICAL DATA AND CALCULATION FUNDAMENTALS

CALIPER TYPE	CLAMPING FORCE ¹⁾ [N]		BRAKING FORCE ²⁾ [N]	LOSS OF FORCE PER 1MM [%]	OPERATING PRESSURE ³⁾ MPa	BALANCING PRESSURE ¹⁾ MIN MPa	PAD SURFACE PRESSURE ⁴⁾ [N/mm ²]
	MIN	MAX					
BSFI 317	17,000	19,000	13,600	4.0	4.2	2.46	0.66 - 0.95
BSFI 318	18,000	19,500	14,400	4.0	4.2	2.61	0.67 - 0.98
BSFI 320	20,000	22,200	16,000	3.0	4.5	2.90	0.77 - 1.11
BSFI 322	22,000	24,500	17,600	3.0	5.0	3.19	0.84 - 1.23
BSFI 325	25,000	27,800	20,000	12.0	5.5	3.62	0.96 - 1.39
BSFI 330	30,000	33,100	24,000	10.0	7.0	4.35	1.14 - 1.66
BSFI 332	32,000	35,200	25,600	9.0	7.0	4.63	1.21 - 1.76
BSFI 335	35,000	38,300	28,000	8.0	7.5	5.07	1.32 - 1.92
BSFI 340	40,000	43,600	32,000	7.0	8.5	5.79	1.50 - 2.18
BSFI 345	45,000	48,800	36,000	6.0	9.5	6.52	1.68 - 2.44
BSFI 350	50,000	55,000	40,000	11.0	10.5	7.24	1.86 - 3.70
BSFI 355	55,000	59,300	44,000	10.0	12.0	7.69	2.04 - 2.97
BSFI 360	60,000	65,000	48,000	9.0	13.0	8.69	2.22 - 3.22

¹⁾ All figures are based on 1 mm air gap. (Total)

²⁾ Braking force is based on a min clamping force, nominal coefficient of friction $\mu = 0.4$ and 2 brake surfaces.

³⁾ The operating pressure is the minimum needed for operating the brake

⁴⁾ Pad pressure for organic / sintered pads respectively (based on max. clamping force)

Disc Brake: BSFI 300-MSXX-200 ("E") MONOspring

Specification

BRAKING TORQUE

The braking torque M_B is calculated from following formula where:

a is the number of brakes acting on the disc

F_B is the braking force according to table above [N] or calculated from formula

D_o is the brake disc outer diameter [m]

The actual braking torque may vary depending on adjustment of brake and friction coefficient.

$$M_B = a \cdot F_B \cdot \frac{(D_o - 0,13)}{2} \text{ [Nm]}$$

$$F_B = F_C \cdot 2 \cdot \mu$$

CALCULATION FUNDAMENTALS

MONOSPRING

Weight of caliper without bracket:	Approx. 85 kg
Overall dimensions:	279 x 420 x 299 mm
Pad width:	130 mm
Pad area: (organic)	29,000 mm ² (*)
Max. wear of pad: (organic)	5 mm (*) "(=19 mm thick)"
Pad area: (sintered)	20,000 mm ² (*)
Max. wear of pad: (sintered)	5 mm (*) "(=19 mm thick)"
Nominal coefficient of friction:	$\mu = 0.4$
Total piston area - each caliper half:	69.1 cm ²
Total piston area - each caliper:	69.1 cm ²
Volume for each caliper at 1 mm stroke:	6,9 cm ³
Volume for each caliper at 3 mm stroke:	20,7 cm ³
Actuating time (guide value for calculation):	0.3 sec
Pressure connection/port:	1/4" BSP
Drain connection port:	1/8" BSP
Recommended pipe size:	10/8 mm
Maximum operating pressure	23.0 MPa
Operating temperature range - general	from -20°C to +70°C

(For temperatures outside this range contact Svendborg Brakes)

(*) On each brake pad.

Disc Brake: BSFI 300-X-300 ("EE") DUALspring

Specification

Name: DEB-0300-DS-MAR

Date: 21.03.2013

Revision: D

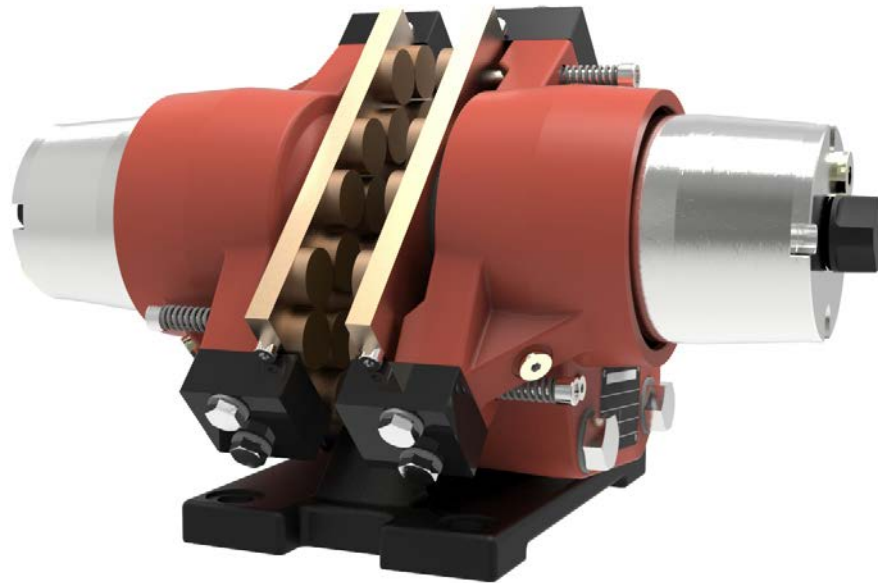

TECHNICAL DATA AND CALCULATION FUNDAMENTALS

CALIPER TYPE	CLAMPING FORCE ¹⁾ [N]		BRAKING FORCE ²⁾ [N]	LOSS OF FORCE PER 1MM [%]	OPERATING PRESSURE ³⁾ MPa	BALANCING PRESSURE ¹⁾ MIN MPa	PAD SURFACE PRESSURE ⁴⁾ [N/mm ²]
	MIN	MAX					
BSFI 317	17,000	19,000	13,600	3.0	4.0	2.46	0.66 - 0.95
BSFI 318	18,000	19,500	14,400	4.0	4.3	2.61	0.67 - 0.98
BSFI 320	20,000	22,200	16,000	9.0	4.5	2.90	0.77 - 1.11
BSFI 323	23,000	25,800	18,400	8.5	5.0	3.33	0.89 - 1.29
BSFI 325	25,000	27,800	20,000	7.0	5.5	3.62	0.96 - 1.39
BSFI 330	30,000	33,100	24,000	6.0	7.0	4.35	1.14 - 1.66
BSFI 332	32,000	35,200	25,600	5.0	7.0	4.63	1.21 - 1.76
BSFI 335	35,000	38,300	28,000	5.0	7.5	5.07	1.32 - 1.92
BSFI 340	40,000	43,600	32,000	4.0	8.5	5.79	1.50 - 2.18
BSFI 345	45,000	48,800	36,000	3.0	9.5	6.52	1.68 - 2.44
BSFI 350	50,000	55,000	40,000	7.0	10.5	7.24	1.86 - 3.70
BSFI 355	55,000	59,300	44,000	6.0	12.0	7.69	2.04 - 2.97
BSFI 360	60,000	65,000	48,000	6.0	13.0	8.69	2.22 - 3.22

¹⁾ All figures are based on 1 mm air gap. (Each side)

²⁾ Braking force is based on a min clamping force, nominal coefficient of friction $\mu = 0.4$ and 2 brake surfaces.

³⁾ The operating pressure is the minimum needed for operating the brake

⁴⁾ Pad pressure for organic / sintered pads respectively (based on max. clamping force)

Disc Brake: BSFI 300-X-300 ("EE") DUALspring

Specification

BRAKING TORQUE

The braking torque M_B is calculated from following formula where:

a is the number of brakes acting on the disc

F_B is the braking force according to table above [N] or calculated from formula

D_o is the brake disc outer diameter [m]

The actual braking torque may vary depending on adjustment of brake and friction coefficient.

$$M_B = a \cdot F_B \cdot \frac{(D_o - 0,13)}{2} \text{ [Nm]}$$

$$F_B = F_C \cdot 2 \cdot \mu$$

CALCULATION FUNDAMENTALS

DUALSPRING

Weight of caliper without bracket:	Approx. 80 kg
Overall dimensions:	326 x 316 x 540 mm
Pad width:	130 mm
Pad area: (organic)	29,000 mm ² (*)
Max. wear of pad: (organic)	10 mm (*) "(=14 mm thick)"
Pad area: (sintered)	20,000 mm ² (*)
Max. wear of pad: (sintered)	7 mm (*) "(=17 mm thick)"
Nominal coefficient of friction:	$\mu = 0.4$
Total piston area - each caliper half:	69.1 cm ²
Total piston area - each caliper:	138.2 cm ²
Volume for each caliper at 1 mm stroke:	13.8 cm ³
Volume for each caliper at 3 mm stroke:	41,4 cm ³
Actuating time (guide value for calculation):	0.3 sec
Pressure connection/port:	1/4" BSP
Drain connection port:	1/8" BSP
Recommended pipe size:	10/8 mm
Maximum operating pressure	23.0 MPa
Operating temperature range - general	from -20°C to +70°C

(For temperatures outside this range contact Svendborg Brakes)

(*) On each brake pad.

Disc Brake: BSFI 300-MSXX-300 ("EE") MONOspring

Specification

Name: DEB-0300-MS-MAR

Date: 21.03.2013

Revision: D

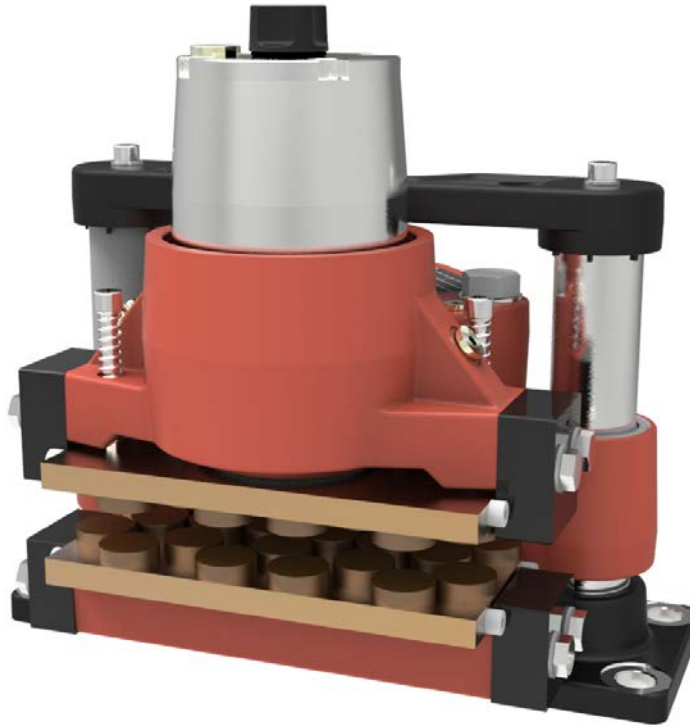

TECHNICAL DATA AND CALCULATION FUNDAMENTALS

CALIPER TYPE	CLAMPING FORCE ¹⁾ [N]		BRAKING FORCE ²⁾ [N]	LOSS OF FORCE PER 1MM [%]	OPERATING PRESSURE ³⁾ MPa	BALANCING PRESSURE ¹⁾ MIN MPa	PAD SURFACE PRESSURE ⁴⁾ [N/mm ²]
	MIN	MAX					
BSFI 317	17,000	19,000	13,600	3.0	4.0	2.46	0.66 - 0.95
BSFI 318	18,000	19,500	14,400	4.0	4.3	2.61	0.67 - 0.98
BSFI 320	20,000	22,200	16,000	9.0	4.5	2.90	0.77 - 1.11
BSFI 323	23,000	25,800	18,400	8.5	5.0	3.33	0.89 - 1.29
BSFI 325	25,000	27,800	20,000	7.0	5.5	3.62	0.96 - 1.39
BSFI 330	30,000	33,100	24,000	6.0	7.0	4.35	1.14 - 1.66
BSFI 332	32,000	35,200	25,600	5.0	7.0	4.63	1.21 - 1.76
BSFI 335	35,000	38,300	28,000	5.0	7.5	5.07	1.32 - 1.92
BSFI 340	40,000	43,600	32,000	4.0	8.5	5.79	1.50 - 2.18
BSFI 345	45,000	48,800	36,000	6.0	9.5	6.52	1.68 - 2.44
BSFI 350	50,000	55,000	40,000	7.0	10.5	7.24	1.86 - 3.70
BSFI 355	55,000	59,300	44,000	10.0	12.0	7.96	2.04 - 2.97
BSFI 360	60,000	65,000	48,000	6.0	13.0	8.69	2.22 - 3.22

¹⁾ All figures are based on 1 mm air gap. (Total)

²⁾ Braking force is based on a min clamping force, nominal coefficient of friction $\mu = 0.4$ and 2 brake surfaces.

³⁾ The operating pressure is the minimum needed for operating the brake

⁴⁾ Pad pressure for organic / sintered pads respectively (based on max. clamping force)

Disc Brake: BSFI 300-MSXX-300 ("EE") MONOspring

Specification

BRAKING TORQUE

The braking torque M_B is calculated from following formula where:

a is the number of brakes acting on the disc

F_B is the braking force according to table above [N] or calculated from formula

D_o is the brake disc outer diameter [m]

The actual braking torque may vary depending on adjustment of brake and friction coefficient.

$$M_B = a \cdot F_B \cdot \frac{(D_o - 0,13)}{2} \text{ [Nm]}$$

$$F_B = F_C \cdot 2 \cdot \mu$$

CALCULATION FUNDAMENTALS

MONOSPRING

Weight of caliper withoutout bracket:	Approx. 85 kg
Overall dimensions:	326 x 316 x 540 mm
Pad width:	130 mm
Pad area: (organic)	29,000 mm ² (*)
Max. wear of pad: (organic)	5 mm (*) "(=19 mm thick)"
Pad area: (sintered)	20,000 mm ² (*)
Max. wear of pad: (sintered)	5 mm (*) "(=19 mm thick)"
Nominal coefficient of friction:	$\mu = 0.4$
Total piston area - each caliper half:	69.1 cm ²
Total piston area - each caliper:	69.1 cm ²
Volume for each caliper at 1 mm stroke:	6,9 cm ³
Volume for each caliper at 3 mm stroke:	20,7 cm ³
Actuating time (guide value for calculation):	0.3 sec
Pressure connection/port:	1/4" BSP
Drain connection port:	1/8" BSP
Recommended pipe size:	10/8 mm
Maximum operating pressue	23.0 MPa
Operating temperature range - general	from -20°C to +70°C

(For temperatures outside this range contact Svendborg Brakes)

(*) On each brake pad.

Disc Brake: BSFI 3000 DUALspring

Specification

Name: DEB-3000-001-DS-MAR

Date: 23.01.2012

Revision: B



TECHNICAL DATA AND CALCULATION FUNDAMENTALS

CALIPER TYPE	CLAMPING FORCE ¹⁾ [N]		BRAKING FORCE ²⁾ [N]	LOSS OF FORCE PER 1MM [%]	OPERATING PRESSURE ³⁾ MPa	BALANCING PRESSURE ¹⁾ MIN MPa	PAD SURFACE PRESSURE ⁴⁾ [N/mm ²]
	MIN	MAX					
BSFI 3020	20,000	23,000	16,000	5.0	4.0	2.28	0.39 - 0.64
BSFI 3025	24,800	24,800	19,840	4.0	4.5	2.82	0.46 - 0.76
BSFI 3030	30,000	33,500	24,000	5.0	5.0	3.42	0.56 - 0.93
BSFI 3040	40,000	44,000	32,000	4.0	6.5	4.55	0.74 - 1.22
BSFI 3046	46,000	50,000	36,800	4.0	7.5	5.23	0.84 - 1.39
BSFI 3050	50,000	55,000	40,000	6.0	8.0	5.69	0.92 - 1.53
BSFI 3056	56,000	60,000	44,800	6.0	9.0	6.37	1.01 - 1.67
BSFI 3060	60,000	66,000	48,000	5.0	9.5	6.83	1.11 - 1.83
BSFI 3070	70,000	77,000	56,000	4.0	11.5	7.96	1.29 - 2.14
BSFI 3080	80,000	88,000	64,000	7.0	13.0	9.10	1.48 - 2.44
BSFI 3085	85,000	93,000	68,000	7.0	14.0	9.67	1.56 - 2.58
BSFI 3090	90,000	98,500	72,000	13.0	14.5	10.24	1.65 - 2.74
BSFI 3100	100,000	109,000	80,000	11.0	16.0	11.37	1.83 - 3.03
BSFI 3110	110,000	119,000	88,000	10.0	17.5	12.51	2.00 - 3.31
BSFI 3120	120,000	130,000	96,000	9.0	19.0	13.65	2.18 - 3.61

¹⁾ All figures are based on 1 mm air gap. (Each side)

²⁾ Braking force is based on a min clamping force, nominal coefficient of friction $\mu = 0.4$ and 2 brake surfaces.

³⁾ The operating pressure is the minimum needed for operating the brake

⁴⁾ Pad pressure for organic / sintered pads respectively (based on max. clamping force)

Disc Brake: BSFI 3000 DUALspring

Specification

BRAKING TORQUE

The braking torque M_B is calculated from following formula where:

a is the number of brakes acting on the disc

F_B is the braking force according to table above [N] or calculated from formula

D_o is the brake disc outer diameter [m]

The actual braking torque may vary depending on adjustment of brake and friction coefficient.

$$M_B = a \cdot F_B \cdot \frac{(D_o - 0,20)}{2} \text{ [Nm]}$$

$$F_B = F_C \cdot 2 \cdot \mu$$

CALCULATION FUNDAMENTALS

DUALSPRING

Weight of caliper without bracket:	Approx. 170 kg
Pad width:	200 mm
Pad area: (organic)	59,600 mm ² (*)
Max. wear of pad: (organic)	10 mm (*) "(=22 mm thick)"
Pad area: (sintered)	36,000 mm ² (*)
Max. wear of pad: (sintered)	10 mm (*) "(=22 mm thick)"
Nominal coefficient of friction:	$\mu = 0.4$
Total piston area - each caliper half:	88 cm ²
Total piston area - each caliper:	176 cm ²
Volume for each caliper at 1 mm stroke:	17.6 cm ³
Volume for each caliper at 3 mm stroke:	52.8 cm ³
Actuating time (guide value for calculation):	0.3 sec
Pressure connection/port:	1/4" BSP
Drain connection port:	1/8" BSP
Recommended pipe size:	10/8 mm
Maximum operating pressure	23.0 MPa
Operating temperature range - general	from -20°C to +70°C

(For temperatures outside this range contact Svendborg Brakes)

(*) On each brake pad.

Disc Brake: BSFI 3000 MONOspring

Specification

Name: DEB-3000-001-MS-MAR

Date: 23.01.2012

Revision: B

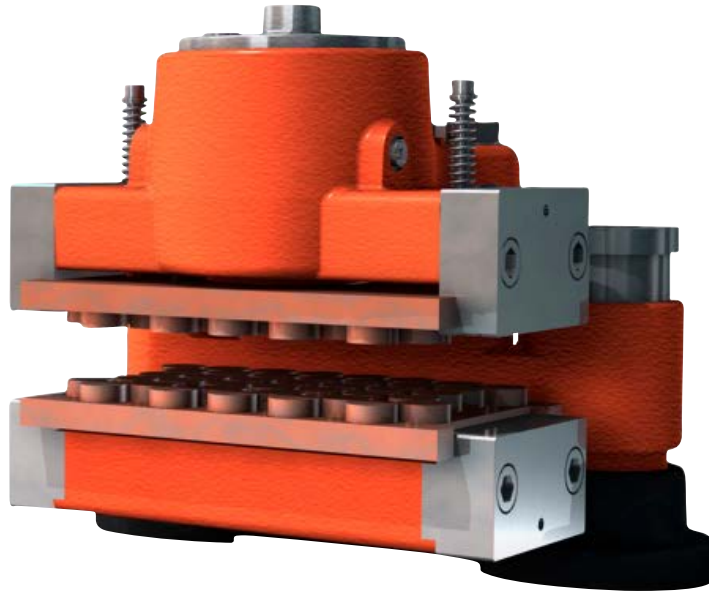

TECHNICAL DATA AND CALCULATION FUNDAMENTALS

CALIPER TYPE	CLAMPING FORCE ¹⁾ [N]		BRAKING FORCE ²⁾ [N]	LOSS OF FORCE PER 1MM [%]	OPERATING PRESSURE ³⁾ MPa	BALANCING PRESSURE ¹⁾ MIN MPa	PAD SURFACE PRESSURE ⁴⁾ [N/mm ²]
	MIN	MAX					
BSFI 3020	20,000	23,000	16,000	5.0	4.0	2.28	0.39 - 0.64
BSFI 3025	24,800	24,800	19,840	4.0	4.5	2.82	0.46 - 0.76
BSFI 3030	30,000	33,500	24,000	5.0	5.0	3.42	0.56 - 0.93
BSFI 3040	40,000	44,000	32,000	4.0	6.5	4.55	0.74 - 1.22
BSFI 3046	46,000	50,000	36,800	4.0	7.5	5.23	0.84 - 1.39
BSFI 3050	50,000	55,000	40,000	6.0	8.0	5.69	0.92 - 1.53
BSFI 3056	56,000	60,000	44,800	6.0	9.0	6.37	1.01 - 1.67
BSFI 3060	60,000	66,000	48,000	5.0	9.5	6.83	1.11 - 1.83
BSFI 3070	70,000	77,000	56,000	4.0	11.5	7.96	1.29 - 2.14
BSFI 3080	80,000	88,000	64,000	7.0	13.0	9.10	1.48 - 2.44
BSFI 3085	85,000	93,000	68,000	7.0	14.0	9.67	1.56 - 2.58
BSFI 3090	90,000	98,500	72,000	13.0	14.5	10.24	1.65 - 2.74
BSFI 3100	100,000	109,000	80,000	11.0	16.0	11.37	1.83 - 3.03
BSFI 3110	110,000	119,000	88,000	10.0	17.5	12.51	2.00 - 3.31
BSFI 3120	120,000	130,000	96,000	9.0	19.0	13.65	2.18 - 3.61

¹⁾ All figures are based on 1 mm air gap. (Total)

²⁾ Braking force is based on a min clamping force, nominal coefficient of friction $\mu = 0.4$ and 2 brake surfaces.

³⁾ The operating pressure is the minimum needed for operating the brake

⁴⁾ Pad pressure for organic / sintered pads respectively (based on max. clamping force)

Disc Brake: BSFI 3000 MONOspring

Specification

BRAKING TORQUE

The braking torque M_B is calculated from following formula where:

a is the number of brakes acting on the disc

F_B is the braking force according to table above [N] or calculated from formula

D_o is the brake disc outer diameter [m]

The actual braking torque may vary depending on adjustment of brake and friction coefficient.

$$M_B = a \cdot F_B \cdot \frac{(D_o - 0,20)}{2} \text{ [Nm]}$$

$$F_B = F_C \cdot 2 \cdot \mu$$

CALCULATION FUNDAMENTALS

MONOSPRING

Weight of caliper without bracket:	175 kg
Pad width:	200 mm
Pad area: (organic)	59,600 mm ² (*)
Max. wear of pad: (organic)	5 mm (*) "(=27 mm thick)"
Pad area: (sintered)	36,000 mm ² (*)
Max. wear of pad: (sintered)	5 mm (*) "(=27 mm thick)"
Nominal coefficient of friction:	$\mu = 0.4$
Total piston area - each caliper half:	88 cm ²
Total piston area - each caliper:	88 cm ²
Volume for each caliper at 1 mm stroke:	8.8 cm ³
Volume for each caliper at 3 mm stroke:	26.4 cm ³
Actuating time (guide value for calculation):	0.3 sec
Pressure connection/port:	1/4" BSP
Drain connection port:	1/8" BSP
Recommended pipe size:	10/8 mm
Maximum operating pressure	23.0 MPa
Operating temperature range - general	from -20°C to +70°C

(For temperatures outside this range contact Svendborg Brakes)

(*) On each brake pad.

Disc Brake: BSFG 400 DUALspring

Specification

Name: DEB-0400-001-DS-MAR
Date: 24.04.2007
Revision: A

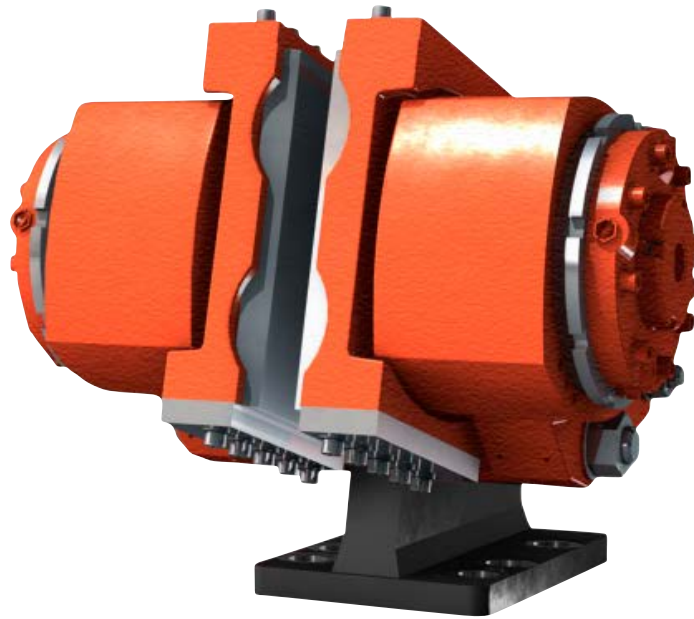

TECHNICAL DATA AND CALCULATION FUNDAMENTALS

CALIPER TYPE	CLAMPING FORCE ¹⁾ [N]		BRAKING FORCE ³⁾ [N]	LOSS OF FORCE PER 1MM [%]	OPERATING PRESSURE ³⁾ MPa	PAD SURFACE PRESSURE ¹⁾ MPa	PAD SURFACE PRESSURE ⁴⁾ [N/mm ²]
	MIN	MAX					
BSFG 403	34,300	38,400	27,500	7.0	7.0	4.60	0.61
BSFG 405	55,900	62,600	45,000	6.0	10.5	7.50	0.99
BSFG 408	80,100	89,700	64,000	6.0	14.5	10.74	1.42
BSFG 412 ⁵⁾	120,000	134,000	96,000	9.0	22.0	16.09	2.13

¹⁾ All figures are based on 1 mm air gap. (Each side)

²⁾ Braking force is based on a min clamping force, nominal coefficient of friction $\mu = 0.4$ and 2 brake surfaces.

³⁾ The operating pressure is the minimum needed for operating the brake

⁴⁾ Pad pressure for organic pads (based on max. clamping force)

⁵⁾ Not recommended for general usage - special high pressure version

Disc Brake: BSFG 400 DUALspring

Specification

BRAKING TORQUE

The braking torque M_B is calculated from following formula where:

a is the number of brakes acting on the disc

F_B is the braking force according to table above [N] or calculated from formula

D_o is the brake disc outer diameter [m]

The actual braking torque may vary depending on adjustment of brake and friction coefficient.

$$M_B = a \cdot F_B \cdot \frac{(D_o - 0,22)}{2} \text{ [Nm]}$$

$$F_B = F_C \cdot 2 \cdot \mu$$

CALCULATION FUNDAMENTALS

DUALSPRING

Weight of caliper without bracket:	Approx. 280 kg
Overall dimensions	520 x 570 x 590 mm
Pad width (width for heat calculation):	220 mm
Pad area: (organic)	63,000 mm ² (*)
Max. wear of pad: (organic)	"11 mm (*) (=14 mm thick - lining)"
Nominal coefficient of friction:	$\mu = 0.4$
Total piston area - each caliper half:	74.5 cm ²
Total piston area - each caliper:	149 cm ²
Volume for each caliper at 1 mm stroke:	15 cm ³
Volume for each caliper at 3 mm stroke:	45 cm ³
Actuating time (guide value for calculation):	0.4 sec
Pressure connection/port:	3/8" BSP
Drain connection port:	1/4" BSP
Recommended pipe size:	16/12 mm
Maximum operating pressure	23.0 MPa
Operating temperature range - general	from -20°C to +70°C

(For temperatures outside this range contact Svendborg Brakes)

(*) On each brake pad.

Disc Brake: BSFH 500 DUALspring

Specification

Name: DEB-0500-001-DS-MAR

Date: 23.01.2012

Revision: G

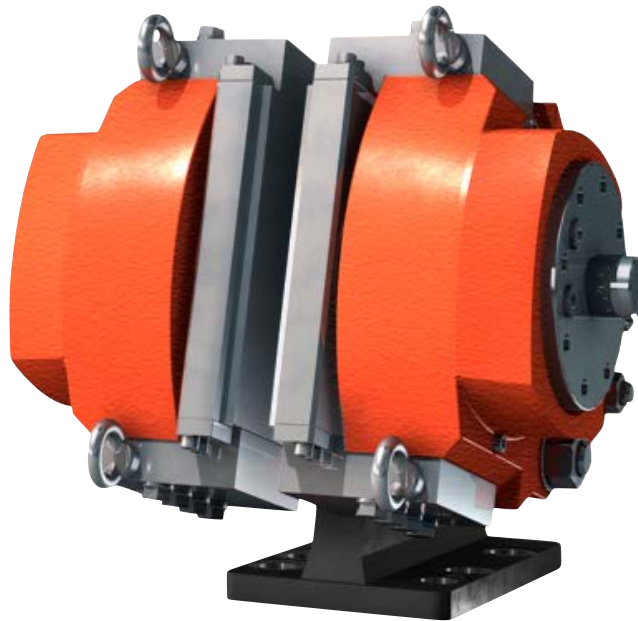

TECHNICAL DATA AND CALCULATION FUNDAMENTALS

CALIPER TYPE	CLAMPING FORCE ¹⁾ [N]		BRAKING FORCE ²⁾ [N]	LOSS OF FORCE PER 1MM [%]	OPERATING PRESSURE ³⁾ MPa	BALANCING PRESSURE ¹⁾ MIN MPa	PAD SURFACE PRESSURE ⁴⁾ [N/mm ²]
	MIN	MAX					
BSFH 507	70,000	74,000	56,000	9.0	8.0	4.82	1.17 - 1.70
BSFH 508	80,000	85,000	64,000	7.0	8.5	5.51	1.35 - 1.95
BSFH 509	90,000	95,000	72,000	6.0	9.0	6.20	1.51 - 2.18
BSFH 510	100,000	105,000	80,000	5.0	10.0	6.89	1.67 - 2.41
BSFH 511	110,000	115,000	88,000	4.5	11.0	7.58	1.83 - 2.64
BSFH 512	120,000	130,000	96,000	8.0	12.0	8.26	2.06 - 2.98
BSFH 514	140,000	153,000	112,000	7.0	14.0	9.64	2.42 - 3.51
BSFH 515	150,000	164,000	120,000	6.0	14.5	10.33	2.60 - 3.76
BSFH 516	160,000	175,000	128,000	6.0	15.0	11.02	2.78 - 4.01
BSFH 520	200,000	218,000	160,000	10.0	19.0	13.77	3.46 - 5.00

¹⁾ All figures are based on 1 mm air gap. (Each side)

²⁾ Braking force is based on a min clamping force, nominal coefficient of friction $\mu = 0.4$ and 2 brake surfaces.

³⁾ The operating pressure is the minimum needed for operating the brake

⁴⁾ Pad pressure for organic / sintered pads respectively (based on max. clamping force)

Disc Brake: BSFH 500 DUALspring

Specification

BRAKING TORQUE

The braking torque M_B is calculated from following formula where:

a is the number of brakes acting on the disc

F_B is the braking force according to table above [N] or calculated from formula

D_o is the brake disc outer diameter [m]

The actual braking torque may vary depending on adjustment of brake and friction coefficient.

$$M_B = a \cdot F_B \cdot \frac{(D_o - 0,22)}{2} \text{ [Nm]}$$

$$F_B = F_C \cdot 2 \cdot \mu$$

CALCULATION FUNDAMENTALS

DUALSPRING

Weight of caliper without bracket:	Approx. 330 kg
Overall dimensions:	430 x 465 x 490 mm
Pad width (width for heat calculation):	220 mm
Pad area: (organic)	63,000 mm ² (*)
Max. wear of pad: (organic)	10 mm (*) "(=37 mm thick incl. brake shoe)"
Pad area: (sintered)	43,600 mm ² (*)
Max. wear of pad: (sintered)	5 mm (*) "(=42 mm thick incl. brake shoe)"
Nominal coefficient of friction:	$\mu = 0.4$
Total piston area - each caliper half:	145 cm ²
Total piston area - each caliper:	290 cm ²
Volume for each caliper at 1 mm stroke:	30 cm ³
Volume for each caliper at 3 mm stroke:	90 cm ³
Actuating time (guide value for calculation):	0.4 sec
Pressure connection/port:	3/8" BSP
Drain connection port:	1/4" BSP
Recommended pipe size:	16/12 mm
Maximum operating pressure	23.0 MPa
Operating temperature range - general	from -20°C to +70°C

(For temperatures outside this range contact Svendborg Brakes)

(*) On each brake pad.

Disc Brake: BSFH 500 MONOspring

Specification

Name: DEB-0500-001-MS-MAR

Date: 23.01.2012

Revision: G

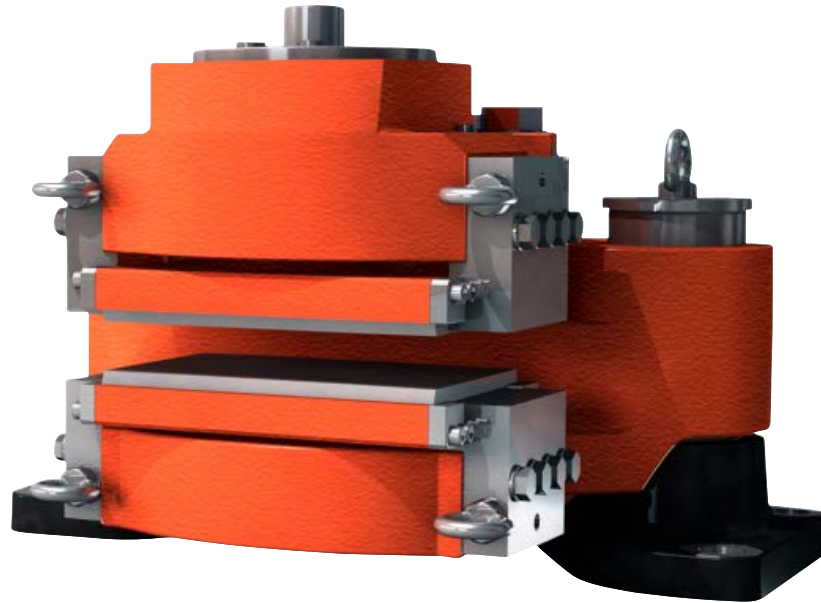

TECHNICAL DATA AND CALCULATION FUNDAMENTALS

CALIPER TYPE	CLAMPING FORCE ¹⁾ [N]		BRAKING FORCE ²⁾ [N]	LOSS OF FORCE PER 1MM [%]	OPERATING PRESSURE ³⁾ MPa	BALANCING PRESSURE ¹⁾ MIN MPa	PAD SURFACE PRESSURE ⁴⁾ [N/mm ²]
	MIN	MAX					
BSFH 507	70,000	74,000	56,000	9.0	8.0	4.82	1.17 - 1.70
BSFH 508	80,000	85,000	64,000	7.0	8.5	5.51	1.35 - 1.95
BSFH 509	90,000	95,000	72,000	6.0	9.0	6.20	1.51 - 2.18
BSFH 510	100,000	105,000	80,000	5.0	10.0	6.89	1.67 - 2.41
BSFH 511	110,000	115,000	88,000	4.5	11.0	7.58	1.83 - 2.64
BSFH 512	120,000	130,000	96,000	8.0	12.0	8.26	2.06 - 2.98
BSFH 514	140,000	153,000	112,000	7.0	14.0	9.64	2.42 - 3.51
BSFH 515	150,000	164,000	120,000	6.0	14.5	10.33	2.60 - 3.76
BSFH 516	160,000	175,000	128,000	6.0	15.0	11.02	2.78 - 4.01
BSFH 520	200,000	218,000	160,000	10.0	19.0	13.77	3.46 - 5.00

¹⁾ All figures are based on 1 mm air gab. (Total)

²⁾ Braking force is based on a min clamping force, nominal coefficient of friction $\mu = 0.4$ and 2 brake surfaces.

³⁾ The operating pressure is the minimum needed for operating the brake

⁴⁾ Pad pressure for organic / sintered pads respectively (based on max. clamping force)

Disc Brake: BSFH 500 MONOspring

Specification

BRAKING TORQUE

The braking torque M_B is calculated from following formula where:

a is the number of brakes acting on the disc

F_B is the braking force according to table above [N] or calculated from formula

D_o is the brake disc outer diameter [m]

The actual braking torque may vary depending on adjustment of brake and friction coefficient.

$$M_B = a \cdot F_B \cdot \frac{(D_o - 0,22)}{2} \text{ [Nm]}$$

$$F_B = F_C \cdot 2 \cdot \mu$$

CALCULATION FUNDAMENTALS

MONOSPRING

Weight of caliper without bracket:	Approx. 500 kg
Overall dimensions:	720 x 540 x 470 mm
Pad width (width for heat calculation):	220 mm
Pad area: (organic)	63,000 mm ² (*)
Max. wear of pad: (organic)	5 mm (*) "(=42 mm thick incl. brake shoe)"
Pad area: (sintered)	43,600 mm ² (*)
Max. wear of pad: (sintered)	5 mm (*) "(=42 mm thick incl. brake shoe)"
Nominal coefficient of friction:	$\mu = 0.4$
Total piston area - each caliper half:	145 cm ²
Total piston area - each caliper:	145 cm ²
Volume for each caliper at 1 mm stroke:	15 cm ³
Volume for each caliper at 3 mm stroke:	45 cm ³
Actuating time (guide value for calculation):	0.4 sec
Pressure connection/port:	3/8" BSP
Drain connection port:	1/4" BSP
Recommended pipe size:	16/12 mm
Maximum operating pressure	23.0 MPa
Operating temperature range - general	from -20°C to +70°C

(For temperatures outside this range contact Svendborg Brakes)

(*) On each brake pad.

Disc Brake: BSFK 500 DUALspring

Specification

Name: DEB-0500-027-DS-MAR

Date: 23.01.2012

Revision: A

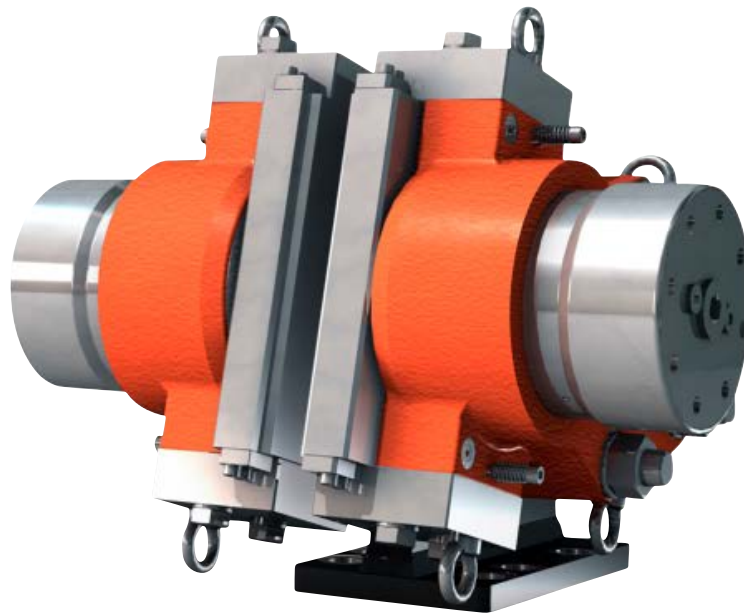

TECHNICAL DATA AND CALCULATION FUNDAMENTALS

CALIPER TYPE	CLAMPING FORCE ¹⁾ [N]		BRAKING FORCE ²⁾ [N]	LOSS OF FORCE PER 1MM [%]	OPERATING PRESSURE ³⁾ MPa	BALANCING PRESSURE ¹⁾ MIN MPa	PAD SURFACE PRESSURE ⁴⁾ [N/mm ²]
	MIN	MAX					
BSFK 520	200,000	220,000	160,000	5.5	13.5	8.57	3.07 - 3.05
BSFK 523	230,000	250,000	184,000	6.5	14.0	9.86	3.48 - 3.45
BSFK 525	250,000	270,000	200,000	5.5	14.5	10.72	3.76 - 3.73
BSFK 527	270,000	295,000	216,000	5.0	15.5	11.58	4.11 - 4.07
BSFK 530 ⁵⁾	300,000	320,000	240,000	12.5	19.0	12.86	4.46 - 4.42
BSFK 535 ⁵⁾	350,000	380,000	280,000	10.0	21.0	15.00	5.30 - 5.25

¹⁾ All figures are based on 1 mm air gap (Each side)

²⁾ Braking force is based on a min clamping force, nominal coefficient of friction $\mu = 0.4$ and 2 brake surfaces.

³⁾ The operating pressure is the minimum needed for operating the brake

⁴⁾ Pad pressure for organic / sintered pads respectively (based on max. clamping force)

⁵⁾ Not recommended for general usage

Disc Brake: BSFK 500 DUALspring

Specification

BRAKING TORQUE

The braking torque M_B is calculated from following formula where:

a is the number of brakes acting on the disc

F_B is the braking force according to table above [N] or calculated from formula

D_o is the brake disc outer diameter [m]

The actual braking torque may vary depending on adjustment of brake and friction coefficient.

$$M_B = a \cdot F_B \cdot \frac{(D_o - 0,23)}{2} \text{ [Nm]}$$

$$F_B = F_C \cdot 2 \cdot \mu$$

CALCULATION FUNDAMENTALS

DUALSPRING

Weight of caliper without bracket:	Approx. 420 kg
Overall dimensions:	720 x 472 x 490 mm
Pad width (width for heat calculation):	230 mm (205 mm)
Pad area: (organic)	71,750 mm ² (*)
Max. wear of pad: (organic)	10 mm (*) "(=47mm thick)"
Pad area: (sintered)	72,400 mm ² (*)
Max. wear of pad: (sintered)	10 mm (*) "(=47mm thick)"
Nominal coefficient of friction:	$\mu = 0.4$
Total piston area - each caliper half:	233 cm ²
Total piston area - each caliper:	466 cm ²
Volume for each caliper at 1 mm stroke:	47 cm ³
Volume for each caliper at 3 mm stroke:	140 cm ³
Actuating time (guide value for calculation):	0.4sec
Pressure connection/port:	3/8" BSP
Drain connection port:	1/4" BSP
Recommended pipe size:	16/12 mm
Maximum operating pressure	23.0 MPa
Operating temperature range - general	from -20°C to +70°C

(For temperatures outside this range contact Svendborg Brakes)

(*) On each brake pad.

Disc Brake: BSFK 500 MONOspring

Specification

Name: DEB-0500-027-MS-MAR

Date: 23.01.2012

Revision: A

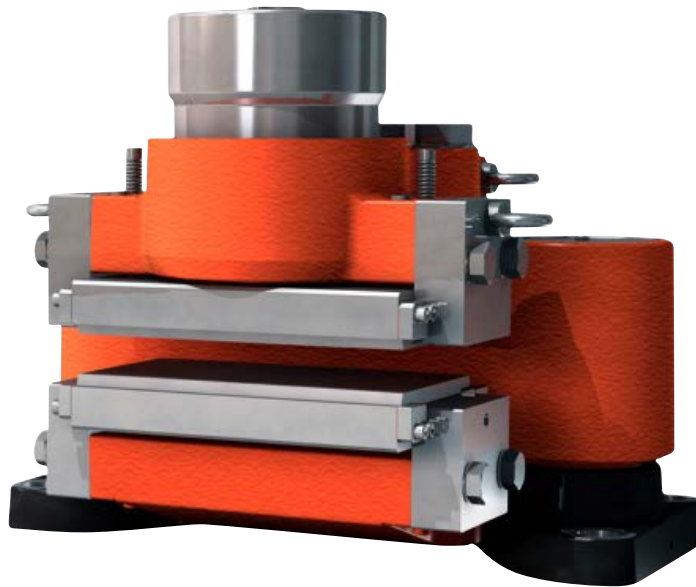

TECHNICAL DATA AND CALCULATION FUNDAMENTALS

CALIPER TYPE	CLAMPING FORCE ¹⁾ [N]		BRAKING FORCE ²⁾ [N]	LOSS OF FORCE PER 1MM [%]	OPERATING PRESSURE ³⁾ MPa	BALANCING PRESSURE ¹⁾ MIN MPa	PAD SURFACE PRESSURE ⁴⁾ [N/mm ²]
	MIN	MAX					
BSFK 520	200,000	220,000	160,000	5.5	13.5	8.57	3.07 - 3.05
BSFK 523	230,000	250,000	184,000	6.5	15.5	9.86	3.48 - 3.45
BSFK 525	250,000	270,000	200,000	5.5	15.5	10.72	3.76 - 3.73
BSFK 527	270,000	295,000	216,000	5.5	16.0	11.58	4.11 - 4.07
BSFK 530 ⁵⁾	300,000	320,000	240,000	13.0	20.5	12.86	4.46 - 4.42
BSFK 535 ⁵⁾	350,000	380,000	280,000	11.0	23.5	15.00	5.30 - 5.25

¹⁾ All figures are based on 1 mm air gap (Total)

²⁾ Braking force is based on a min clamping force, nominal coefficient of friction $\mu = 0.4$ and 2 brake surfaces.

³⁾ The operating pressure is the minimum needed for operating the brake

⁴⁾ Pad pressure for organic / sintered pads respectively (based on max. clamping force)

⁵⁾ Not recommended for general usage

Disc Brake: BSFK 500 MONOspring

Specification

BRAKING TORQUE

The braking torque M_B is calculated from following formula where:

a is the number of brakes acting on the disc

F_B is the braking force according to table above [N] or calculated from formula

D_o is the brake disc outer diameter [m]

The actual braking torque may vary depending on adjustment of brake and friction coefficient.

$$M_B = a \cdot F_B \cdot \frac{(D_o - 0,23)}{2} \text{ [Nm]}$$

$$F_B = F_C \cdot 2 \cdot \mu$$

CALCULATION FUNDAMENTALS

MONOSPRING

Weight of caliper without bracket:	Approx. 550 kg
Overall dimensions:	710 x 532 x 565 mm
Pad width (width for heat calculation):	230 mm (205 mm)
Pad area: (organic)	71,750 mm ² (*)
Max. wear of pad: (organic)	5 mm (*) "(=52mm thick)"
Pad area: (sintered)	72,400 mm ² (*)
Max. wear of pad: (sintered)	5 mm (*) "(=52mm thick)"
Nominal coefficient of friction:	$\mu = 0.4$
Total piston area - each caliper half:	233 cm ²
Total piston area - each caliper:	233 cm ²
Volume for each caliper at 1 mm stroke:	23 cm ³
Volume for each caliper at 3 mm stroke:	70 cm ³
Actuating time (guide value for calculation):	0.4sec
Pressure connection/port:	3/8" BSP
Drain connection port:	1/4" BSP
Recommended pipe size:	16/12 mm
Maximum operating pressure	23.0 MPa
Maximum operating pressure BSFK 535	26.0 MPa
Operating temperature range - general	from -20°C to +70°C

(For temperatures outside this range contact Svendborg Brakes)

(*) On each brake pad.

Disc Brake: BSFB 600 DUALspring

Specification

Name: DEB-0600-016-DS-MAR

Date: 24.05.2012

Revision: A

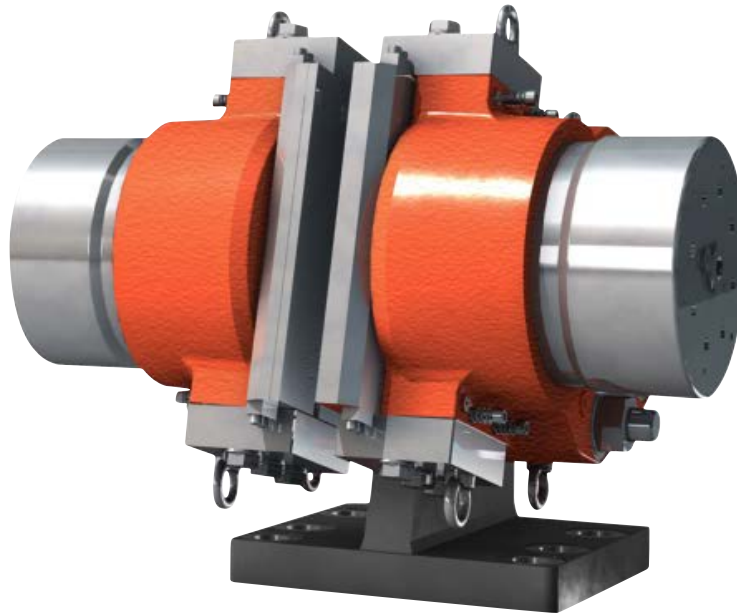

TECHNICAL DATA AND CALCULATION FUNDAMENTALS

CALIPER TYPE	CLAMPING FORCE ¹⁾ [N]		BRAKING FORCE ²⁾ [N]	LOSS OF FORCE PER 1MM [%]	OPERATING PRESSURE ³⁾ MPa	BALANCING PRESSURE ¹⁾ MIN MPa	PAD SURFACE PRESSURE ⁴⁾ [N/mm ²]
	MIN	MAX					
BSFB 630	300,000	320,000	240,000	4.5	11.0	7.23	2.71 - 3.05
BSFB 635	350,000	380,000	280,000	5.5	12.5	8.44	3.05 - 3.22
BSFB 640	400,000	430,000	320,000	4.5	13.5	9.65	3.64 - 4.10
BSFB 645	450,000	490,000	360,000	8.5	16.0	10.85	3.81 - 4.29
BSFB 650	500,000	540,000	400,000	7.5	17.5	12.06	4.58 - 5.14

¹⁾ All figures are based on 2 mm air gap (Each side)

²⁾ Braking force is based on a min clamping force, nominal coefficient of friction $\mu = 0.4$ and 2 brake surfaces.

³⁾ The operating pressure is the minimum needed for operating the brake

⁴⁾ Pad pressure for organic / sintered pads respectively (based on max. clamping force)

Disc Brake: BSFB 600 DUALspring

Specification

BRAKING TORQUE

The braking torque M_B is calculated from following formula where:

a is the number of brakes acting on the disc

F_B is the braking force according to table above [N] or calculated from formula

D_o is the brake disc outer diameter [m]

The actual braking torque may vary depending on adjustment of brake and friction coefficient.

$$M_B = a \cdot F_B \cdot \frac{(D_o - 0,3)}{2} \text{ [Nm]}$$

$$F_B = F_C \cdot 2 \cdot \mu$$

CALCULATION FUNDAMENTALS

DUALSPRING

Weight of caliper without bracket:	Approx. 765 kg
Overall dimensions:	584 x 565 x 797 mm
Pad width (width for heat calculation):	300 mm
Pad area: (organic)	118,000 mm ² (*)
Max. wear of pad: (organic)	10 mm (*) "(=37 mm thick)"
Pad area: (sintered)	105,000 mm ² (*)
Max. wear of pad: (sintered)	10 mm (*) "(=37 mm thick)"
Nominal coefficient of friction:	$\mu = 0.4$
Total piston area - each caliper half:	415 cm ²
Total piston area - each caliper:	830 cm ²
Volume for each caliper at 1 mm stroke:	83 cm ³
Volume for each caliper at 3 mm stroke:	249 cm ³
Actuating time (guide value for calculation):	0.3 - 0,5 sec
Pressure connection/port:	1/2" BSP
Drain connection port:	1/4" BSP
Recommended pipe size:	16 mm
Maximum operating pressure	18.5 MPa
Operating temperature range - general	from -20°C to +70°C

(For temperatures outside this range contact Svendborg Brakes)

(C=disc thickness)

(*) On each brake pad.

Disc Brake: BSFB 600 MONOspring

Specification

Name: DEB-0600-016-MS-MAR

Date: 24.05.2012

Revision: A

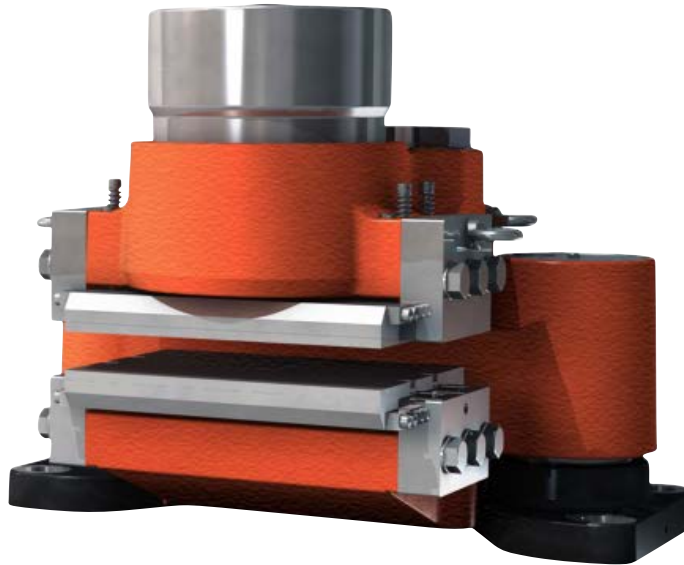

TECHNICAL DATA AND CALCULATION FUNDAMENTALS

CALIPER TYPE	CLAMPING FORCE ¹⁾ [N]		BRAKING FORCE ²⁾ [N]	LOSS OF FORCE PER 1MM [%]	OPERATING PRESSURE ³⁾ MPa	BALANCING PRESSURE ¹⁾ MIN MPa	PAD SURFACE PRESSURE ⁴⁾ [N/mm ²]
	MIN	MAX					
BSFB 630	300,000	330,000	240,000	7.5	12.5	7.23	2.80 - 3.14
BSFB 635	350,000	380,000	280,000	5.0	13.5	8.44	3.05 - 3.22
BSFB 638	350,000	380,000	280,000	5.0	13.5	8.44	3.05 - 3.22
BSFB 640	400,000	430,000	320,000	4.5	15.0	9.65	3.64 - 4.10

¹⁾ All figures are based on 3 mm air gap (Total)

²⁾ Braking force is based on a min clamping force, nominal coefficient of friction $\mu = 0.4$ and 2 brake surfaces.

³⁾ The operating pressure is the minimum needed for operating the brake

⁴⁾ Pad pressure for organic / sintered pads respectively (based on max. clamping force)

Disc Brake: BSFB 600 MONOspring

Specification

BRAKING TORQUE

The braking torque M_B is calculated from following formula where:

a is the number of brakes acting on the disc

F_B is the braking force according to table above [N] or calculated from formula

D_o is the brake disc outer diameter [m]

The actual braking torque may vary depending on adjustment of brake and friction coefficient.

$$M_B = a \cdot F_B \cdot \frac{(D_o - 0,3)}{2} \text{ [Nm]}$$

$$F_B = F_C \cdot 2 \cdot \mu$$

CALCULATION FUNDAMENTALS

MONOSPRING

Weight of caliper without bracket:	Approx. 850 kg
Overall dimensions:	840 x 620 x 620 mm
Pad width (width for heat calculation):	300 mm
Pad area: (organic)	118,000 mm ² (*)
Max. wear of pad: (organic)	10 mm (*) "(=37 mm thick)"
Pad area: (sintered)	105,000 mm ² (*)
Max. wear of pad: (sintered)	10 mm (*) "(=37 mm thick)"
Nominal coefficient of friction:	$\mu = 0.4$
Total piston area - each caliper half:	415 cm ²
Total piston area - each caliper:	415 cm ²
Volume for each caliper at 1 mm stroke:	41 cm ³
Volume for each caliper at 3 mm stroke:	124 cm ³
Actuating time (guide value for calculation):	0.3 - 0,5 sec
Pressure connection/port:	1/2" BSP
Drain connection port:	1/4" BSP
Recommended pipe size:	16 mm
Maximum operating pressure	18.5 MPa
Operating temperature range - general	from -20°C to +70°C

(For temperatures outside this range contact Svendborg Brakes)

(*) On each brake pad.

Disc Brake: BSFA 1000 MONOspring

Specification

Name: DEB-1000-001-MS-MAR

Date: 17.05.2010

Revision: A

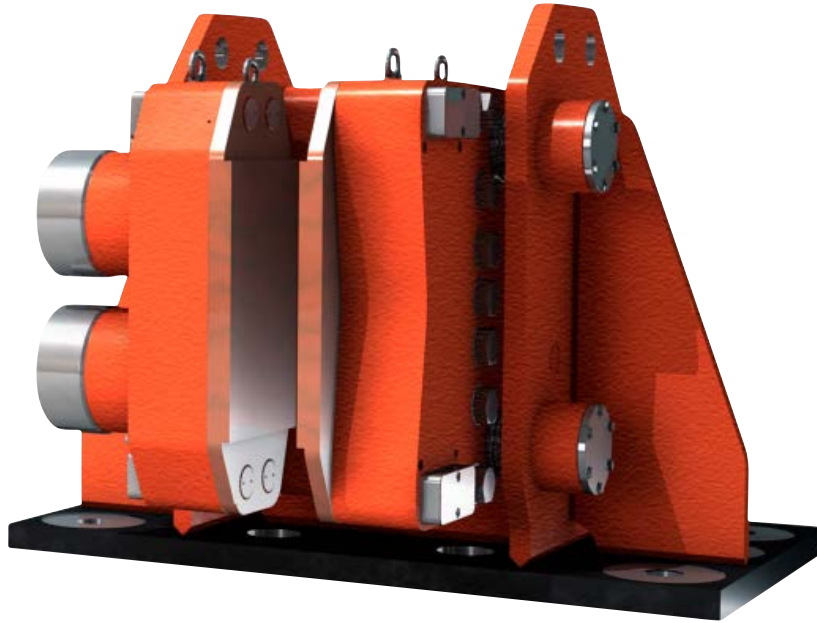

TECHNICAL DATA AND CALCULATION FUNDAMENTALS

CALIPER TYPE	CLAMPING FORCE ¹⁾ [N]		BRAKING FORCE ²⁾ [N]	LOSS OF FORCE PER 1MM [%]	OPERATING PRESSURE ³⁾ MPa	BALANCING PRESSURE ¹⁾ MIN MPa	PAD SURFACE PRESSURE ⁴⁾ [N/mm ²]
	MIN	MAX					
BSFA 1060	600,000	640,000	480,000	8.5	13.0	7.36	4.18
BSFA 1070	700,000	740,000	560,000	8.5	14.0	8.58	4.84
BSFA 1080	800,000	850,000	640,000	10.5	17.0	9.81	5.56
BSFA 1090	900,000	950,000	720,000	9.5	18.0	11.03	6.21
BSFA 1100	1.000,000	1.050,000	800,000	8.5	20.5	12.26	6.86
BSFA 1110	1.100,000	1.160,000	880,000	8.0	23.5	13.49	7.58

¹⁾ All figures are based on 2 mm air gap (total) and 2 spring packs.

²⁾ Braking force is based on a min clamping force, nominal coefficient of friction $\mu = 0.4$ and 2 brake surfaces.

³⁾ The operating pressure is the minimum needed for operating the brake

⁴⁾ Pad pressure for organic / sintered pads respectively (based on max. clamping force)

Bracket is not part of brake.

Disc Brake: BSFA 1000 MONOspring

Specification

BRAKING TORQUE

The braking torque M_B is calculated from following formula where:

a is the number of brakes acting on the disc

F_B is the braking force according to table above [N] or calculated from formula

D_o is the brake disc outer diameter [m]

The actual braking torque may vary depending on adjustment of brake and friction coefficient.

$$M_B = a \cdot F_B \cdot \frac{(D_o - 0,3)}{2} \text{ [Nm]}$$

$$F_B = F_C \cdot 2 \cdot \mu$$

CALCULATION FUNDAMENTALS

Weight of complete caliper incl. pads and without bracket:	1,400 - 1600 kg depending on the disc thickness
Disc thickness:	80 - 135 mm (depending on type)
Overall caliper dimensions:	766 - 859 x 800 x 615mm (depending on disc thickness)
Pad width:	300 mm
Pad friction area: (organic)	153,000 mm ² (*)
Max. wear of pad:	5 mm (*)
Nominal coefficient of friction:	$\mu = 0.4$
Total piston area - each caliper half:	$2 \times 40,800 \text{ mm}^2 = 81,600 \text{ mm}^2$
Volume for each caliper half at 1 mm stroke:	81.6 cm ³
Volume for each caliper at 3 mm stroke:	245 cm ³
Actuating time (guide value for calculation):	0.4sec
Pressure connection (port size):	3/4" BSP
Drain connection R (port size):	1/4" BSP
Recommended hydraulic pipe size OD:	16 mm
Max. operating pressure	23,0 MPa
Operating temperature range - general	from -20°C to +70°C

(For temperatures outside this range contact Svendborg Brakes)

(*) On each brake pad.

Disc Brake: BSAB 75 DUAL-ACTION

Specification

Name: DEB-0075-002-DA-MAR
Date: 07.03.2008
Revision: A

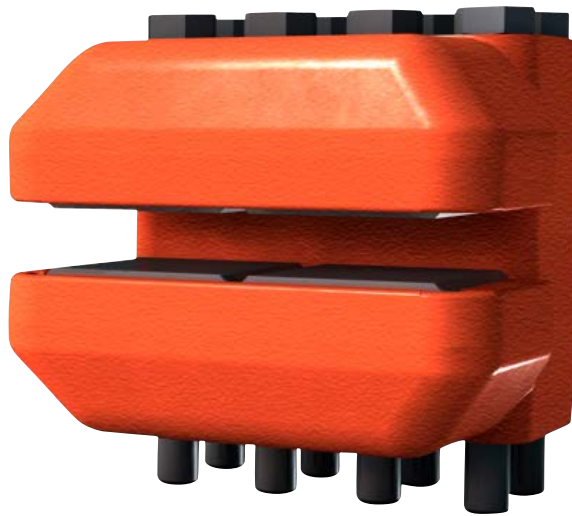

TECHNICAL DATA AND CALCULATION FUNDAMENTALS

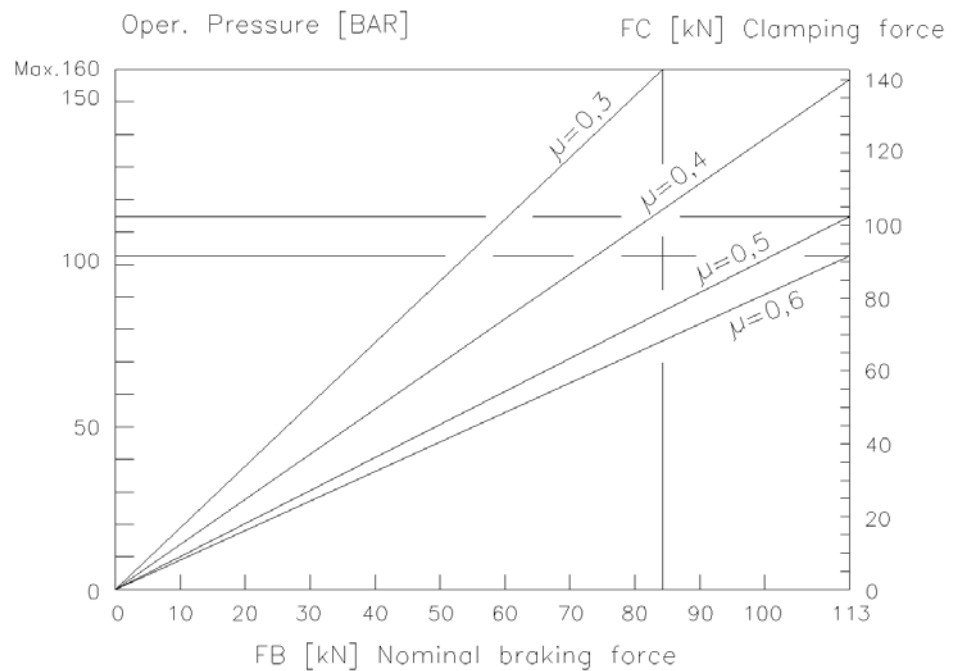

Disc Brake: BSAB 75 DUAL-ACTION

Specification

BRAKING TORQUE

The braking torque M_B is calculated from following formula where:
 a is the number of brakes acting on the disc
 F_B is the braking force according to table above [N] or calculated from formula
 D_o is the brake disc outer diameter [m]
 F_C is the clamping force [N]
 A [cm²], P [bar] and μ see values below
 The actual braking torque may vary depending on friction coefficient.

$$M_B = a \cdot F_B \cdot \frac{(D_o - 0,102)}{2} \text{ [Nm]}$$

$$F_B = F_C \cdot 2 \cdot \mu \text{ [N]}$$

$$F_C = A \cdot P \cdot 10 \text{ [N]}$$

CALCULATION FUNDAMENTALS

Weight of caliper without bracket:	Approx. 60 kg
Overall dimensions:	220 x 240 x 260 mm
Pad width:	102 mm
Pad area: (organic)	20,300 mm ² (*)
Max. wear of pad: (organic)	7 mm (*) "(=11 mm thick)"
Pad area: (sinter)	16,350 mm ² (*)
Max. wear of pad: (sinter)	6 mm (*) "(=12 mm thick)"
Nominal coefficient of friction:	$\mu = 0.4$
Total piston area - each caliper half:	A=88 cm ²
Total piston area - each caliper:	176 cm ²
Volume for each caliper at 1 mm stroke:	18 cm ³
Volume for each caliper at 3 mm stroke:	54 cm ³
Actuating time (guide value for calculation):	0.4 sec
Pressure connection/port:	1/4" BSP
Drain connection/port:	1/4" BSP
Max. operating pressure:	16 MPa
Recommended pipe size:	10/8 mm

Operating temperature range - general from -20°C to +70°C

Operating temperature range - wind turbine from -40°C to +60°C

(For temperatures outside this range contact Svendborg Brakes)

(*) On each brake pad.

Disc Brake: BSAB 90 DUAL-ACTION

Specification

Name: DEB-0090-001-DA-MAR
Date: 09.12.2009
Revision: B



TECHNICAL DATA AND CALCULATION FUNDAMENTALS

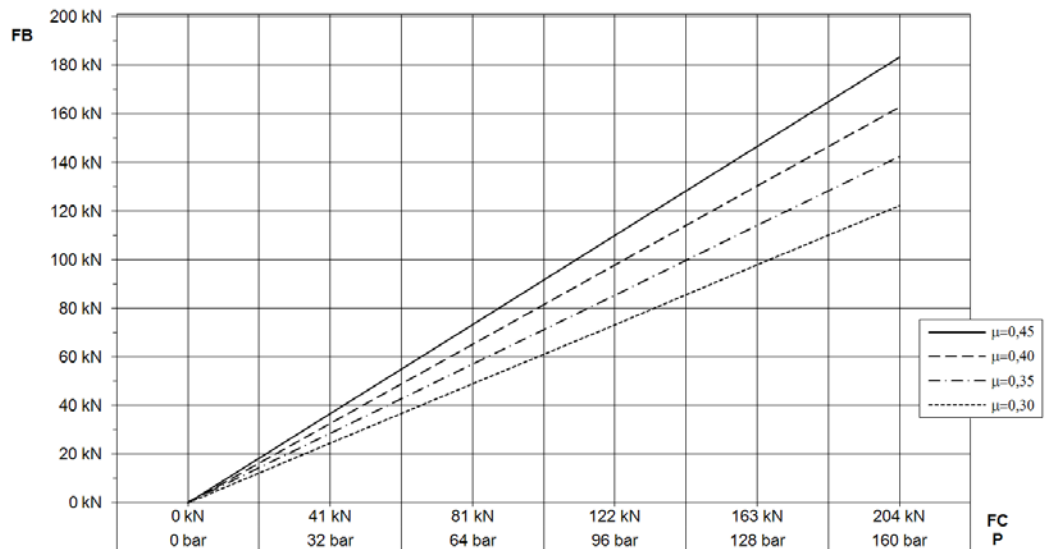

Disc Brake: BSAB 90 DUAL-ACTION

Specification

BRAKING TORQUE

The braking torque M_B is calculated from following formula where:
 a is the number of brakes acting on the disc
 F_B is the braking force according to table above [N] or calculated from formula
 D_o is the brake disc outer diameter [m]
 F_C is the clamping force [N]
 A [cm²], P [bar] and μ see values below
 The actual braking torque may vary depending on friction coefficient.

$$M_B = a \cdot F_B \cdot \frac{(D_o - 0,102)}{2} \text{ [Nm]}$$

$$F_B = F_C \cdot 2 \cdot \mu \text{ [N]}$$

$$F_C = A \cdot P \cdot 10 \text{ [N]}$$

CALCULATION FUNDAMENTALS

Weight of caliper without bracket:	Approx. 60 kg
Overall dimensions:	220 x 240 x 260 mm
Pad width:	102 mm
Pad area: (organic)	20,300 mm ² (*)
Max. wear of pad: (organic)	7 mm (*) "(=14 mm thick)"
Pad area: (sinter)	16,350 mm ² (*)
Max. wear of pad: (sinter)	6 mm (*) "(=12 mm thick)"
Nominal coefficient of friction:	$\mu = 0.4$
Total piston area - each caliper half:	A=127 cm ²
Total piston area - each caliper:	254 cm ²
Volume for each caliper at 1 mm stroke:	25 cm ³
Volume for each caliper at 3 mm stroke:	76 cm ³
Actuating time (guide value for calculation):	0.4 sec
Pressure connection/port:	1/4" BSP
Drain connection/port:	1/4" BSP
Max. operating pressure:	15.7 MPa
Recommended pipe size:	10/8 mm

Operating temperature range - general from -20°C to +70°C

Operating temperature range - wind turbine from -40°C to +60°C

(For temperatures outside this range contact Svendborg Brakes)

(*) On each brake pad.

Disc Brake: BSAB 120 DUAL-ACTION

Specification

Name: DEB-0120-001-DA-MAR
Date: 03.12.2009
Revision: B

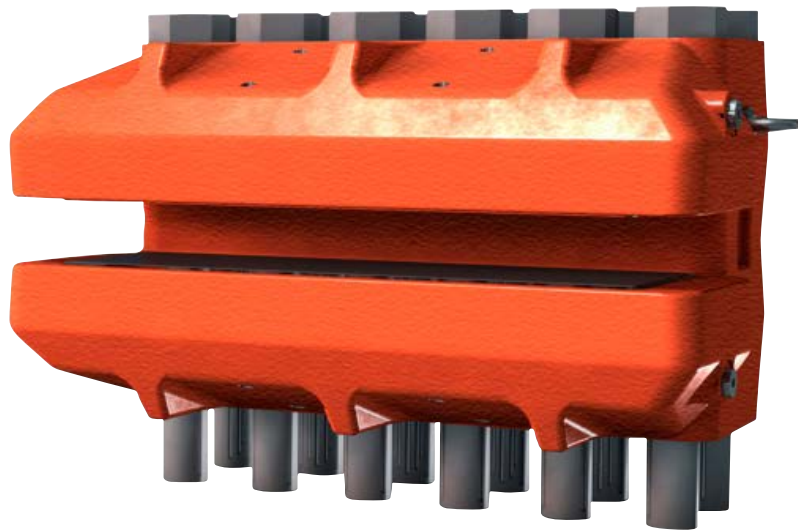

TECHNICAL DATA AND CALCULATION FUNDAMENTALS

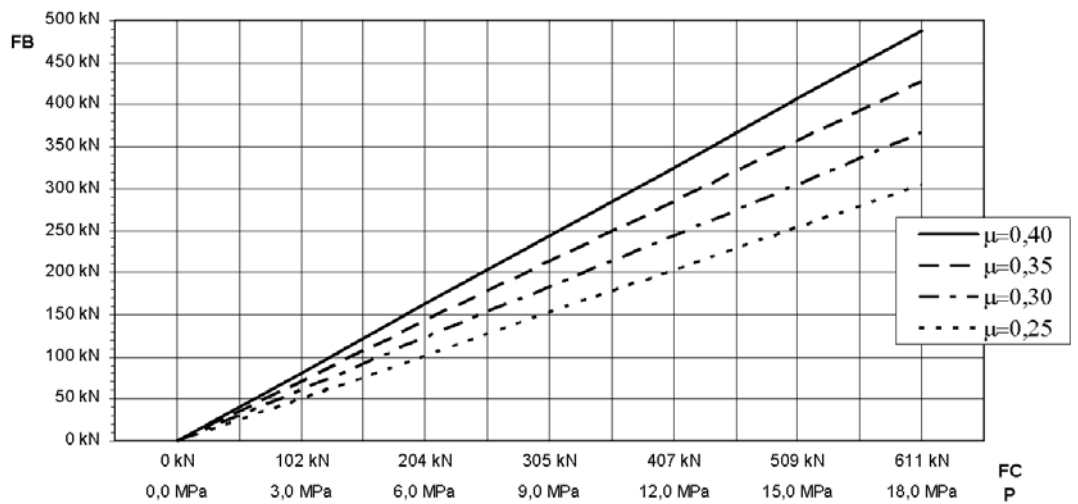

Disc Brake: BSAB 120 DUAL-ACTION

Specification

BRAKING TORQUE

The braking torque M_B is calculated from following formula where:
 a is the number of brakes acting on the disc
 F_B is the braking force according to table above [N] or calculated from formula
 D_o is the brake disc outer diameter [m]
 F_C is the clamping force [N]
 A [cm²], P [bar] and μ see values below
 The actual braking torque may vary depending on friction coefficient.

$$M_B = a \cdot F_B \cdot \frac{(D_o - 0,136)}{2} \text{ [Nm]}$$

$$F_B = F_C \cdot 2 \cdot \mu \text{ [N]}$$

$$F_C = A \cdot P \cdot 10 \text{ [N]}$$

CALCULATION FUNDAMENTALS

Weight of caliper without bracket:	Approx. 210 kg
Overall dimensions:	500 x 310 x 274 mm
Pad width:	138 mm
Pad area: (organic)	50,000 mm ² (*)
Max. wear of pad: (organic)	7 mm (*) "(=14 mm thick)"
Nominal coefficient of friction:	$\mu = 0.4$
Total piston area - each caliper half:	$A=339.3 \text{ cm}^2$
Total piston area - each caliper:	678.6 cm ²
Volume for each caliper at 1 mm stroke:	67.86 cm ³
Volume for each caliper at 3 mm stroke:	203.5 cm ³
Actuating time (guide value for calculation):	0.8 sec
Pressure connection/port:	1/4" BSP
Drain connection/port:	1/4" BSP
Max. operating pressure:	16.0 MPa
Recommended pipe size:	10 mm

Operating temperature range - general from -20°C to +70°C
 Operating temperature range - wind turbine from -40°C to +60°C

(For temperatures outside this range contact Svendborg Brakes)

(*) On each brake pad.

Disc Brake: BSAK 300 DUAL-ACTION

Specification

Name: DEB-0300-043-DA-MAR
Date: 15.05.2009
Revision: A

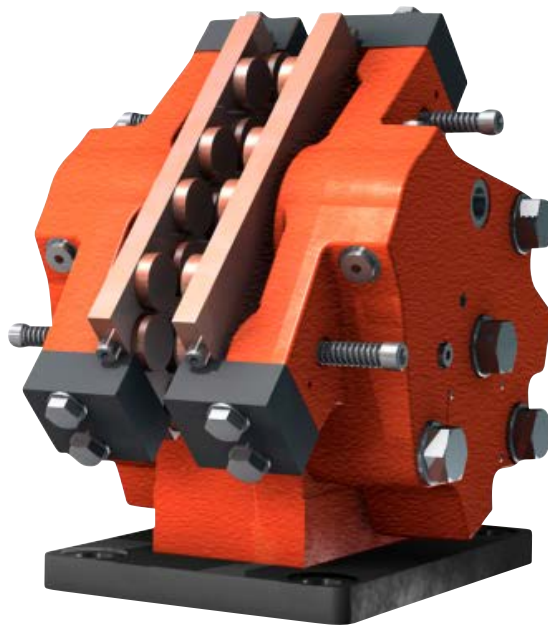

TECHNICAL DATA AND CALCULATION FUNDAMENTALS

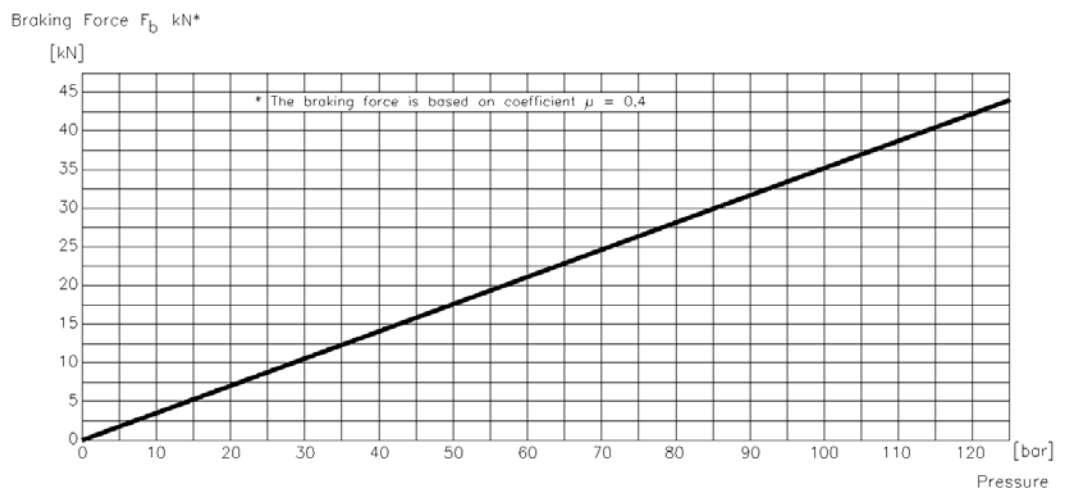

Disc Brake: BSAK 300 DUAL-ACTION

Specification

BRAKING TORQUE

The braking torque M_B is calculated from following formula where:
 a is the number of brakes acting on the disc
 F_B is the braking force according to table above [N] or calculated from formula
 D_o is the brake disc outer diameter [m]
 F_C is the clamping force [N]
 A [cm²], P [bar] and μ see values below
 The actual braking torque may vary depending on friction coefficient.

$$M_B = a \cdot F_B \cdot \frac{(D_o - 0,13)}{2} \text{ [Nm]}$$

$$F_B = F_C \cdot 2 \cdot \mu \text{ [N]}$$

$$F_C = A \cdot P \cdot 10 \text{ [N]}$$

CALCULATION FUNDAMENTALS

DUAL-ACTION

Weight of caliper without bracket:	Approx. 55 kg
Overall dimensions:	331 x 320 x 321 mm
Pad width:	130 mm
Pad area: (organic)	29,000 mm ² (*)
Max. wear of pad: (organic)	10 mm (*) "(=14 mm thick)"
Pad area: (sinter)	20,000 mm ² (*)
Max. wear of pad: (sinter)	7 mm (*) "(=17 mm thick)"
Nominal coefficient of friction:	$\mu = 0.4$
Total piston area - each caliper half:	$A=44.2 \text{ cm}^2$
Total piston area - each caliper:	88.4 cm^2
Volume for each caliper at 1 mm stroke:	8.8 cm^3
Volume for each caliper at 3 mm stroke:	24.6 cm^3
Actuating time (guide value for calculation):	0.3 sec
Pressure connection/port:	1/4" BSP
Drain connection/port:	1/8" BSP
Max. operating pressure:	12.5 MPa
Recommended pipe size:	10/8 mm

Operating temperature range - general from -20°C to +70°C
 Operating temperature range - wind turbine from -40°C to +60°C

(For temperatures outside this range contact Svendborg Brakes)

(*) On each brake pad.

Disc Brake: BSAK 300 MONO-ACTION

Specification

Name: DEB-0300-043-DA-MAR

Date: 15.05.2009

Revision: A

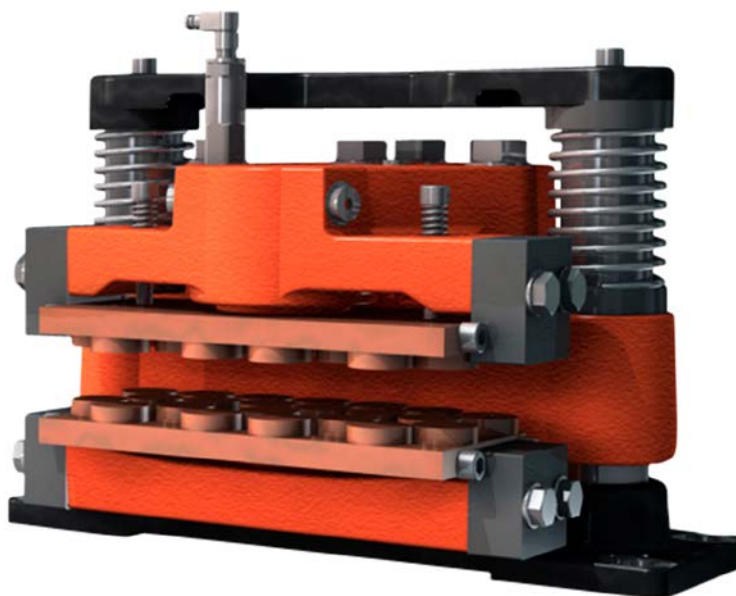

TECHNICAL DATA AND CALCULATION FUNDAMENTALS

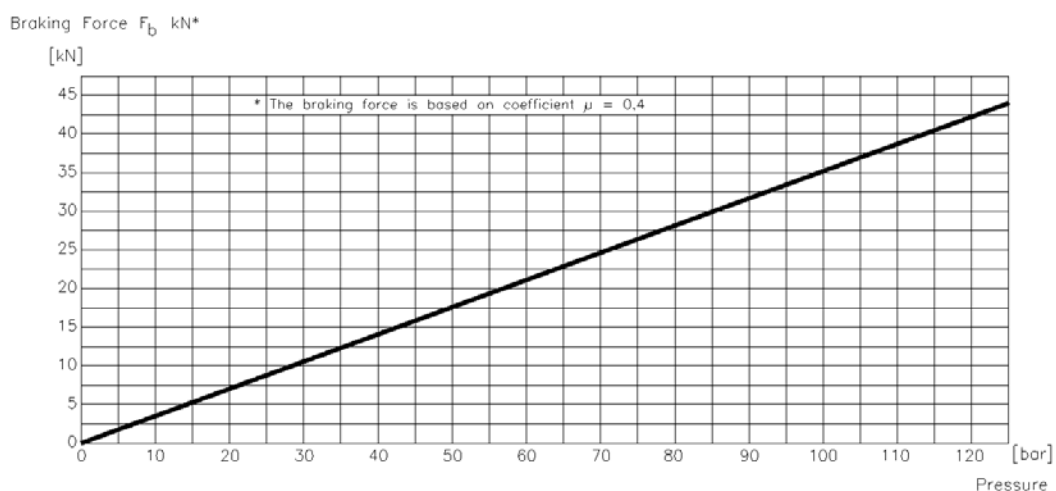

Disc Brake: BSAK 300 MONO-ACTION

Specification

BRAKING TORQUE

The braking torque M_B is calculated from following formula where:
 a is the number of brakes acting on the disc
 F_B is the braking force according to table above [N] or calculated from formula
 D_o is the brake disc outer diameter [m]
 F_C is the clamping force [N]
 A [cm²], P [bar] and μ see values below
 The actual braking torque may vary depending on friction coefficient.

$$M_B = a \cdot F_B \cdot \frac{(D_o - 0,13)}{2} \text{ [Nm]}$$

$$F_B = F_C \cdot 2 \cdot \mu \text{ [N]}$$

$$F_C = A \cdot P \cdot 10 \text{ [N]}$$

CALCULATION FUNDAMENTALS

MONO-ACTION

Weight of caliper without bracket:	Approx. 75 kg
Overall dimensions:	260 x 420 x 300 mm
Pad width:	130 mm
Pad area: (organic)	29,000 mm ² (*)
Max. wear of pad: (organic)	5 mm (*) "(=19 mm thick)"
Pad area: (sinter)	20,000 mm ² (*)
Max. wear of pad: (sinter)	5 mm (*) "(=19 mm thick)"
Nominal coefficient of friction:	$\mu = 0.4$
Total piston area - each caliper half:	$A=44.2 \text{ cm}^2$
Total piston area - each caliper:	44.2 cm^2
Volume for each caliper at 1 mm stroke:	4.4 cm^3
Volume for each caliper at 3 mm stroke:	13.2 cm^3
Actuating time (guide value for calculation):	0.3 sec
Pressure connection/port:	1/4" BSP
Drain connection/port:	1/8" BSP
Max. operating pressure:	12.5 MPa
Recommended pipe size:	10/8 mm

Operating temperature range - general from -20°C to +70°C
 Operating temperature range - wind turbine from -40°C to +60°C

(For temperatures outside this range contact Svendborg Brakes)

(*) On each brake pad.

Disc Brake: BSAK 3000 DUAL-ACTION

Specification

Name: DEB-3000-020-DA-MAR
Date: 15.05.2009
Revision: A

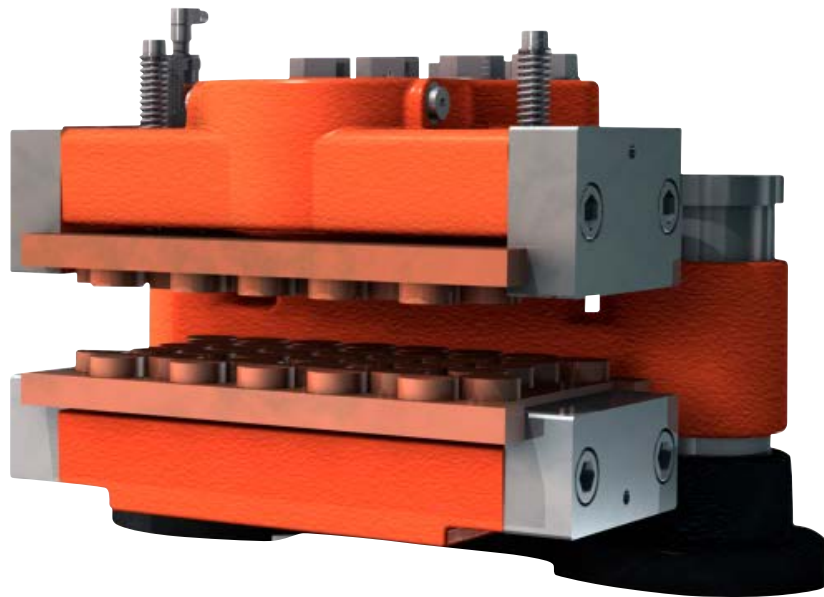

TECHNICAL DATA AND CALCULATION FUNDAMENTALS

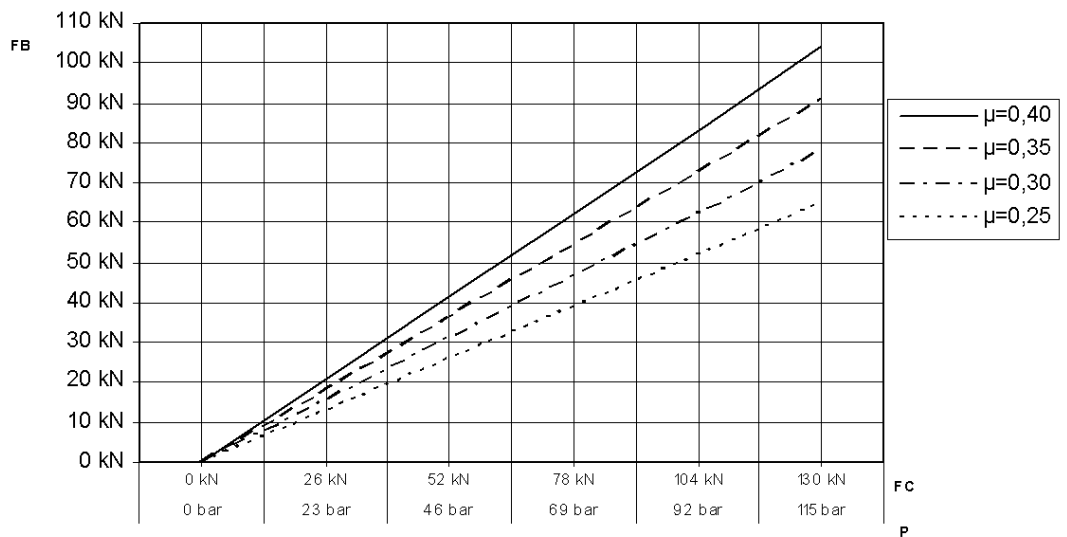

Disc Brake: BSAK 3000 DUAL-ACTION

Specification

BRAKING TORQUE

The braking torque M_B is calculated from following formula where:
 a is the number of brakes acting on the disc
 F_B is the braking force according to table above [N] or calculated from formula
 D_0 is the brake disc outer diameter [m]
 F_C is the clamping force [N]
 A [cm²], P [bar] and μ see values below
 The actual braking torque may vary depending on friction coefficient.

$$M_B = a \cdot F_B \cdot \frac{(D_0 - 0,2)}{2} \text{ [Nm]}$$

$$F_B = F_C \cdot 2 \cdot \mu \text{ [N]}$$

$$F_C = A \cdot P \cdot 10 \text{ [N]}$$

CALCULATION FUNDAMENTALS

DUAL-ACTION

Weight of caliper without bracket:	Approx. 130 kg
Pad width:	200 mm
Pad area: (organic)	59,600 mm ² (*)
Max. wear of pad: (organic)	10 mm (*) "(=22 mm thick)"
Pad area: (sinter)	36,000 mm ² (*)
Max. wear of pad: (sinter)	10 mm (*) "(=22 mm thick)"
Nominal coefficient of friction:	$\mu = 0.4$
Total piston area - each caliper half:	$A=113.1 \text{ cm}^2$
Total piston area - each caliper:	226.2 cm ²
Volume for each caliper at 1 mm stroke:	22.6 cm ³
Volume for each caliper at 3 mm stroke:	67.9 cm ³
Actuating time (guide value for calculation):	0.3 sec
Pressure connection/port:	1/4" BSP
Max. operating pressure:	11.5 MPa

Operating temperature range - general from -20°C to +70°C
 Operating temperature range - wind turbine from -40°C to +60°C

(For temperatures outside this range contact Svendborg Brakes)

(*) On each brake pad.

Disc Brake: BSAK 3000 MONO-ACTION

Specification

Name: DEB-0300-043-DA-MAR
Date: 15.05.2009
Revision: A

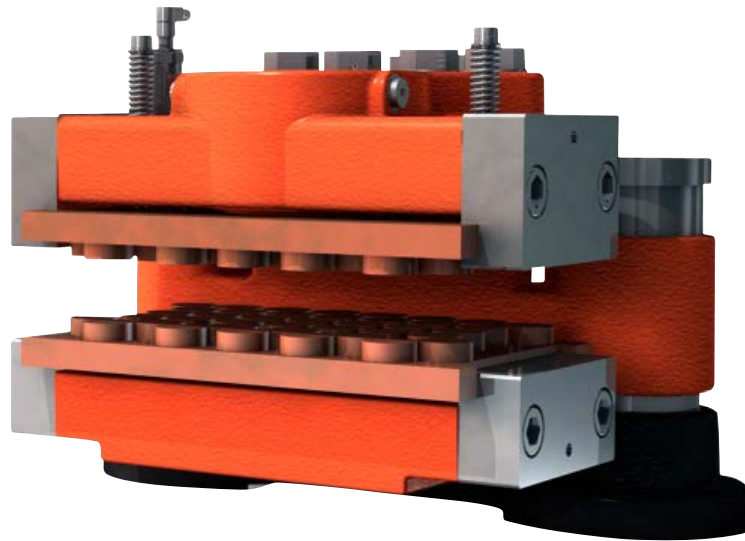

TECHNICAL DATA AND CALCULATION FUNDAMENTALS

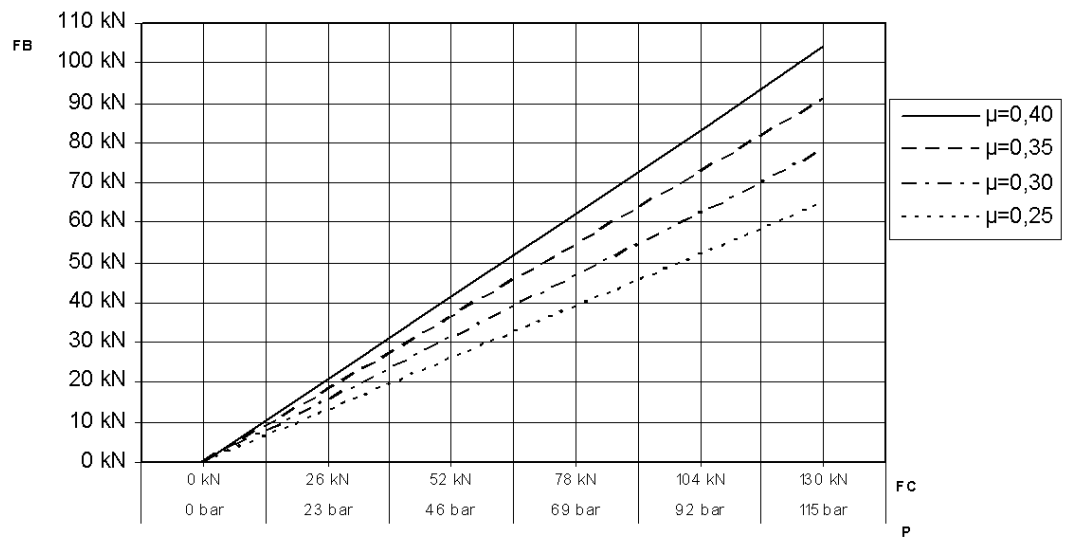

Disc Brake: BSAK 3000 MONO-ACTION

Specification

BRAKING TORQUE

The braking torque M_B is calculated from following formula where:

a is the number of brakes acting on the disc

F_B is the braking force according to table above [N] or calculated from formula

D_o is the brake disc outer diameter [m]

F_C is the clamping force [N]

A [cm²], P [bar] and μ see values below

The actual braking torque may vary depending on friction coefficient.

$$M_B = a \cdot F_B \cdot \frac{(D_o - 0,2)}{2} \text{ [Nm]}$$

$$F_B = F_C \cdot 2 \cdot \mu \text{ [N]}$$

$$F_C = A \cdot P \cdot 10 \text{ [N]}$$

CALCULATION FUNDAMENTALS

MONO-ACTION

Weight of caliper without bracket:	Approx. 160 kg
Pad width:	200 mm
Pad area: (organic)	59,600 mm ² (*)
Max. wear of pad: (organic)	5 mm (*) "(=23 mm thick)"
Pad area: (sinter)	36,000 mm ² (*)
Max. wear of pad: (sinter)	5 mm (*) "(=23 mm thick)"
Nominal coefficient of friction:	$\mu = 0.4$
Total piston area - each caliper half:	$A=113.1 \text{ cm}^2$
Total piston area - each caliper:	113.1 cm ²
Volume for each caliper at 1 mm stroke:	11.31 cm ³
Volume for each caliper at 3 mm stroke:	33.9 cm ³
Actuating time (guide value for calculation):	0.3 sec
Pressure connection/port:	1/4" BSP
Max. operating pressure:	11.5 MPa

Operating temperature range - general from -20°C to +70°C

Operating temperature range - wind turbine from -40°C to +60°C

(For temperatures outside this range contact Svendborg Brakes)

(*) On each brake pad.

Disc Brake: BSAL 3000 MONO-ACTION

Specification

Name: DEB-3000-030-MA-MAR
Date: 07.03.2012
Revision: -

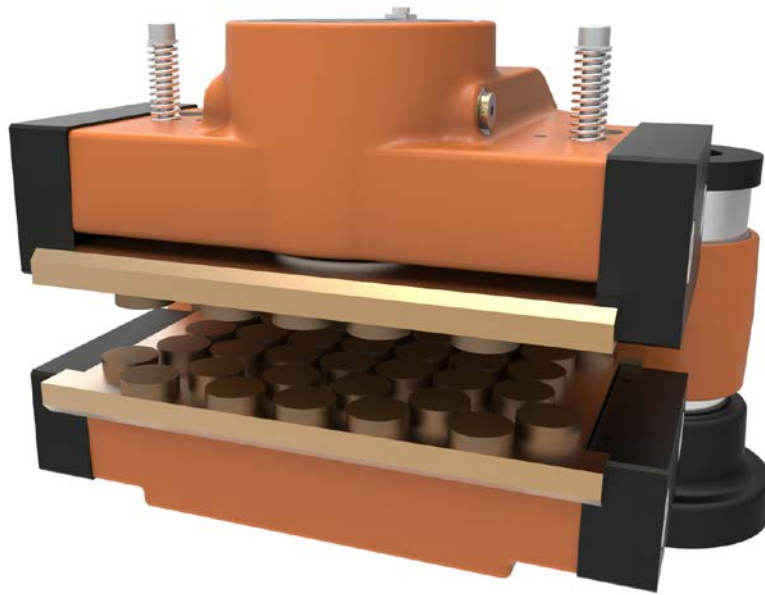

TECHNICAL DATA AND CALCULATION FUNDAMENTALS

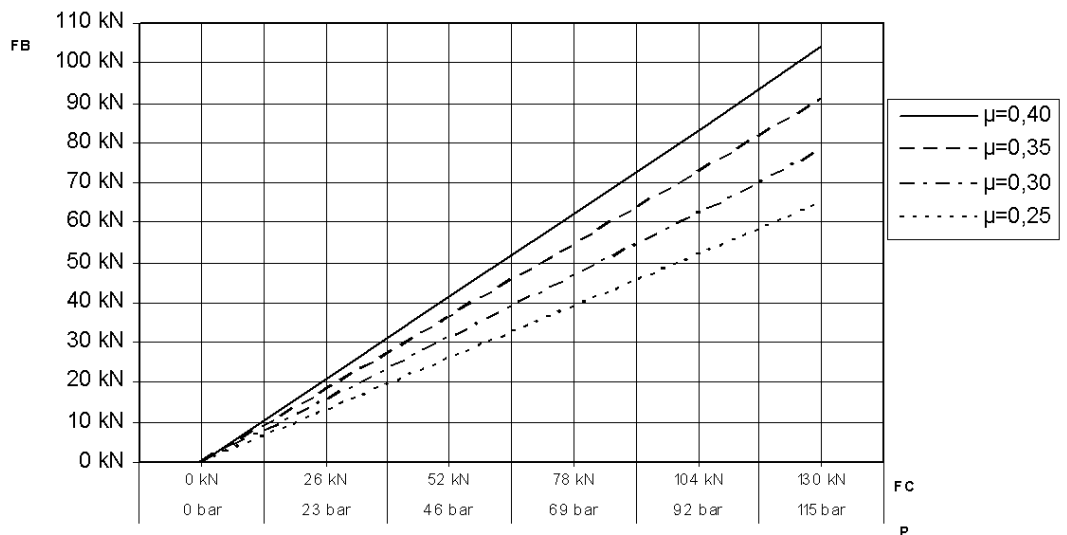

Disc Brake: BSAL 3000 MONO-ACTION

Specification

BRAKING TORQUE

The braking torque M_B is calculated from following formula where:

a is the number of brakes acting on the disc

F_B is the braking force according to table above [N] or calculated from formula

D_o is the brake disc outer diameter [m]

F_C is the clamping force [N]

A [cm²], P [bar] and μ see values below

The actual braking torque may vary depending on adjustment of brake and friction coefficient.

$$M_B = a \cdot F_B \cdot \frac{(D_o - 0,2)}{2} \text{ [Nm]}$$

$$F_B = F_C \cdot 2 \cdot \mu \text{ [N]}$$

$$F_C = A \cdot P \cdot 10 \text{ [N]}$$

CALCULATION FUNDAMENTALS

MONO-ACTION

Weight of caliper without bracket:	Approx. 180 kg
Pad width:	200 mm
Pad area: (organic)	59,600 mm ² (*)
Max. wear of pad: (organic)	5 mm (*) "(=23 mm thick)"
Pad area: (sinter)	36,000 mm ² (*)
Max. wear of pad: (sinter)	5 mm (*) "(=23 mm thick)"
Nominal coefficient of friction:	$\mu = 0.4$
Total piston area - each caliper half:	$A=113.1 \text{ cm}^2$
Total piston area - each caliper:	113.1 cm ²
Volume for each caliper at 1 mm stroke:	11.31 cm ³
Volume for each caliper at 3 mm stroke:	33.9 cm ³
Actuating time (guide value for calculation):	0.3 sec
Pressure connection/port:	1/4" BSP, 1/8" BSP
Max. operating pressure:	11.5 MPa

Operating temperature range - general from -20°C to +70°C

Operating temperature range - wind turbine from -40°C to +60°C

(For temperatures outside this range contact Svendborg Brakes)

(*) On each brake pad.

Disc Brake: BSAC 120 DUAL-ACTION

Specification

Name: DEB-0120-004-DA-MAR
Date: 03.07.2012
Revision: -



TECHNICAL DATA AND CALCULATION FUNDAMENTALS

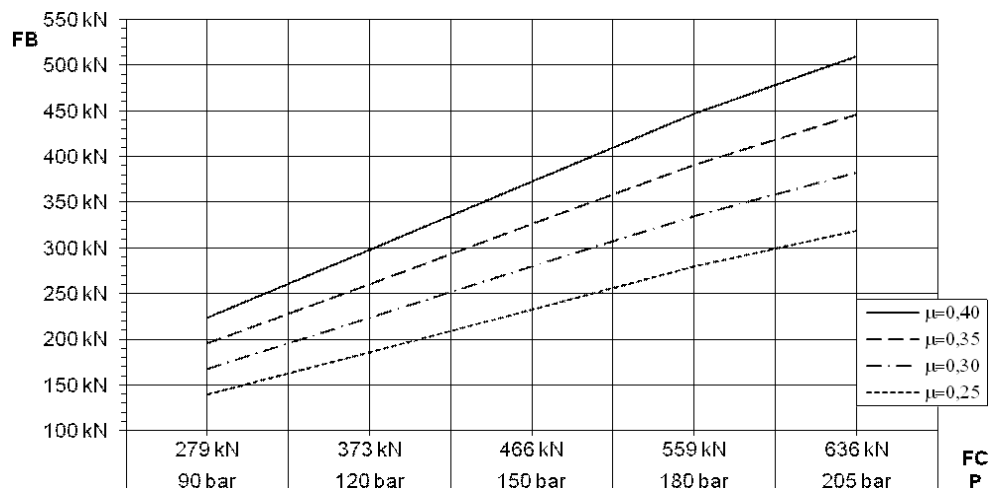

Disc Brake: BSAC 120 DUAL-ACTION

Specification

BRAKING TORQUE

The braking torque M_B is calculated from following formula where:
 a is the number of brakes acting on the disc
 F_B is the braking force according to table above [N] or calculated from formula
 D_o is the brake disc outer diameter [m]
 F_C is the clamping force [N]
 A [cm²], P [bar] and μ see values below
 The actual braking torque may vary depending on friction coefficient.

$$M_B = a \cdot F_B \cdot \frac{(D_o - 0,136)}{2} \text{ [Nm]}$$

$$F_B = F_C \cdot 2 \cdot \mu \text{ [N]}$$

$$F_C = A \cdot P \cdot 10 \text{ [N]}$$

CALCULATION FUNDAMENTALS

DUAL-ACTION

Weight of caliper without bracket:	Approx. 850 kg
Overall dimensions:	572 x 318 x 278 mm
Pad width:	138 mm
Pad area:(organic)	58,500 mm ² (*)
Max. wear of pad:(organic)	7 mm (*) "(=14 mm thick)"
Nominal coefficient of friction:	$\mu = 0.4$
Total piston area - each caliper half:	$A = 339,3 \text{ cm}^2$
Total piston area - each caliper:	678,6 cm ²
Volume for each caliper at 1 mm stroke:	67,8 cm ³
Volume for each caliper at 3 mm stroke:	203,5 cm ³
Actuating time (guide value for calculation):	0.8 sec
Pressure connection/port:	1/4" BSP
Drain connection port:	1/4" BSP
Max. operating pressure Pmax	20.5 MPa
Min. operating pressure Pmin	9.0 MPa
Recommended pipe size:	10 mm

Operating temperature range - general from -20°C to +70°C

Operating temperature range - wind turbine from -40°C to +60°C

(For temperatures outside this range contact Svendborg Brakes)

(*) On each brake pad.

Disc Brake: YSAA 60

Specification

Name: DEB-0060-001- MAR
Date: 10.09.2012
Revision: -

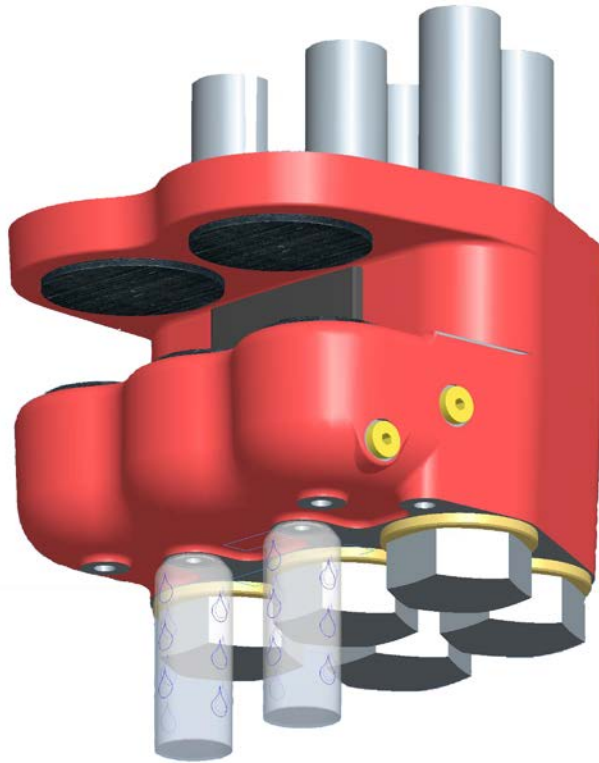

TECHNICAL DATA AND CALCULATION FUNDAMENTALS

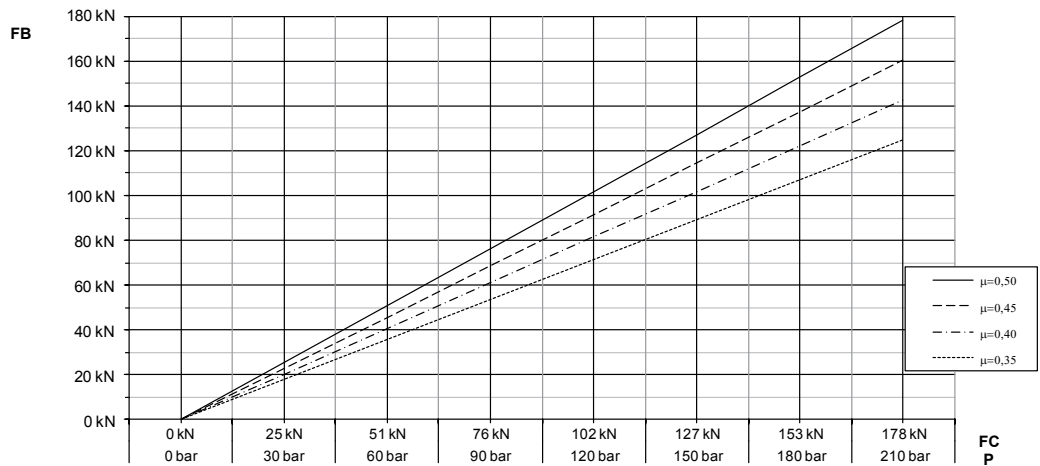

Disc Brake: YSAA 60

Specification

BRAKING TORQUE

The braking torque M_B is calculated from following formula where:

a is the number of brakes acting on the disc

F_B is the braking force according to table above [N]

D_o is the brake disc outer diameter [m]

F_C is the clamping force [N]

A [cm²], P [bar] and μ see values below

The actual braking torque may vary depending on friction coefficient.

$$M_B = a \cdot F_B \cdot \frac{(D_o - 0,102)}{2} \text{ [Nm]}$$

$$F_B = F_C \cdot 2 \cdot \mu \text{ [N]}$$

$$F_C = A \cdot P \cdot 10 \text{ [N]}$$

CALCULATION FUNDAMENTALS

Weight of caliper without bracket incl. pads:	Approx. 51 kg
Overall dimensions:	171 x 265 x 278 mm
Pad diameter:	3xØ 63 mm + 2xØ 93 mm
Pad area:	9,352 mm ² + 13,586 mm ²
Max. wear of Slide/brake material:	TBD
Nominal coefficient of friction:	$\mu = 0.4$
Total piston area - each caliper:	85 cm ²
Volume for each caliper at 1 mm stroke:	8,5 cm ³
Actuating time (guide value for calculation):	0.4 sec
Pressure connection/port:	1/4" BSP
Drain connection port:	1/8" BSP
Max. operating pressure:	200 bar
Recommended pipe size:	8-10 mm

Operating temperature range - general from -40°C to +70°C

Operating temperature range - wind turbine from -40°C to +60°C

(For temperatures outside this range contact Svendborg Brakes)



SVENDBORG NEW BRAKES

Svendborg Brakes is the global market leader in intelligent braking solutions. This is why.

Disc Brake: BSFH D500 (DOUBLE PISTON) DUALspring

Specification

Name: DEB-0500-029-DS-MAR

Date: 20.05.2013

Revision: -



TECHNICAL DATA AND CALCULATION FUNDAMENTALS

CALIPER TYPE	CLAMPING FORCE ¹⁾ [N]		BRAKING FORCE ²⁾ [N]	LOSS OF FORCE PER 1MM [%]	OPERATING PRESSURE ³⁾ MPa	BALANCING PRESSURE ¹⁾ MIN MPa	PAD SURFACE PRESSURE ⁵⁾ [N/mm ²]
	MIN	MAX					
BSFH D524	240,000	260,000	192,000	8.0	12.0	8.3	2.4
BSFH D528	280,000	306,000	224,000	7.0	14.0	9.7	2.8
BSFH D530	300,000	328,000	240,000	6.0	14.5	10.3	3.0
BSFH D532	320,000	350,000	256,000	6.0	15.0	11.0	3.2
BSFH D540	400,000	436,000	320,000	10.0	19.0	13.8	4.0

¹⁾ All figures are based on 1 mm air gap (Total) and 2 spring packs

²⁾ Braking force is based on a min clamping force, nominal coefficient of friction $\mu = 0.4$ and 2 brake surfaces.

³⁾ The piston travel at which the pressure limits is measured - the nominal pressure limits is identical to balancing pressure values

⁵⁾ Pad pressure for organic pads respectively (based on max. clamping force)

Disc Brake: BSFH D500 (DOUBLE PISTON) DUALspring

Specification

BRAKING TORQUE

The braking torque M_B is calculated from following formula where:

a is the number of brakes acting on the disc

F_B is the braking force according to table above [N] or calculated from formula

D_o is the brake disc outer diameter [m]

The actual braking torque may vary depending on adjustment of brake and friction coefficient.

$$M_B = a \cdot F_B \cdot \frac{(D_o - 0,2)}{2} \text{ [Nm]}$$

$$F_B = F_C \cdot 2 \cdot \mu$$

CALCULATION FUNDAMENTALS

DUALSPRING

Weight of caliper without bracket:	Approx. 780 kg
Overall dimensions without base plate:	698 x 530 x 533 (+C) mm
Pad width:	200 mm
Pad area: (organic)	110,000 mm ² (*)
Max. wear of pad: (organic)	10 mm (*)
Nominal coefficient of friction:	$\mu = 0.4$
Total piston area - each caliper half:	$2 \times 145 \text{ cm}^2 = 290 \text{ cm}^2$
Total piston area - each caliper:	$4 \times 145 \text{ cm}^2 = 580 \text{ cm}^2$
Volume for each caliper at 1 mm stroke:	60 cm ³
Volume for each caliper at 3 mm stroke:	180 cm ³
Actuating time (guide value for calculation):	0.4sec
Pressure connection/P-port:	G3/8, ISO 288
Air breathing connection/A-port:	G3/8, ISO 288
Drain connection/L-port:	G1/4, ISO 288
Recommended pipe size:	16/12 mm
Operating temperature range - general	from -20°C to +70°C

(For temperatures outside this range contact Svendborg Brakes)

(C = Brake disc thickness)

(*) On each brake pad.

Disc Brake: BSFH D500 (DOUBLE PISTON) MONOspring

Specification

Name: DEB-0500-029-MS-MAR

Date: 20.05.2013

Revision: -



TECHNICAL DATA AND CALCULATION FUNDAMENTALS

CALIPER TYPE	CLAMPING FORCE ¹⁾ [N]		BRAKING FORCE ²⁾ [N]	LOSS OF FORCE PER 1MM [%]	OPERATING PRESSURE ³⁾ MPa	BALANCING PRESSURE ¹⁾ MIN MPa	PAD SURFACE PRESSURE ⁵⁾ [N/mm ²]
	MIN	MAX					
BSFH D524	240,000	260,000	192,000	8.0	12.0	8.3	2.4
BSFH D528	280,000	306,000	224,000	7.0	14.0	9.7	2.8
BSFH D530	300,000	328,000	240,000	6.0	14.5	10.3	3.0
BSFH D532	320,000	350,000	256,000	6.0	15.0	11.0	3.2
BSFH D540	400,000	436,000	320,000	10.0	19.0	13.8	4.0

¹⁾ All figures are based on 1 mm air gap (Total) and 2 spring packs

²⁾ Braking force is based on a min clamping force, nominal coefficient of friction $\mu = 0.4$ and 2 brake surfaces.

³⁾ The piston travel at which the pressure limits is measured - the nominal pressure limits is identical to balancing pressure values

⁵⁾ Pad pressure for organic pads respectively (based on max. clamping force)

Disc Brake: **BSFH D500 (DOUBLE PISTON) MONOspring**

Specification

BRAKING TORQUE

The braking torque M_B is calculated from following formula where:

a is the number of brakes acting on the disc

F_B is the braking force according to table above [N] or calculated from formula

D_o is the brake disc outer diameter [m]

The actual braking torque may vary depending on adjustment of brake and friction coefficient.

$$M_B = a \cdot F_B \cdot \frac{(D_o - 0,2)}{2} \text{ [Nm]}$$

$$F_B = F_C \cdot 2 \cdot \mu$$

CALCULATION FUNDAMENTALS

MONOSPRING

Weight of caliper without bracket:	Approx. 910 - 1100 kg
Overall dimensions without base plate:	698 x 530 x 351 (+C) mm
Pad width:	200 mm
Pad area: (organic)	110,000 mm ² (*)
Max. wear of pad: (organic)	5 mm (*)
Nominal coefficient of friction:	$\mu = 0.4$
Total piston area - each caliper half:	$2 \times 145 \text{ cm}^2 = 290 \text{ cm}^2$
Total piston area - each caliper:	$2 \times 145 \text{ cm}^2 = 290 \text{ cm}^2$
Volume for each caliper at 1 mm stroke:	30 cm ³
Volume for each caliper at 3 mm stroke:	90 cm ³
Actuating time (guide value for calculation):	0.4sec
Pressure connection/P-port:	G3/8, ISO 288
Air breathing connection/A-port:	G3/8, ISO 288
Drain connection/L-port:	G1/4, ISO 288
Recommended pipe size:	16/12 mm
Operating temperature range - general	from -20°C to +70°C

(For temperatures outside this range contact Svendborg Brakes)

(C = Brake disc thickness)

(*) On each brake pad.

Disc Brake: BSAH D500 (DOUBLE PISTON) DUAL-ACTION

Specification

Name: DEB-0500-030-DA-MAR
Date: 20.05.2013
Revision: -



TECHNICAL DATA AND CALCULATION FUNDAMENTALS

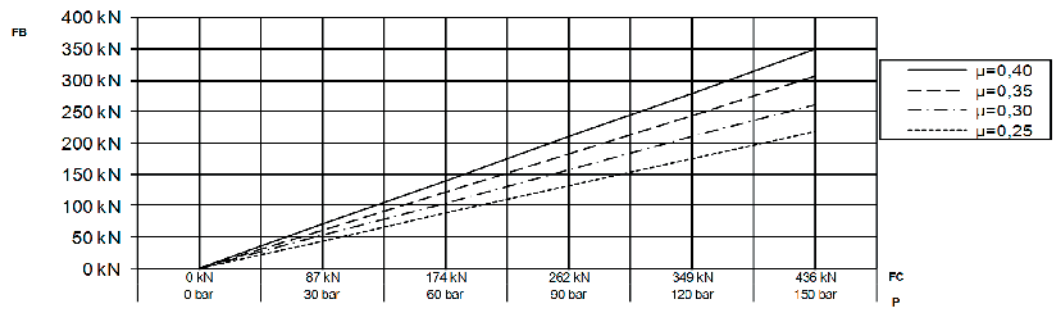

Valid for $P_r = 0$

Disc Brake: BSAH D500 (DOUBLE PISTON) DUAL-ACTION

Specification

BRAKING TORQUE

The braking torque M_B is calculated from following formula where:

a is the number of brakes acting on the disc

F_B is the braking force [N]

D_O is the brake disc outer diameter [m]

F_C is the clamping force [N]

F_r is the piston retraction force [N]

A is the active piston area[cm²]

A_r is the retraction piston area[cm²]

P is the hydraulic pressure[bar]

P_r is the hydraulic retraction pressure[bar]

μ is the coefficient of friction - see values below

The actual braking torque may vary depending on adjustment of brake and friction coefficient.

$$M_B = a \cdot F_B \cdot \frac{(D_O - 0,2)}{2} \text{ [Nm]}$$

$$F_B = (F_C - F_r) \cdot 2 \cdot \mu \text{ [N]}$$

(valid for $F_C > F_r$)

$$F_C = A \cdot P \cdot 10 \text{ [N]}$$

$$F_r = A_r \cdot P_r \cdot 10 \text{ [N]}$$

CALCULATION FUNDAMENTALS

Weight of caliper without bracket:

Overall dimensions excl. base plate:

Pad width:

Pad area:(organic)

Max. wear of pad:(organic)

Nominal coefficient of friction:

Total piston area - each caliper half "A" (active braking):

Total piston area - each caliper "A" (active braking):

Total piston area - each caliper half "A" (retraction):

Total piston area - each caliper "A" (retractio):

Volume for each caliper at 1 mm stroke (active braking):

Volume for each caliper at 3 mm stroke (active braking):

Volume for each caliper at 1 mm stroke (retraction):

Volume for each caliper at 3 mm stroke (retraction):

Actuating time (guide value for calculation):

Active pressure connection size (A-port):

Retraction connection size (P-port):

Drain connection size (L-port):

Max. operating pressure Pmax

Recommended pipe size:

Operating temperature range - general

DUAL-ACTION

Approx. 780 kg

698 x 530 x 533 (+C) mm

200 mm

110,000 mm² (*)

8 mm (*)

$\mu = 0.4$

2 x 145 cm² = 290 cm²

4 x 145 cm² = 580 cm²

2 x 145 cm² = 290 cm²

4 x 145 cm² = 580 cm²

60 cm³

180 cm³

60 cm³

180 cm³

0.4 sec

G3/8, ISO 228

G3/8, ISO 228

G1/4, ISO 228

15.0 MPa (150 bar)

16/12 mm

from -20°C to +70°C

(For temperatures outside this range contact Svendborg Brakes)

(C= Brake disc thickness)

(*) On each brake pad.

Disc Brake: BSAH D500 (DOUBLE PISTON) MONO-ACTION

Specification

Name: DEB-0500-030-MA-MAR

Date: 20.05.2013

Revision: -



TECHNICAL DATA AND CALCULATION FUNDAMENTALS

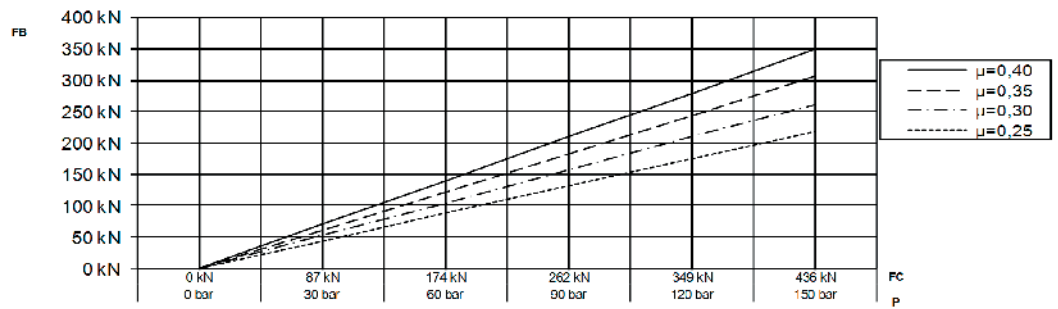

Valid for $P_r = 0$

Disc Brake: BSAH D500 (DOUBLE PISTON) MONO-ACTION

Specification

BRAKING TORQUE

The braking torque M_B is calculated from following formula where:

a is the number of brakes acting on the disc

F_B is the braking force [N]

D_O is the brake disc outer diameter [m]

F_C is the clamping force [N]

F_r is the piston retraction force [N]

A is the active piston area[cm²]

A_r is the retraction piston area[cm²]

P is the hydraulic pressure[bar]

P_r is the hydraulic retraction pressure[bar]

μ is the coefficient of friction - see values below

The actual braking torque may vary depending on adjustment of brake and friction coefficient.

$$M_B = a \cdot F_B \cdot \frac{(D_O - 0,2)}{2} \text{ [Nm]}$$

$$F_B = (F_C - F_r) \cdot 2 \cdot \mu \text{ [N]}$$

(valid for $F_C > F_r$)

$$F_C = A \cdot P \cdot 10 \text{ [N]}$$

$$F_r = A_r \cdot P_r \cdot 10 \text{ [N]}$$

CALCULATION FUNDAMENTALS

Weight of caliper without bracket:

Overall dimensions excl. base plate:

Pad width:

Pad area:(organic)

Max. wear of pad:(organic)

Nominal coefficient of friction:

Total piston area - each caliper half "A" (active braking):

Total piston area - each caliper "A" (active braking):

Total piston area - each caliper half "A" (retraction):

Total piston area - each caliper "A" (retractio):

Volume for each caliper at 1 mm stroke (active braking):

Volume for each caliper at 3 mm stroke (active braking):

Volume for each caliper at 1 mm stroke (retraction):

Volume for each caliper at 3 mm stroke (retraction):

Actuating time (guide value for calculation):

Active pressure connection size (A-port):

Retraction connection size (P-port):

Drain connection size (L-port):

Max. operating pressure Pmax

Recommended pipe size:

Operating temperature range - general

MONO-ACTION

Approx. 910-1000 kg

698 x 530 x 351 (+C) mm

200 mm

110,000 mm² (*)

6 mm (*)

$\mu = 0.4$

$2 \times 145 \text{ cm}^2 = 290 \text{ cm}^2$

$2 \times 145 \text{ cm}^2 = 290 \text{ cm}^2$

$2 \times 145 \text{ cm}^2 = 290 \text{ cm}^2$

$2 \times 145 \text{ cm}^2 = 290 \text{ cm}^2$

30 cm³

90 cm³

30 cm³

90 cm³

0.4 sec

G3/8, ISO 228

G3/8, ISO 228

G1/4, ISO 228

15.0 MPa (150 bar)

16/12 mm

from -20°C to +70°C

(For temperatures outside this range contact Svendborg Brakes)

(C= Brake disc thickness)

(*) On each brake pad.



SVENDBORG SPECIAL RANGE

Svendborg Brakes is the global market leader in intelligent braking solutions.

Electro-Hydraulic Brake: DRUM Brake 18735

Specification

Name: 18735-MAR
Date: 25.05.2012
Revision: A

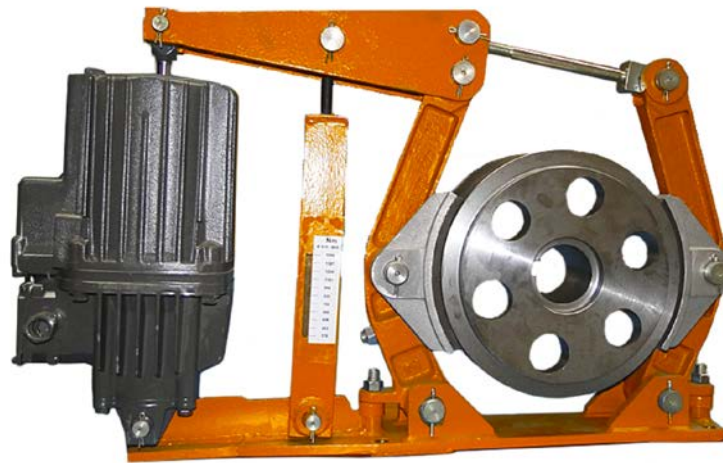

TECHNICAL DATA AND CALCULATION FUNDAMENTALS

Svendborg Brakes – drum brakes are built in their details and connecting dimensions according to DIN 15435.

All pin joints are furnished with maintenance-free, self-lubricating bearing bushes.

The braking torques are stepless adjustable with a screw and will be read directly on spring tube.

Svendborg Brakes – drum brakes are delivered with aluminium brake shoes and sticked-on brake linings, if not other requested.

Electro-Hydraulic Brake: DRUM Brake 18735

Specification

Designation of a drum brake \varnothing 400 for brake lifter Ed 80/6:
SB – Drum brake 400-80/6 NO 18735

DRAWINGS

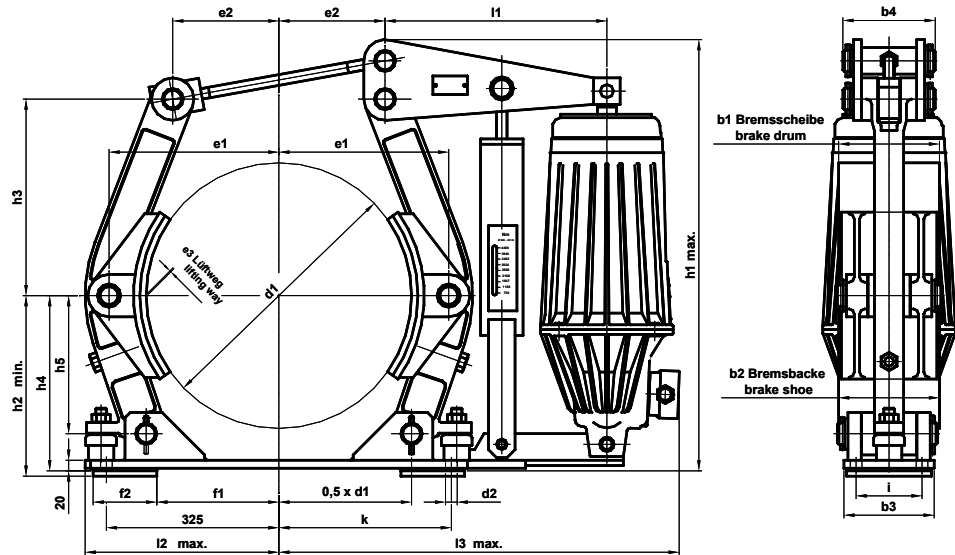

CALCULATION FUNDAMENTALS

Abmessungen - Dimensions (mm)																				$M_{B \max}$		lifter	unit weight												
d_1	b_1	b_2	b_3	b_4	d_2	e_1	e_2	e_3	f_1	f_2	h_1	h_2	h_3	h_4	h_5	h_6	i	k	l_1	l_2	l_3			$\mu=0,4$	Ed	kg									
200	75	70	80	85	14	140	100	1,1	65	100	396	160	165	155	110	15	55	145	240	175	460	230	23/5	20											
											480																				300	30/5			
250	95	90	100	100	18	170	125	1,3	95	100	466	190	200	185	135	17	65	180	260	205	505	240	23/5	30											
											485																				502	30/5			
315	118	110	110	125	18	212	140	1,2	135	100	566											557	420	30/5	40										
								1,5			570	230	250	225	170	17	80	220	300	248	597	620	50/6												
											585																				1060	80/6			
400	150	140	140	165	22	260	160	1,5	170	120	676											672	1310	80/6	80										
											795	280	305	270	205	20	100	270	355	300	655	1890	121/6												
																																3300	201/6		
500	190	180	170	200	22	320	200	1,4	230	120	812	340	370	330	260	20	130	325	418	365	775	1810	80/6	115											
								2,8			920																				2650	121/6			
																																		4550	201/6
630	236	225	220	240	27	390	255	1,5	280	150	977	420	440	410	325	25	170	400	475	445	870	3200	121/6	200											
								3																									5500	201/6	
710	265	255	240	270	27	440	285	1,5	335	150	1089	470	490	460	370	25	190	450	505	500	930	5900	201/6	250											
								3																										9500	301/6

1) Settings in accordance with the optimal nominal running parameters of the thruster. Other settings on request.

Application with other lifting devices by order agreed.

SB – Brake shoes see NO 18800

SB – Brake linings see NO 18812

Electro-Hydraulic Brake: LIFTING Devices 18830

Specification

Name: 18830-MAR
Date: 24.05.2012
Revision: A

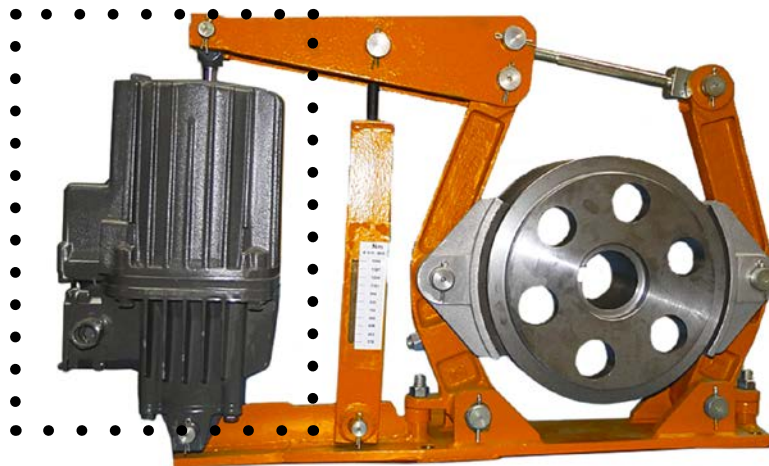

Designation of an electro-hydraulic brake lifting device with three phase alternating current design (Ed) with a nominal lifting force of 220 N, a stroke B of 50 mm, with countersunk valve S for operating voltage 3 AC 50 Hz 500 V:

TECHNICAL DATA AND CALCULATION FUNDAMENTALS

Nenngröße size Ed	Abmessungen - Dimensions (mm)																Stück- gewicht unit weight kg							
	A	B	C	D	E ^{+0,1}	F	G	H ^{+0,25 +0,15}	I	K	L	M	N	O	P	a		b	c	d	e	z		
23/5	286	50	26	12	12	20	16	20					40	200	16		20							10
30/5	370		34	15	16	25		18		160		80		197		100		55	85	75	15		14	
50/6	435	60															22						23	
50/12	515	120	36	18	20	30	20	23	-	195	-	120	60	254	22	-	-	-	-	-	-	-	26	
80/6	450	60														100	22	55	85	75	15	24		
80/12	530	120														-	-	-	-	-	-	-	27	
121/6	645	60														147	35	80	130	120	20		39	
121/12	705	120														-	-	-	-	-	-			
201/6	645	60	38	25	25	40	25	35	117	240	112	90	40	260	25	147	35	80	130	120	20			
201/12	705	120														-	-	-	-	-	-			
301/6	645	60														147	35	80	130	120	20		40	
301/12	705	120														-	-	-	-	-	-			

Electro-Hydraulic Brake: LIFTING Devices 18830

Specification

DRAWINGS

Brake lifting device Ed 23/5-S 50 Hz 500 V-NO 18830

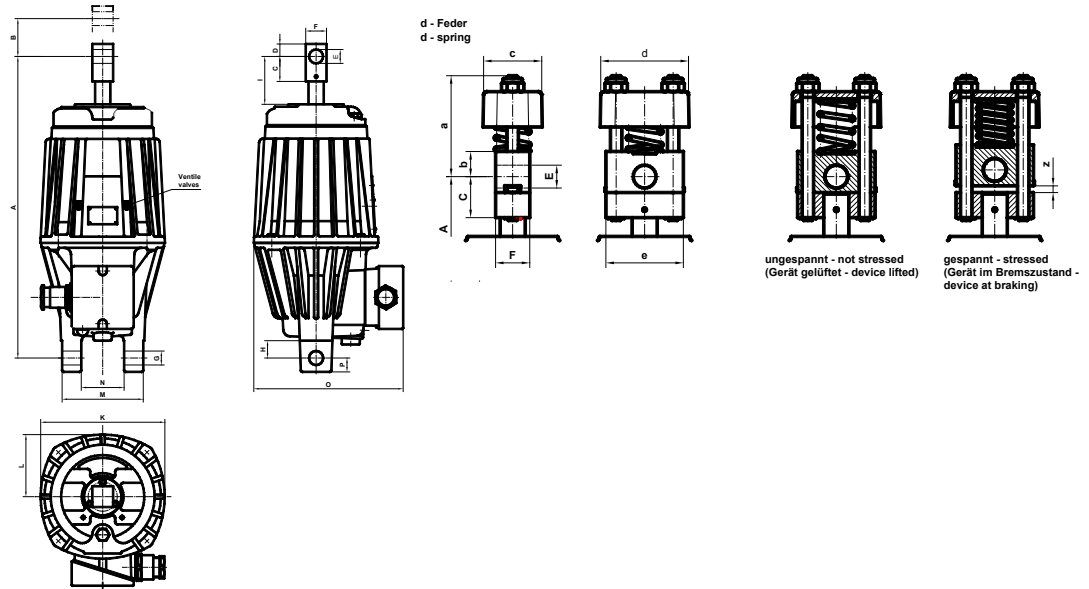

CALCULATION FUNDAMENTALS

Nenngröße	Hubkraft	Hubweg	Hubarbeit	Bremsfederkraft (c - Feder)	Leistungs- aufnahme
size	stroke power	stroke distance	stroke operating	brake spring power (c - spring)	power input
Ed	N	mm	N/cm	N	W
23/5	220	50	1100	180	165
30/5	300		1500	270	200
50/6	500	60	3000	460	210
50/12		120	6000	-	
80/6	800	60	4800	750	330
80/12		120	9600	-	
121/6	1250	60	7500	120	330
121/12		120	15000	-	
201/6	2000	60	12000	1900	450
201/12		120	24000	-	
301/6	3000	60	18000	2700	550
301/12		120	36000	-	

Electro-Hydraulic Brake: BRAKE Shoes 18800

Specification

Name: 18800-MAR
Date: 24.05.2012
Revision: A



Measuring points for determination of form variation.

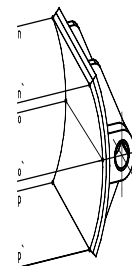
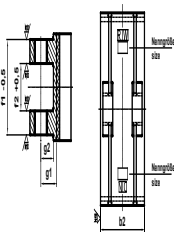
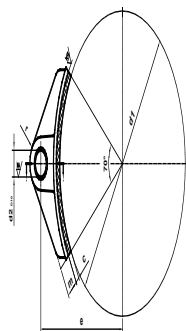

Designation of a brake shoe without rivet holes with stuck on brake lining (form C) for brake drum diameter $d_1 = 500$ mm:
SB – brake shoe C 500 NO 18800 with lining ³⁾

Electro-Hydraulic Brake: BRAKE Shoes 18800

Specification

CALCULATION FUNDAMENTALS

- 1) Admissible deviation of parallelism related to bores d2 and sticking area.
- 2) Admissible form deviation related to friction area between brake lining and brake drum (with tolerance range h11) related to measuring points n, o, p and n', o', p'.
- 3) SB – Brake lining according to NO 18812 respectively by choice of purchaser.

Material: Aluminium – sand-casting

SB – Drum brakes see NO 18735

Nenngröße size	Abmessungen - Dimensions (mm)											Stückgewicht unit weight kg
	d ₁	b ₂	c	d ₂ /r	e	f ₁	f ₂	g ₁	z ¹⁾ Abweichung admissible deviation	g ₂	m _{max.}	
200	70	8	20	140	65	35	32	0,1	24	17	0,15	0,5
250	90	8	25	170	80	40	37		29	22		0,8
315	110	10	30	212	100	50	44,5		34,5	25		1,4
400	140	10	35	260	125	62	50	0,15	40	30	0,2	2,1
500	180	12	40	320	160	80	58		46	33		3,8
630	225	12	45	390	200	100	63	0,2	51	38	0,3	5,5
710	255	15	50	440	224	112	70		56	40		8,2

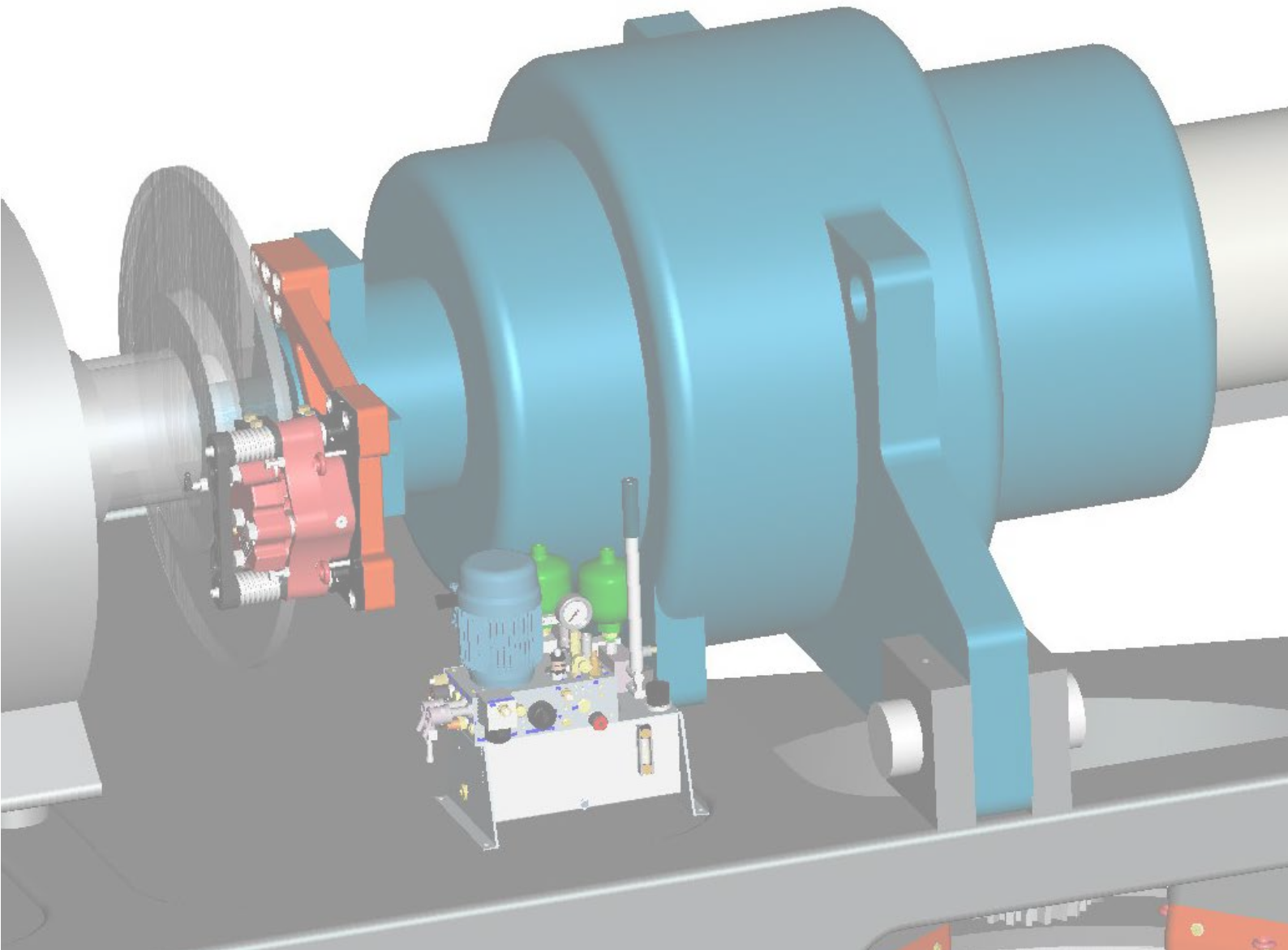

HYDRAULIC WIND RANGE

Svendborg Brakes is the global market leader in intelligent braking solutions. This is why.

Example for a Direct Drive Wind Turbine

Specification

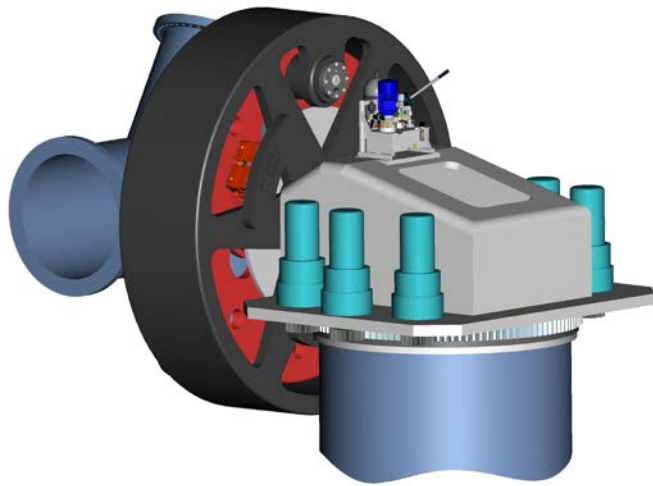

Combined hydraulic power unit
for active rotor brake and rotor
lock control

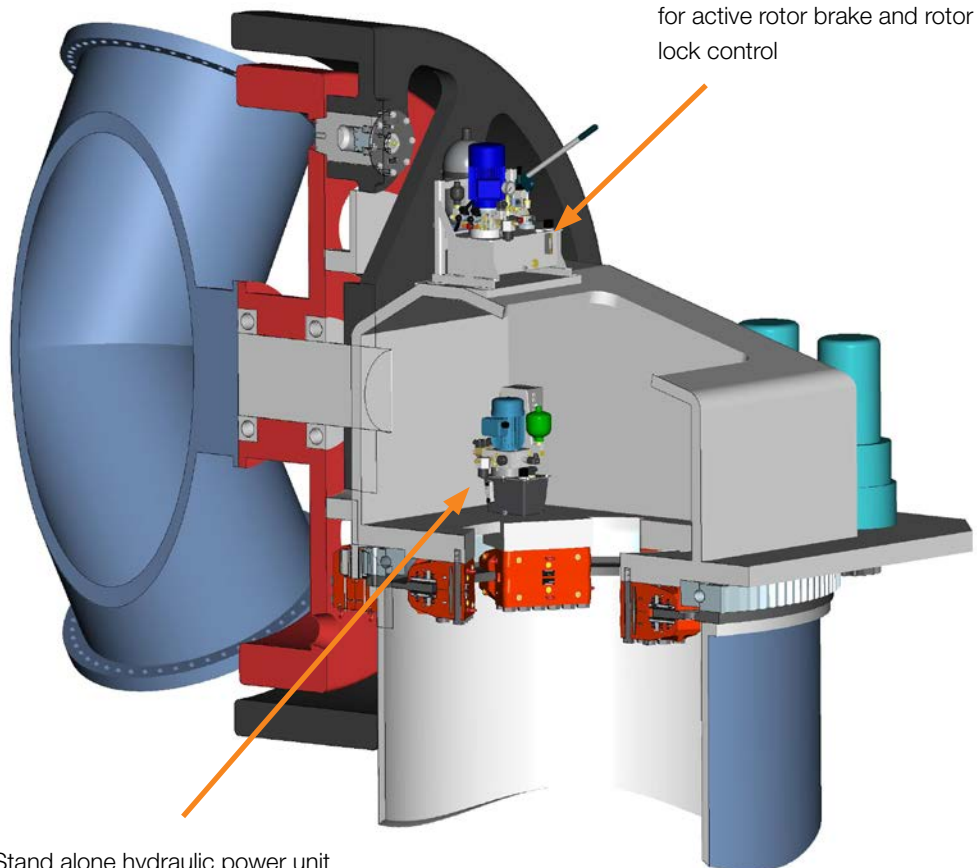

Stand alone hydraulic power unit
for yaw brake control

Example for a Direct Drive Wind Turbine

Specification

SYSTEM CIRCUIT

The electrical motor drives a hydraulic gearpump. The Pump feeds the system accumulator, controlled by a pressure switch or a transmitter. The System pressure can be released manually by shut-off cock or manual override of the valves. A High pressure filter between the pump and the system ensures the cleanliness of the hydraulic system. A Certified pressure control valve ensures pressure relief in case of control failures. Optional transmitter on system accumulator for checking the nitrogen pre-charge.

Combined hydraulic power unit for active rotor brakes and rotor lock control

1010-0124-8XX

GENERAL FEATURES:

- compact and cost efficient design mounted on 20 liter tank
- 2/2 seat valve technology, leak oil free
- sub components from qualified suppliers
- universal manifold
- robust asynchronous 400V/50Hz el. motor
- oil level + temperature control

ROTOR BRAKE CIRCUIT:

- fail safe brake activation or idling function in case of power loss
- 24h / 7 days pressure holding capacity
- delay time according to customer demands
- pressure switch or transmitter for brake status control
- flushing function with filter in return line

OPTIONAL FEATURES:

- UL-approved electrical components
- drip pan
- electrical cabinet
- customer specific electrical plug connection
- cold climate version
- 690 V electrical motor
- 60Hz
- Handpump
- pressure gauge for visual inspection

ROTOR LOCK CIRCUIT:

- adjustable pressure for rotor lock
- 4/3 valve for rotor lock control is protected by additional 2/2 valves
- 24h / 7 days pressure holding capacity
- ‘cylinder holding function’ included

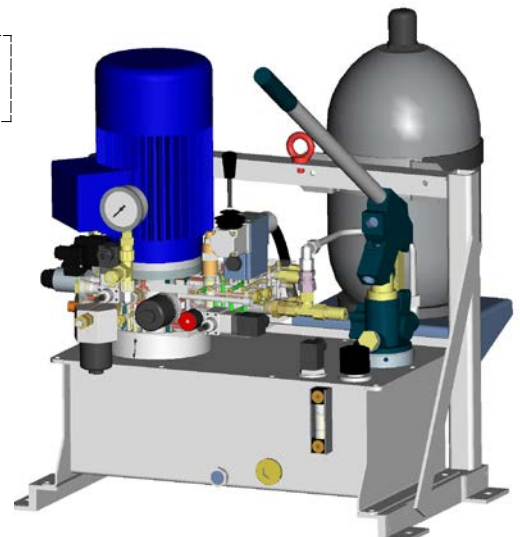
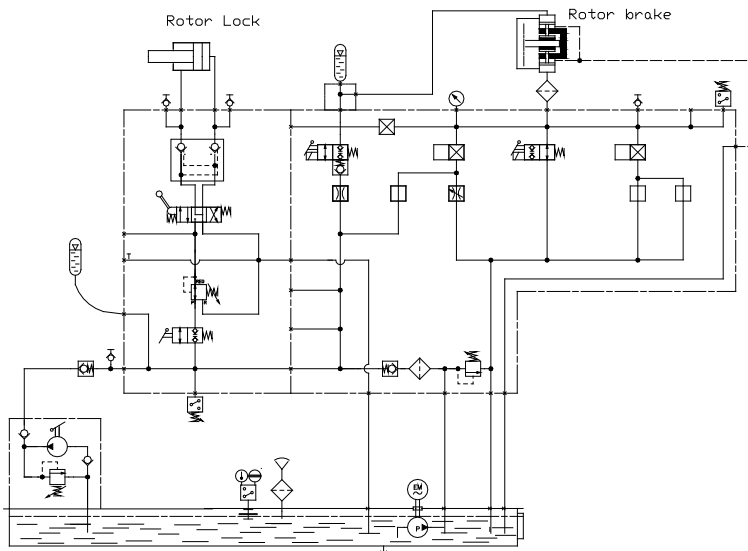

Functions:

Specification

SYSTEM CIRCUIT

The electrical motor drives a hydraulic gearpump. The Pump feeds the system accumulator, controlled by a pressure switch or a transmitter. The System pressure can be released manually by cock or a manual override of the valves. A High pressure filter between the pump and the system ensures cleanliness of the hydraulic system. A Certified pressure control valve ensures pressure relief in case of control failures. Optional transmitter on system accumulator for checking the nitrogen pre-charge.

YAW BRAKE CIRCUIT:

- yaw brakes with 3 pressure levels, i.e.
 -)160 bar for holding function
 -)30 bar for slewing
 -)0 bar for cable loop unwinding operation
- flushing function with filter in return line
- 24h / 7 days pressure holding capacity
- pressure switch or transmitter for brake status control

Stand-alone hydraulic power unit for yaw brakes control

1010-0084-8XX

GENERAL FEATURES:

- compact and cost efficient design mounted on 6 liter tank
- 2/2 seat valve technology, leak oil free
- sub components from qualified suppliers
- universal manifold
- robust asynchronous 400V/50Hz el. motor
- oil level + temperature control

OPTIONAL FEATURES:

- UL-approved electrical components
- drip pan
- electrical cabinet
- customer specific electrical plug connection
- cold climate version
- 690 V el. motor
- 60Hz
- Handpump
- pressure gauge for visual inspection

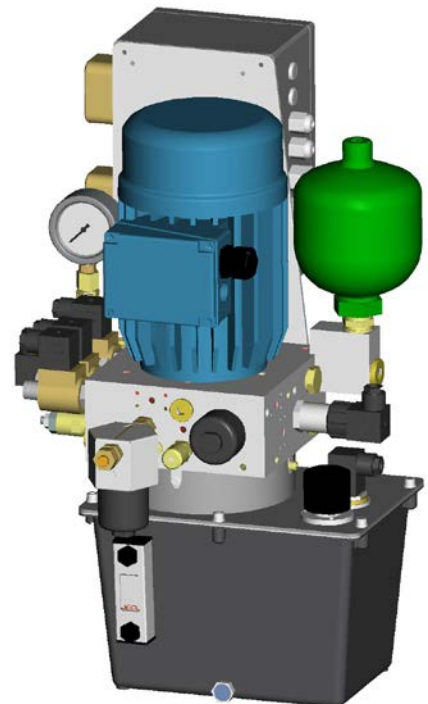
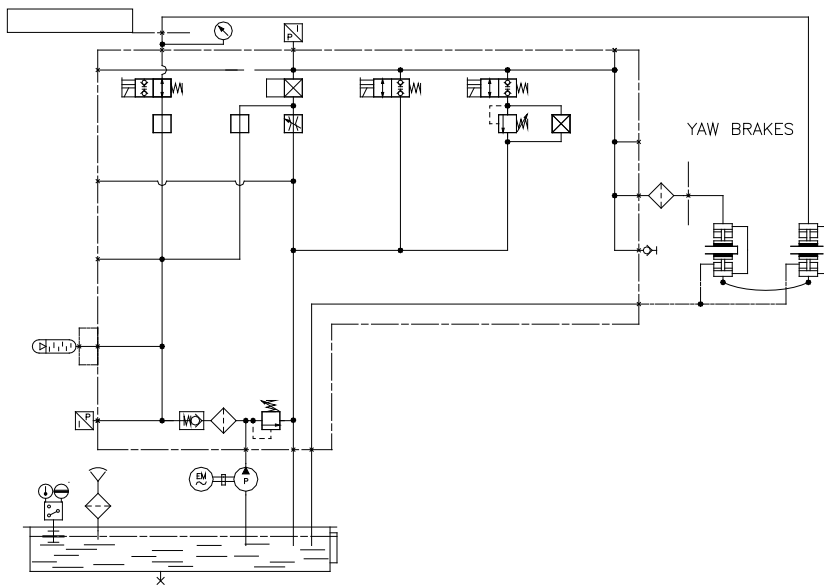

Example for a Direct Drive Wind Turbine

Specification

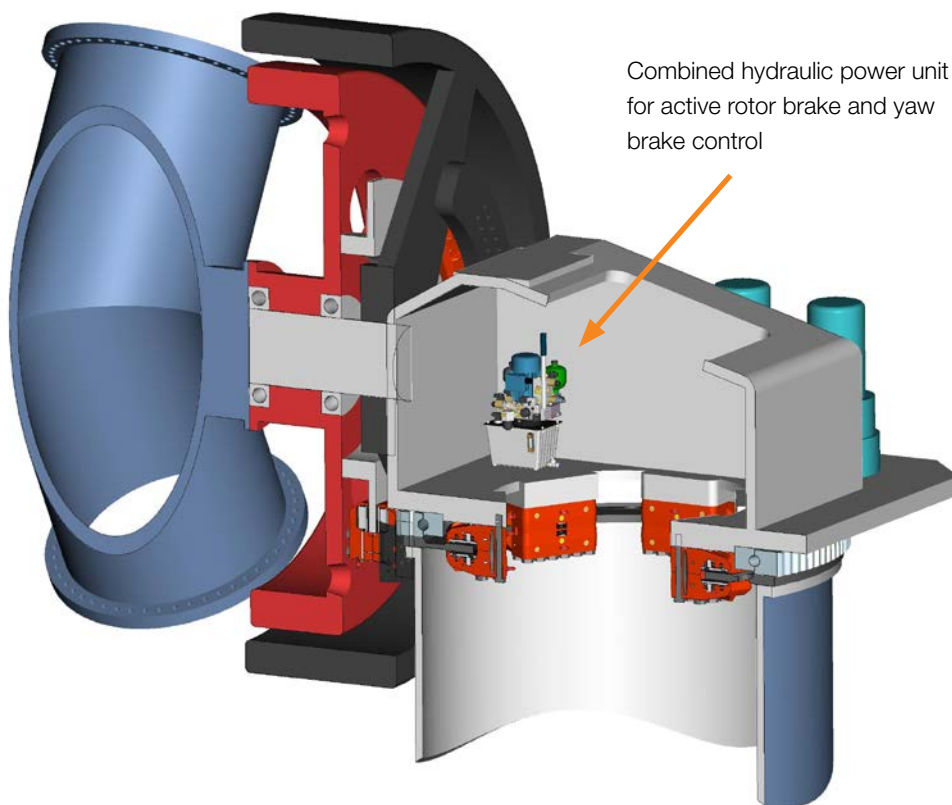
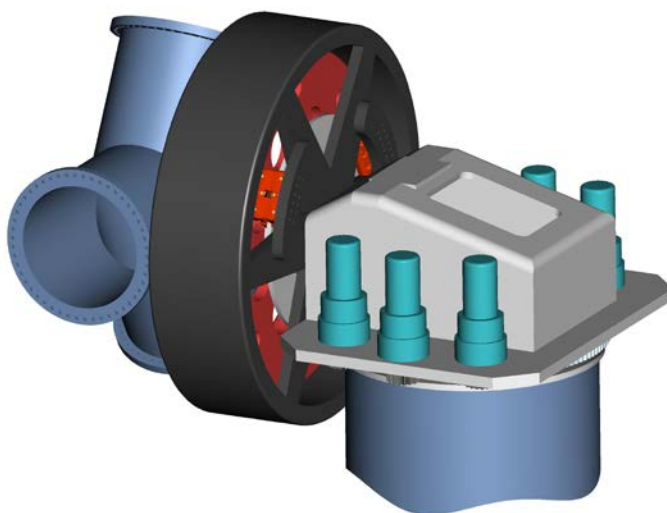

Combined hydraulic power unit
for active rotor brake and yaw
brake control

Example for a Direct Drive Wind Turbine

Specification

SYSTEM CIRCUIT

The electrical motor drives a hydraulic gearpump. The Pump feeds the system accumulator, controlled by a pressure switch or a transmitter. The system pressure can be released manually by shut-off cock or manual override of valves. The high pressure filter between the pump and the system ensures the cleanliness of the hydraulic system. The certified pressure control valve ensures pressure relief in case of control failures. Optional transmitter on system accumulator for checking the nitrogen pre-charge.

ROTOR BRAKE CIRCUIT:

- fail safe brake activation or idling function in case of power loss
- 24h / 7 days pressure holding capacity
- pressure switch or transmitter for brake status control

YAW BRAKE CIRCUIT:

- yaw brakes with 3 pressure levels, i.e.
 -)160 bar for holding function
 -)30 bar for yaw operation
 -)0 bar for cable loop unwinding operation
- flushing function with filter in return line
- 24h / 7 days pressure holding capacity
- pressure switch or transmitter for brake status control

Combined hydraulic power unit for active rotor brakes of BSAB series and yaw brake control

1010-0099-8XX

TYPICAL APPLICATION:

- hydraulic Power pack for gearless turbines.

GENERAL FEATURES:

- compact and cost efficient design mounted on 6 liter tank
- 2/2 seat valve technology, leak oil free
- sub components from qualified suppliers
- universal manifold
- robust asynchronous 400V/50Hz el. motor
- oil level + temperature control

OPTIONAL FEATURES:

- UL-approved electrical components
- drip pan
- electrical cabinet
- customer specific electrical plug connection
- cold climate version
- 690 V el. motor
- 60Hz
- Handpump
- Pressure gauge for visual inspection

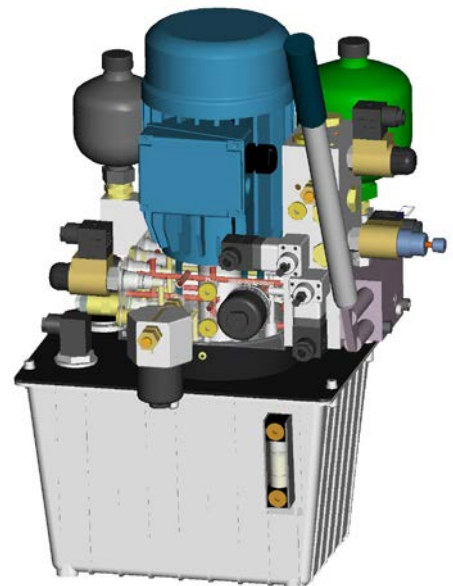
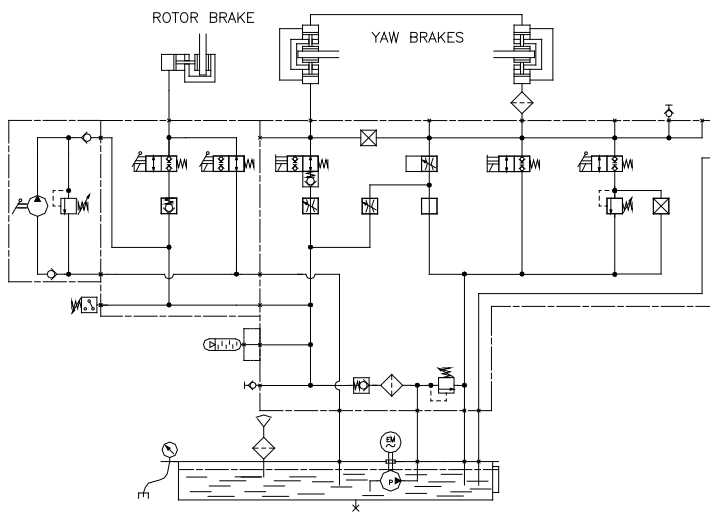

Example for a Direct Drive Wind Turbine

Specification

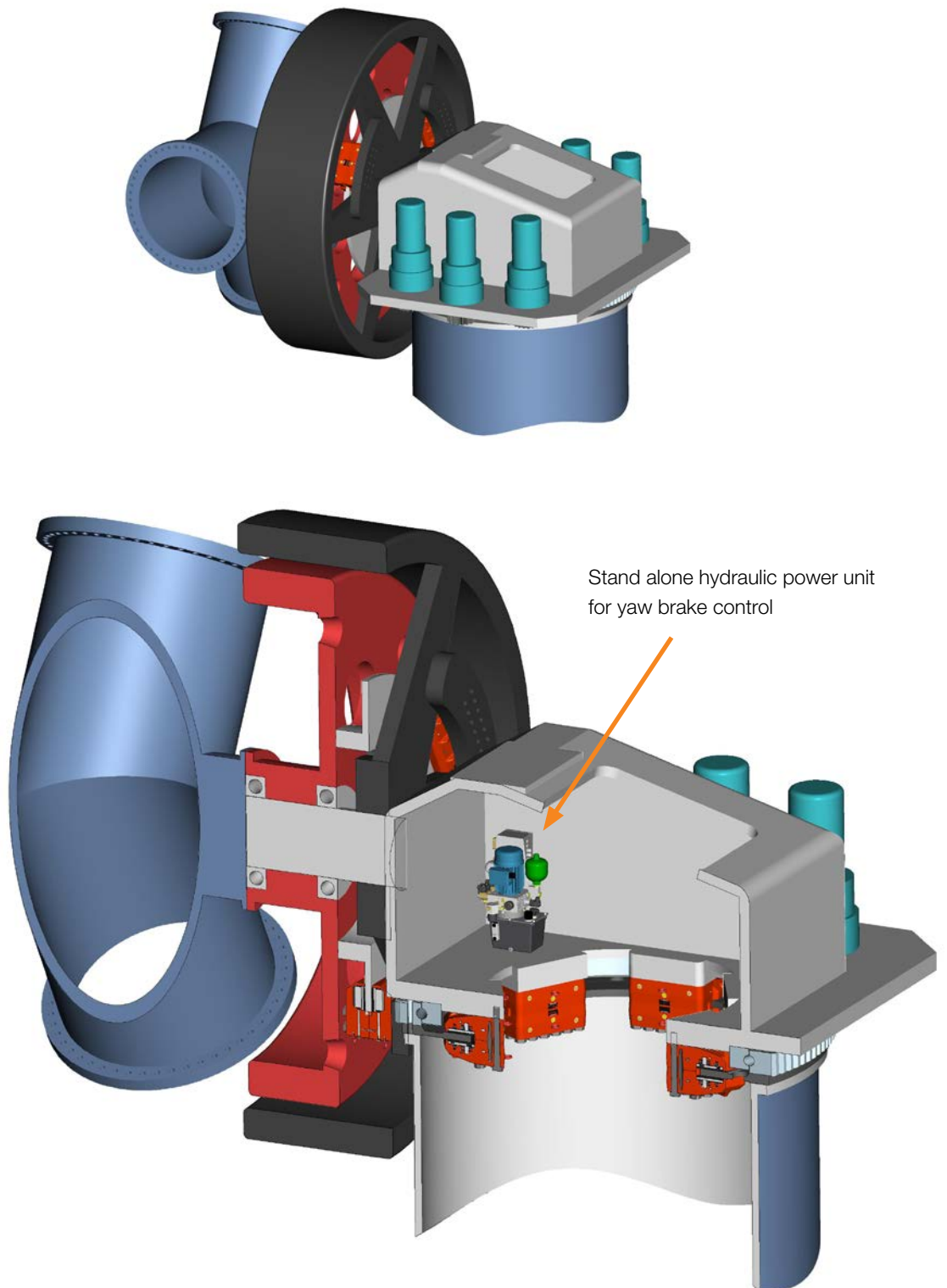

Example for a Direct Drive Wind Turbine

Specification

SYSTEM CIRCUIT

The electrical motor drives a hydraulic gearpump. The pump feeds the system accumulator, controlled by a pressure switch or a transmitter. The system pressure can be released manually by a shut-off cock or by manual override of valves. The high pressure filter between the pump and the system ensures the cleanliness of the hydraulic system. The certified pressure control valve ensures pressure relief in case of control failures. Optional transmitter on the system accumulator for checking the nitrogen pre-charge.

YAW BRAKE CIRCUIT

- yaw brakes with 3 pressure levels, i.e.
 -)160 bar for holding function
 -)30 bar for yaw operation
 -)0 bar for cable loop unwinding operation
- flushing function with filter in return line
- 24h / 7 days pressure holding capacity
- pressure switch or transmitter for brake status control

Stand-alone hydraulic power unit for yaw brakes control

1010-0084-8XX

GENERAL FEATURES:

- compact and cost efficient design mounted on 6 liter tank
- 2/2 seat valve technology, leak oil free
- sub components from qualified suppliers
- universal manifold
- robust asynchronous 400V/50Hz el. motor
- oil level + temperature control

OPTIONAL FEATURES:

- UL-approved electrical components
- drip pan
- electrical cabinet
- customer specific electrical plug connection
- cold climate version
- 690 V el. motor
- 60Hz
- Handpump
- pressure gauge for visual inspection

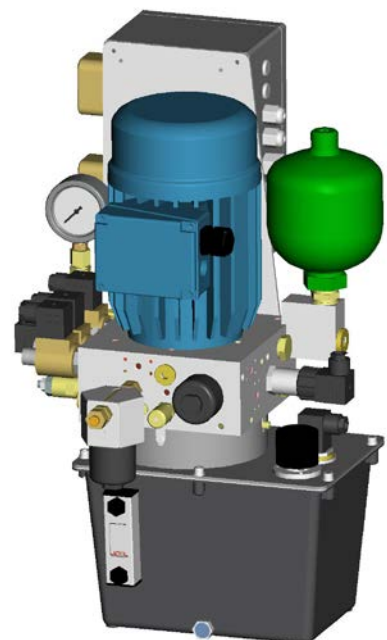
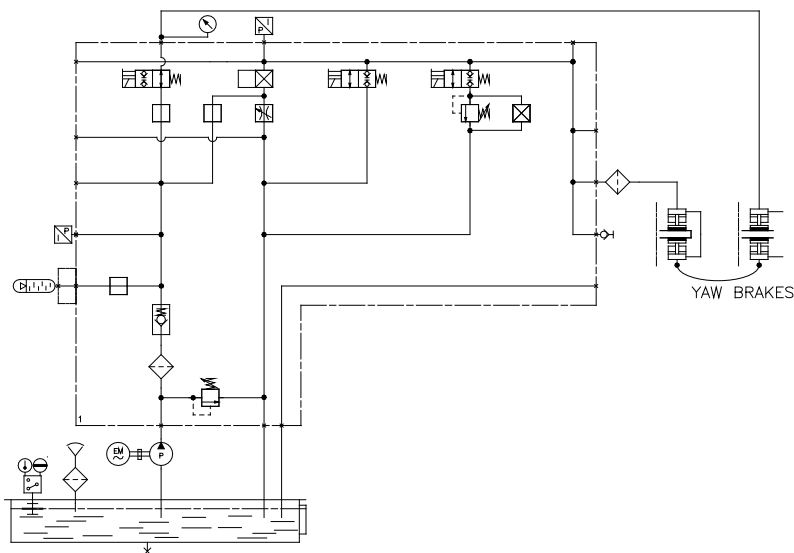

Example for a Conventional Wind Turbine

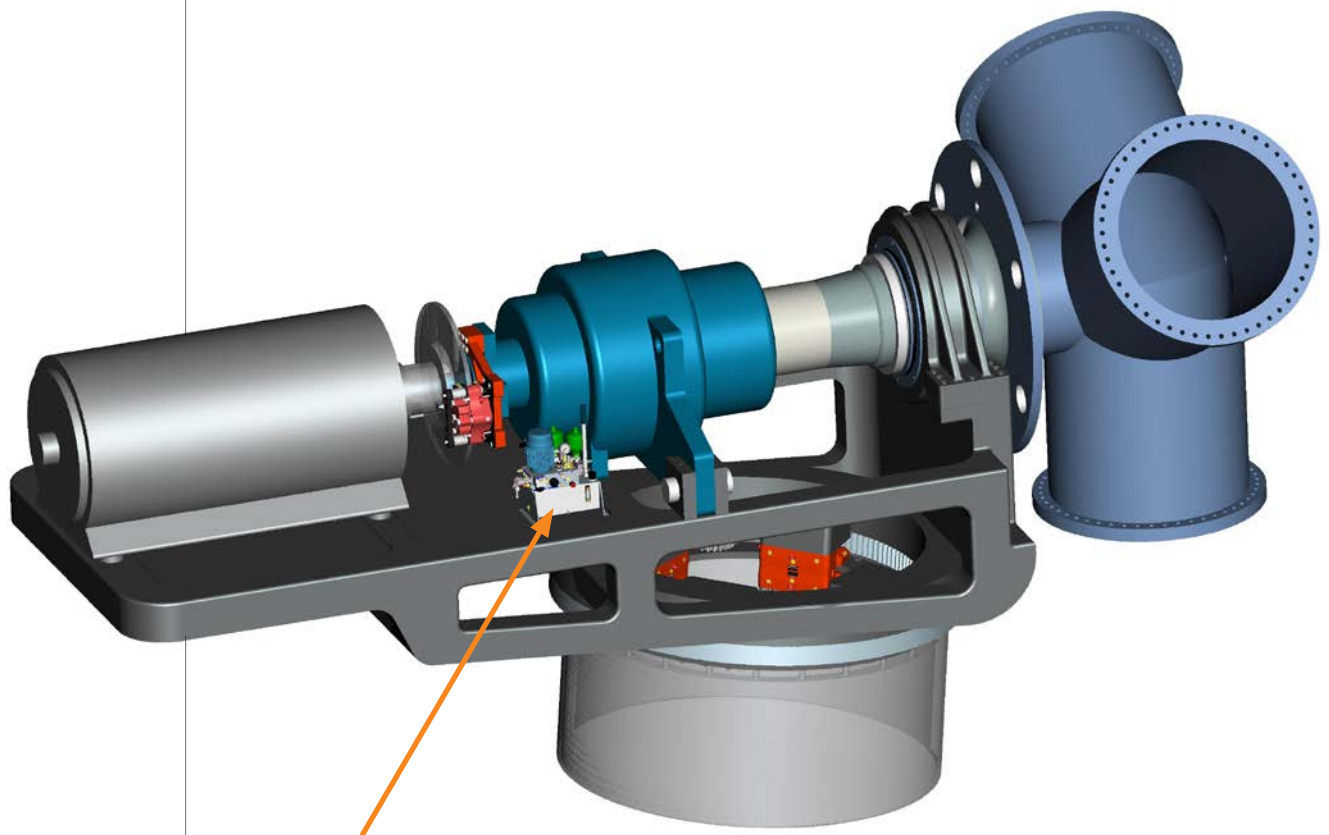

Combined hydraulic power unit for active rotor brake and yaw brake control

VARIANTE:ROLO-EXAMPLE

Example for a Conventional Wind Turbine

Specification

SYSTEM CIRCUIT

The electrical motor drives a hydraulic gearpump. The pump feeds the system accumulator, controlled by a pressure switch or a transmitter. The system pressure can be released manually by a shut-off cock or manual override of valves. The high pressure filter between the pump and the system ensures the cleanliness of hydraulic system. The certified pressure control valve ensures pressure relief in case of control failures. Optional transmitter on system accumulator for checking the nitrogen pre-charge.

ROTOR BRAKE CIRCUIT:

- fail safe brake activation or idling function in case of power loss
- 24h / 7 days pressure holding capacity
- delay time according to customer demands
- pressure switch or transmitter for brake status control

YAW BRAKE CIRCUIT:

- yaw brakes with 3 pressure levels, i.e.
 -)160 bar for holding function
 -)30 bar for yaw operation
 -)0 bar for cable loop unwinding operation
- flushing function with filter in return line
- 24h / 7 days pressure holding capacity
- pressure switch or transmitter for brake status control

Combined hydraulic power unit for active rotor brakes and yaw brake control

1010-0139-8XX

GENERAL FEATURES:

- compact and cost efficient design mounted on 10 liter tank
- 2/2 seat valve technology, leak oil free
- sub components from qualified suppliers
- universal manifold
- robust asynchronous 400V/50Hz el. motor
- oil level + temperature control

OPTIONAL FEATURES:

- UL approved electrical components
- drip pan
- electrical cabinet
- customer specific electrical plug connection
- cold climate version
- 690 V el. motor
- 60Hz
- Handpump
- Pressure gauge for visual inspection

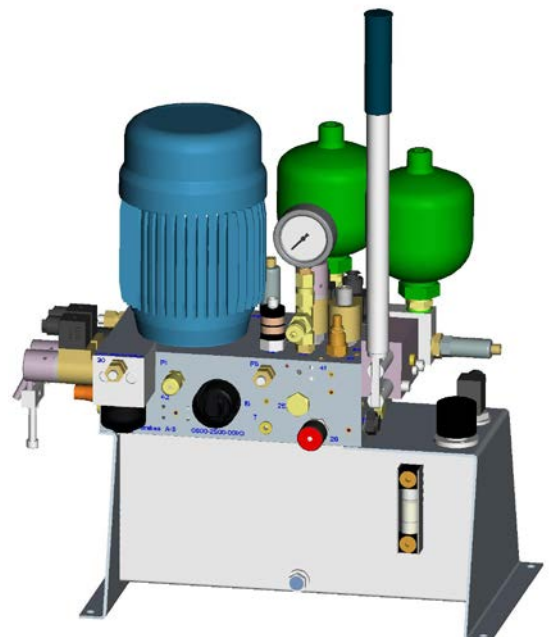
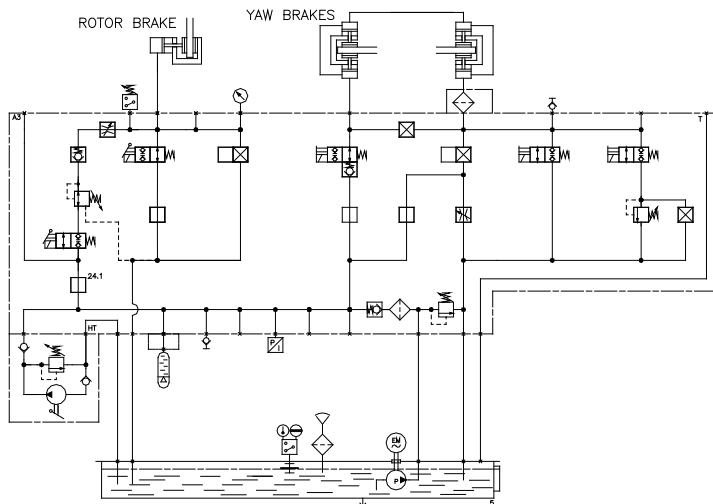

Example for a Conventional Wind Turbine

Specification

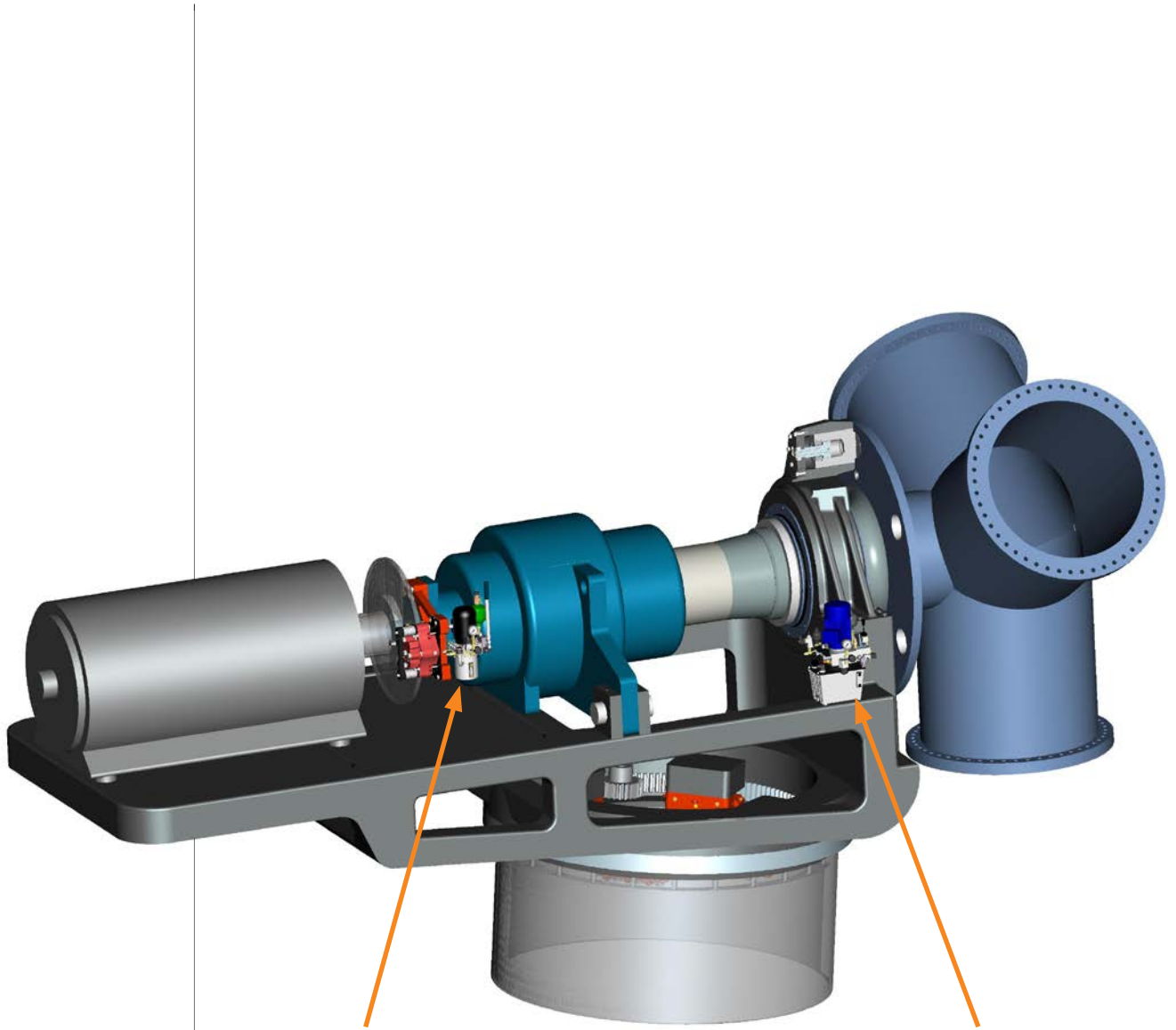

Stand alone hydraulic power unit
for active rotor brake control

Combined hydraulic power unit for
yaw brake and rotor lock control

VARIANTE:ROLO-EXAMPLE

Example for a Conventional Wind Turbine

Specification

SYSTEM CIRCUIT

The electrical motor drives a hydraulic gearpump. The pump feeds the system accumulator, controlled by a pressure switch or a transmitter. The system pressure can be released manually by a shut-off cock or manual override of valves. The high pressure filter between the pump and the system ensures cleanliness of hydraulic system. The certified pressure control valve ensures pressure relief in case of control failures. Optional transmitter on system accumulator for checking the nitrogen pre-charge.

Combined hydraulic power unit for yaw brake and rotor lock control

1010-0124-802

GENERAL FEATURES:

- compact and cost efficient design mounted on 6 liter tank
- 2/2 seat valve technology, leak oil free
- sub components from qualified suppliers
- universal manifold
- robust asynchronous 400V/50Hz el. motor
- oil level + temperature control

ROTOR LOCK CIRCUIT:

- adjustable pressure for rotor lock
- 4/3 valve for rotor lock control is protected by additional 2/2 valves
- 24h / 7 days pressure holding capacity
- 'cylinder holding function' included

OPTIONAL FEATURES:

- UL-approved electrical components
- drip pan
- electrical cabinet
- customer specific electrical plug connection
- cold climate version
- 690 V el. motor
- 60Hz
- handpump
- pressure gauge for visual inspection

YAW BRAKE CIRCUIT:

- yaw brakes with 3 pressure levels, i.e.
 -)160 bar for holding function
 -)30 bar for yaw operation
 -)0 bar for cable loop unwinding operation
- flushing function with filter in return line
- 24h / 7 days pressure holding capacity
- pressure switch or transmitter for brake status control

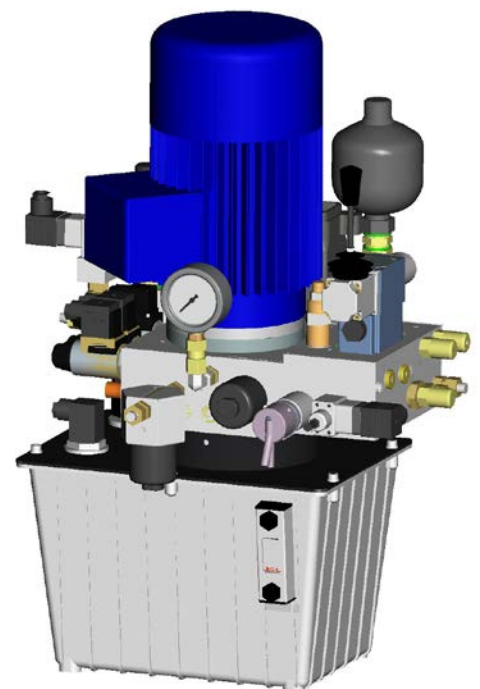
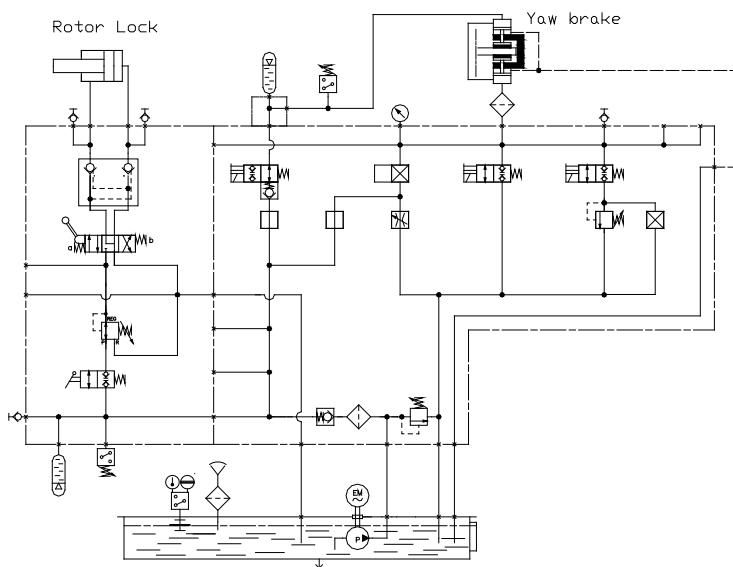

Example for a Conventional Wind Turbine

Specification

SYSTEM CIRCUIT

The electrical motor drives a hydraulic gearpump. The pump feeds the system accumulator, controlled by a pressure switch or a transmitter. The system pressure can be released manually by shut-off cock or manual override of valves. The high pressure filter between the pump and the system ensures the cleanliness of the hydraulic system. The certified pressure control valve ensures pressure relief in case of control failures. Optional transmitter on system accumulator for checking the nitrogen pre-charge.

ROTOR BRAKE CIRCUIT

- fail safe brake activation or idling function in case of power loss
- 2 modes of brake activation, with and without delay
- 2 step braking torque, i.e. reduced torque for braking, full torque for holding function
- 24h / 7 days pressure holding capacity
- delay time according to customer demands
- pressure switch or transmitter for brake status control

Stand-alone hydraulic power unit for active rotor brakes (on hss)

1010-006X-8XX

GENERAL FEATURES:

- compact and cost efficient design mounted on 3 liter tank
- 2/2 seat valve technology, leak oil free
- sub components from qualified suppliers
- universal manifold
- robust asynchronous 400V/50Hz el. motor
- oil level + temperature control

OPTIONAL FEATURES:

- UL-approved electrical components
- drip pan
- electrical cabinet
- customer specific electrical plug connection
- cold climate version
- 690 V el. motor
- 60Hz
- Handpump
- pressure gauge for visual inspection

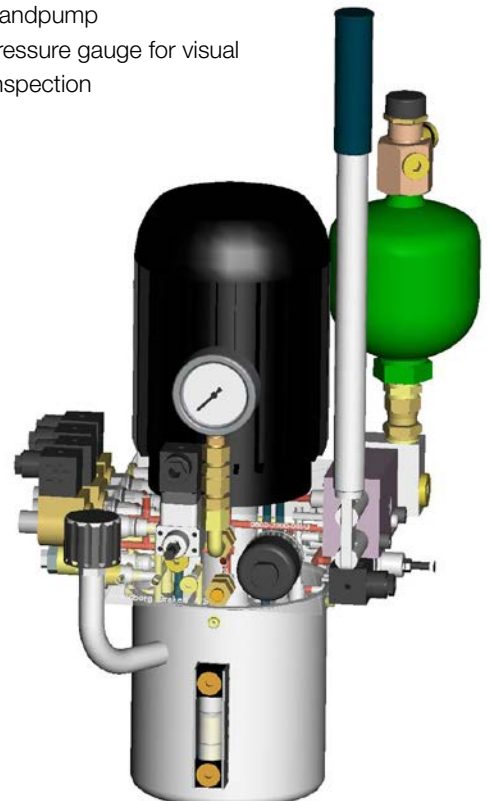
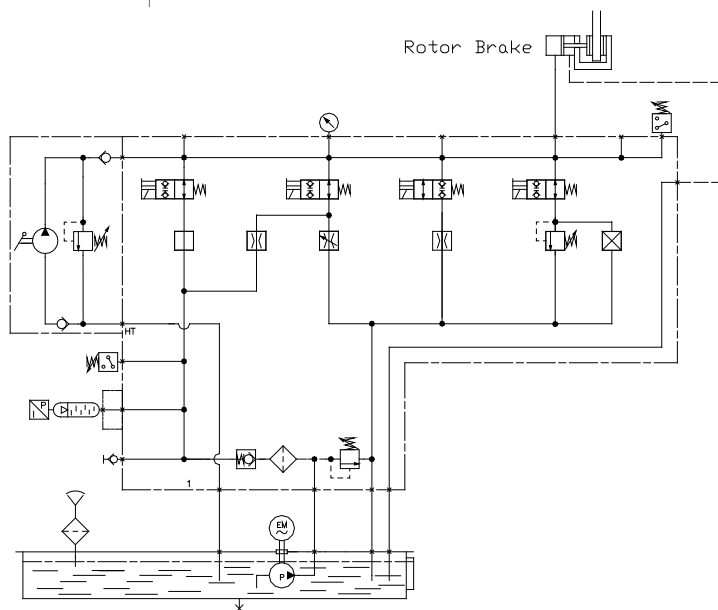

Example for a Compact Drive Wind Turbine

Specification

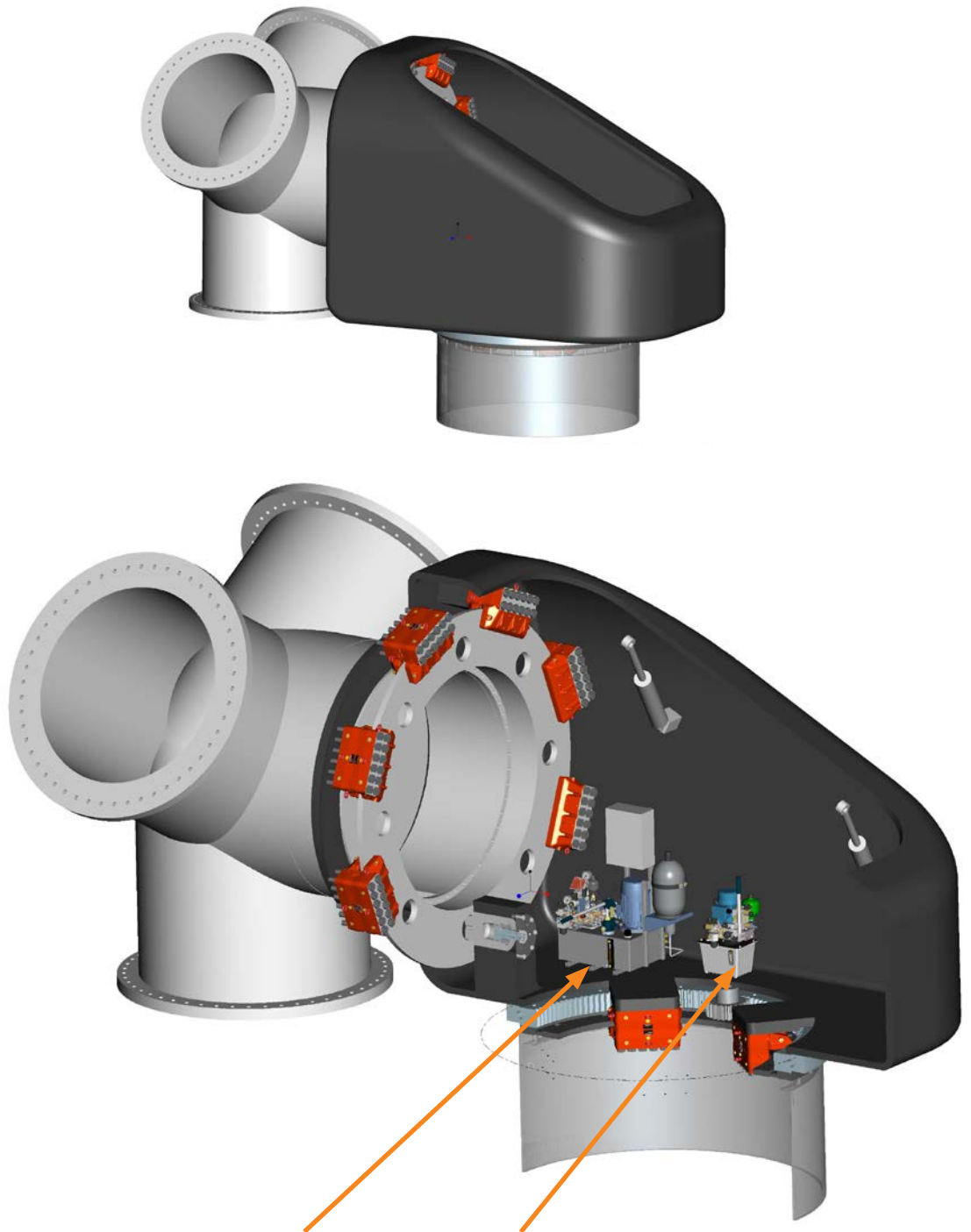

Combined hydraulic power unit
for rotor lock and roof hatch
control

Combined hydraulic power unit
for yaw brake and rotor brake
control

Example for a Compact Drive Wind Turbine

Specification

SYSTEM CIRCUIT

The electrical motor drives a hydraulic gearpump. The pump feeds the system accumulator, controlled by a pressure switch or a transmitter. The system pressure can be released manually by a shut-off cock or by manual override of valves. The high pressure filter between the pump and the system ensures the cleanliness of the hydraulic system. The certified pressure control valve ensures pressure relief in case of control failures.

Combined hydraulic power unit for activating rotor locks and roof hatch control

1110-0002-8XX

TYPICAL APPLICATION:

-Service hydraulic for multi-megawatt turbines

GENERAL FEATURES:

- compact and cost efficient design mounted on 25 liter tank
- sub components from qualified suppliers
- universal manifold
- robust asynchronous 400V/50Hz el. motor
- oil level + temperature control

OPTIONAL FEATURES:

- UL-approved electrical components
- drip pan
- electrical cabinet
- remote control operating panel
- customer specific electrical plugconnection
- cold climate version
- 690 V el. motor
- 60Hz
- Handpump
- pressure gauge for visual inspection

ROTOR LOCK CIRCUIT:

- adjustable pressure for rotor lock
- 4/3 valve for rotor lock control is protected by additional 2/2 valves
- 24h / 7 days pressure holding capacity
- ‘cylinder holding function’ included
- over pressure protection with pressure relief valves
- manual activation of the valve or via remote control
- ‘Auto-Rolo’ capable

ROOF HATCHES CIRCUIT:

- hyd. cylinder for hatches can be operated separately
- adjustable pressure
- manual activation of the valves or via remote control

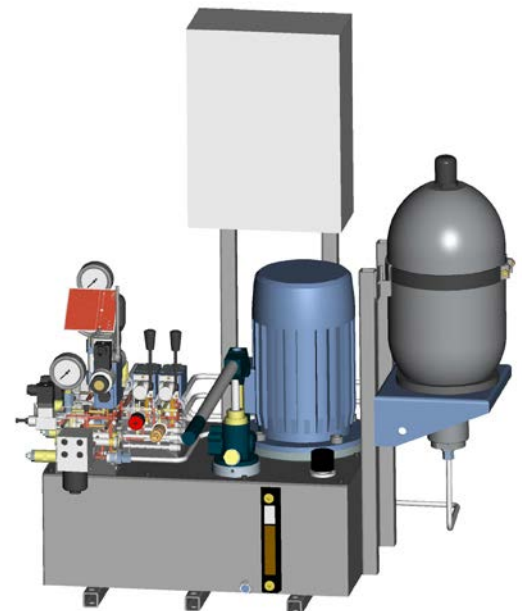
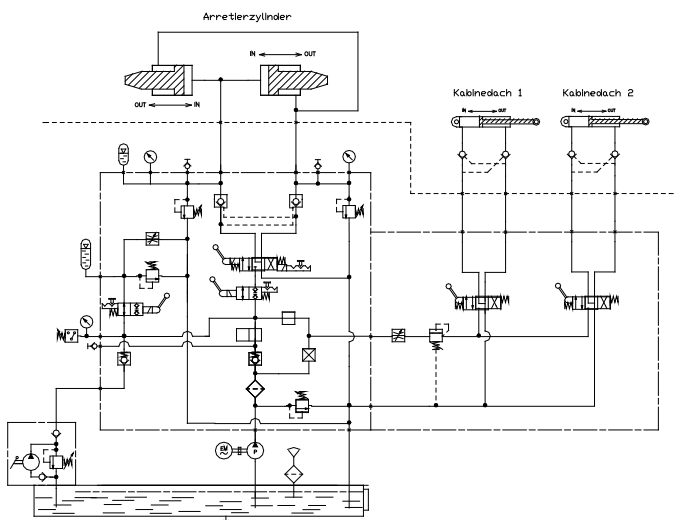

Example for a Compact Drive Wind Turbine

Specification

SYSTEM CIRCUIT

The electrical motor drives a hydraulic gearpump. The Pump feeds the system accumulator, controlled by a pressure switch or a transmitter. The system pressure can be released manually by shut-off cock or manual override of valves. The high pressure filter between the pump and the system ensures the cleanliness of the hydraulic system. The certified pressure control valve ensures pressure relief in case of control failures. Optional transmitter on system accumulator for checking the nitrogen pre-charge.

ROTOR BRAKE CIRCUIT:

- fail safe brake activation or idling function in case of power loss
- 24h / 7 days pressure holding capacity
- pressure switch or transmitter for brake status control

YAW BRAKE CIRCUIT:

- yaw brakes with 3 pressure levels, i.e.
 -)160 bar for holding function
 -)30 bar for yaw operation
 -)0 bar for cable loop unwinding operation
- flushing function with filter in return line
- 24h / 7 days pressure holding capacity
- pressure switch or transmitter for brake status control

Combined hydraulic power unit for active rotor brakes of BSAB series and yaw brake control

1010-0099-8XX

GENERAL FEATURES:

- compact and cost efficient design mounted on 6 liter tank
- 2/2 seat valve technology, leak oil free
- sub components from qualified suppliers
- universe manifold
- robust asynchronous 400V/50Hz el. motor
- oil level + temperature control

OPTIONAL FEATURES:

- UL-approved electrical components
- drip pan
- electrical cabinet
- customer specific electrical plug connection
- cold climate version
- 690 V el. motor
- 60Hz
- Handpump
- Pressure gauge for visual inspection

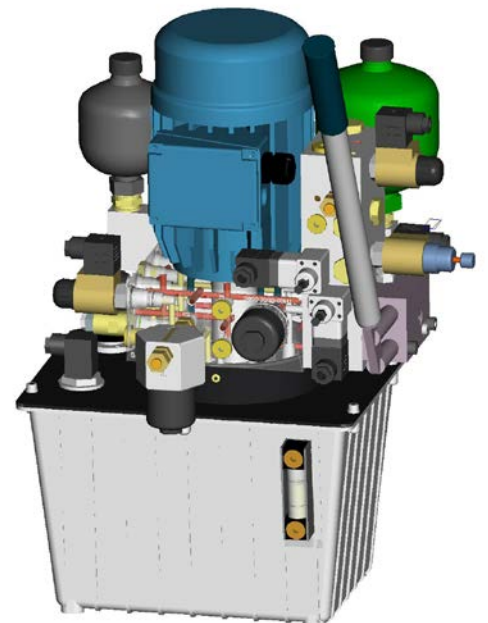
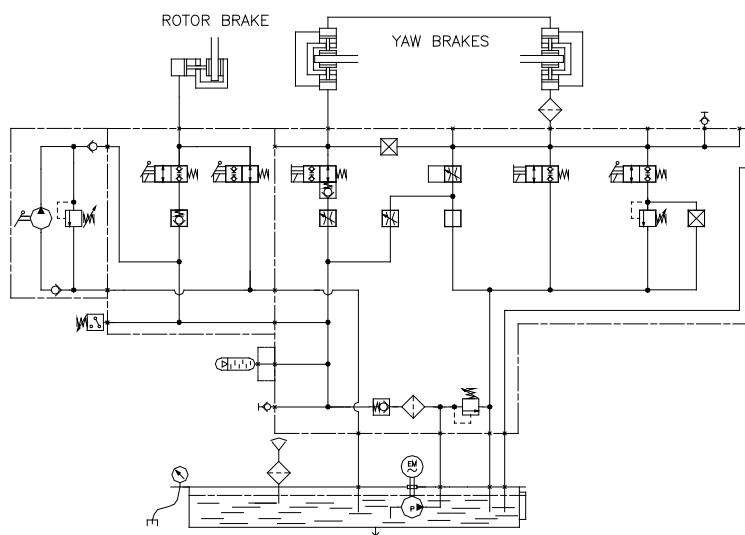

Example for a Compact Drive Wind Turbine

Specification

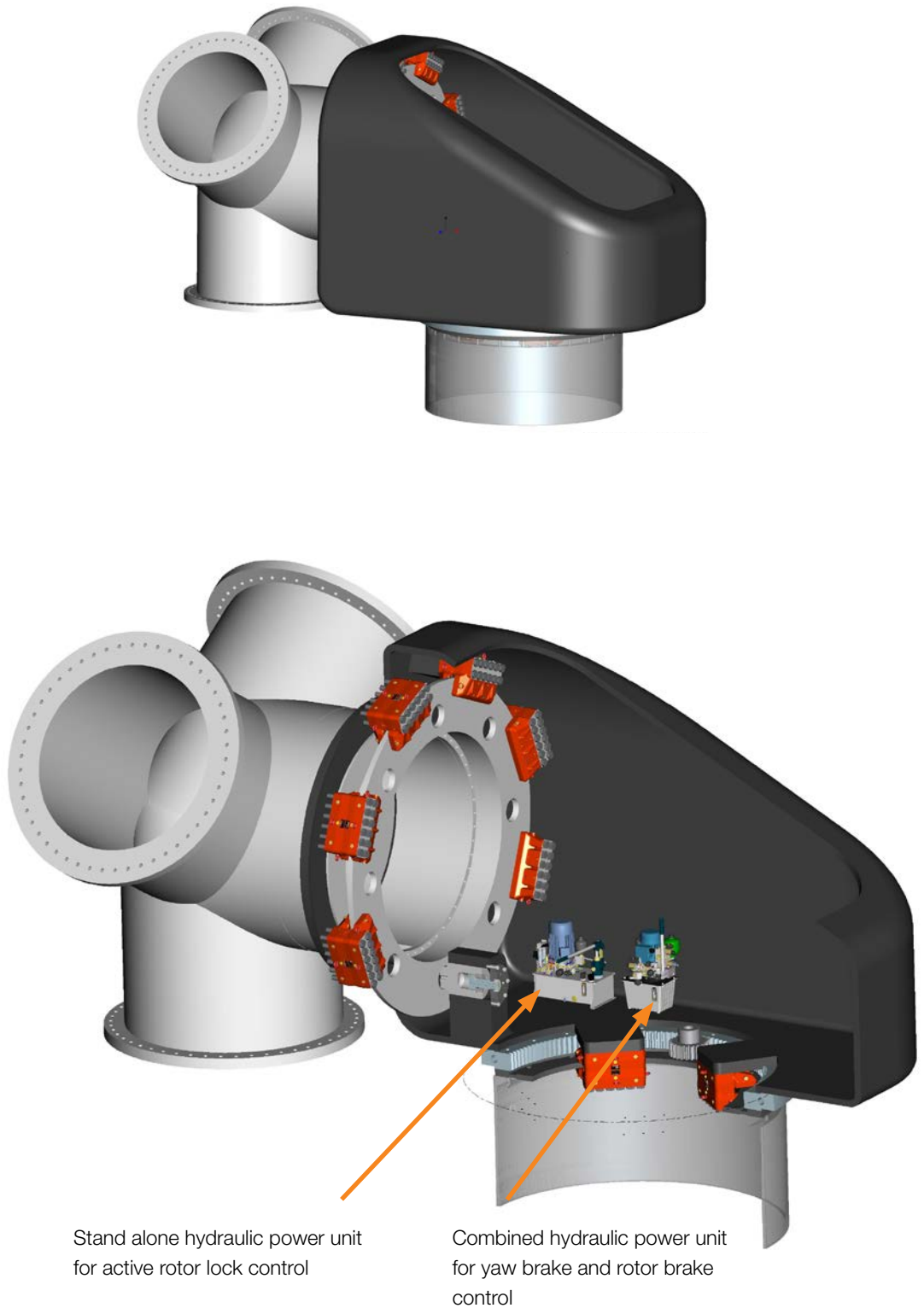

Example for a Compact Drive Wind Turbine

Specification

SYSTEM CIRCUIT

The electrical motor drives a hydraulic gearpump. The Pump feeds the system accumulator, controlled by a pressure switch or a transmitter. The system pressure can be released manually by shut-off cock or manual override of valves. The high pressure filter between the pump and the system ensures the cleanliness of the hydraulic system. The certified pressure control valve ensures pressure relief in case of control failures. Optional transmitter on system accumulator for checking the nitrogen pre-charge.

Combined hydraulic power unit for active rotor brakes of BSAB series and yaw brake control

1010-0099-8XX

GENERAL FEATURES:

- compact and cost efficient design mounted on 6 liter tank
- 2/2 seat valve technology, leak oil free
- sub components from qualified suppliers
- universal manifold
- robust asynchronous 400V/50Hz el. motor
- oil level + temperature control

ROTOR BRAKE CIRCUIT:

- fail safe brake activation or idling function in case of power loss
- 24h / 7 days pressure holding capacity
- pressure switch or transmitter for brake status control

OPTIONAL FEATURES:

- UL-approved electrical components
- drip pan
- electrical cabinet
- customer specific electrical plug connection
- cold climate version
- 690 V el. motor
- 60Hz
- Handpump
- Pressure gauge for visual inspection connection
- cold climate version
- 690 V el. motor
- 60Hz
- Handpump
- pressure gauge for visual inspection

YAW BRAKE CIRCUIT:

- yaw brakes with 3 pressure levels, i.e.
 -)160 bar for holding function
 -)30 bar for yaw operation
 -)0 bar for cable loop unwinding operation
- flushing function with filter in return line
- 24h / 7 days pressure holding capacity
- pressure switch or transmitter for brake status control

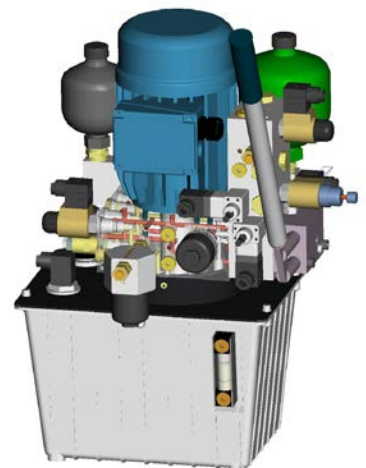
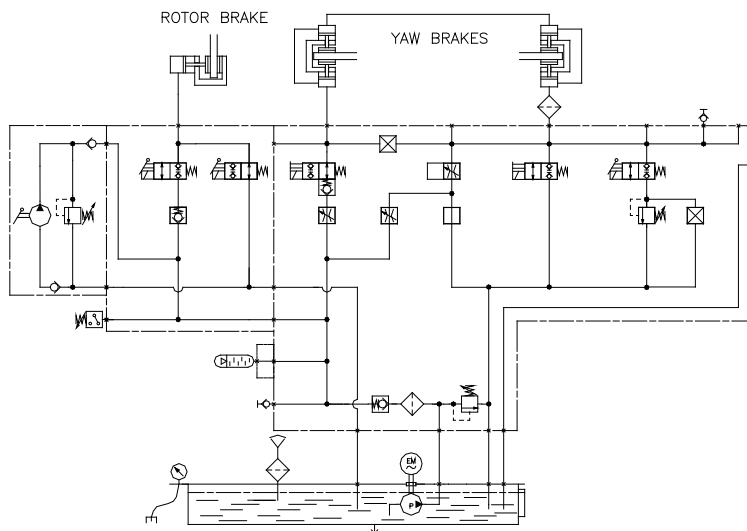

Example for a Compact Drive Wind Turbine

Specification

SYSTEM CIRCUIT

The electrical motor drives a hydraulic gear pump. The pump feeds the system accumulator, controlled by a pressure switch or a transmitter. The system pressure can be released manually by a shut-off cock or by manual override of valves. The high pressure filter between the pump and the system ensures the cleanliness of the hydraulic system. The certified pressure control valve ensures pressure relief in case of control failures.

- control valve is protected by additional 2/2 valve
- 24h / 7 days pressure holding capacity
- ‘cylinder holding function’ included
- manual activation of the valve or via remote control

ROTOR LOCK CIRCUIT:

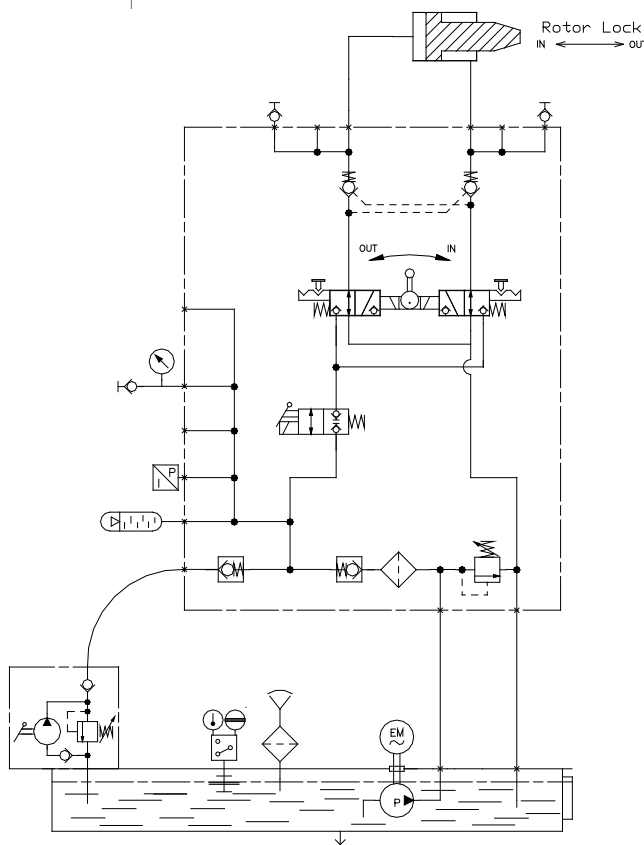

Stand-alone hydraulic power unit for rotor lock control

1110-0012-8XX

TYPICAL APPLICATION:

- Service hydraulic for multi-megawatt turbines

GENERAL FEATURES:

- compact and cost efficient design
- mounted on 20 liter tank
- sub components from qualified suppliers
- universal manifold
- robust asynchronous 400V/50Hz el. motor
- oil level + temperature control

OPTIONAL FEATURES:

- UL-approved electrical components
- drip pan
- electrical cabinet
- remote control operating panel
- customer specific electrical plug connection
- cold climate version
- 690 V el. motor
- 60Hz
- Handpump
- pressure gauge for visual inspection

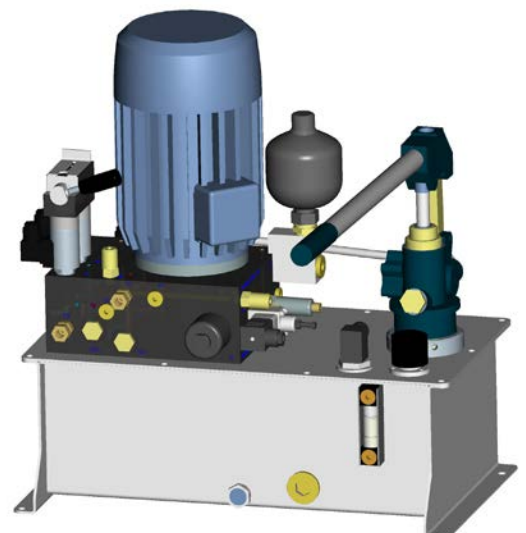

Example for a Compact Drive Wind Turbine

Specification

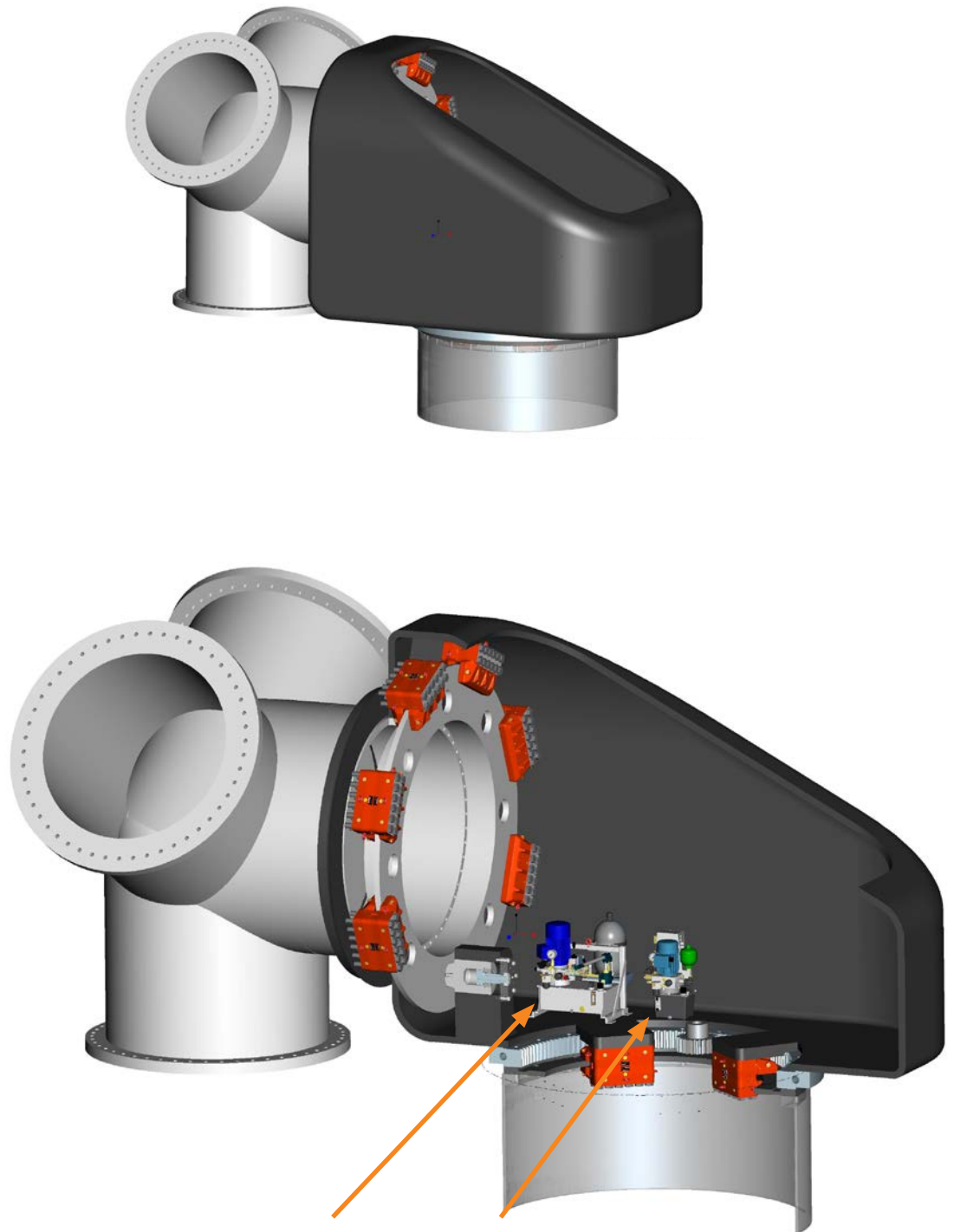

Combined hydraulic power unit
for active rotor lock
and rotor brake control

Stand alone hydraulic power unit
for yaw brake control

Example for a Compact Drive Wind Turbine

Specification

SYSTEM CIRCUIT

The electrical motor drives a hydraulic gearpump. The pump feeds the system accumulator, controlled by a pressure switch or a transmitter. The system pressure can be released manually by a shut-off cock or by manual override of valves. The high pressure filter between the pump and the system ensures the cleanliness of the hydraulic system. The certified pressure control valve ensures pressure relief in case of control failures. Optional transmitter on the system accumulator for checking the nitrogen pre-charge.

YAW BRAKE CIRCUIT:

- yaw brakes with 3 pressure levels, i.e.
 -)160 bar for holding function
 -)30 bar for yaw operation
 -)0 bar for cable loop unwinding operation
- flushing function with filter in return line
- 24h / 7 days pressure holding capacity
- pressure switch or transmitter for brake status control

Stand-alone hydraulic power unit for yaw brakes control

1010-0084-8XX

GENERAL FEATURES:

- compact and cost efficient design mounted on 6 liter tank
- 2/2 seat valve technology, leak oil free
- sub components from qualified suppliers
- universal manifold
- robust asynchronous 400V/50Hz el. motor
- oil level + temperature control

OPTIONAL FEATURES:

- UL-approved electrical components
- drip pan
- electrical cabinet
- customer specific electrical plug connection
- cold climate version
- 690 V el. motor
- 60Hz
- Handpump
- pressure gauge for visual inspection

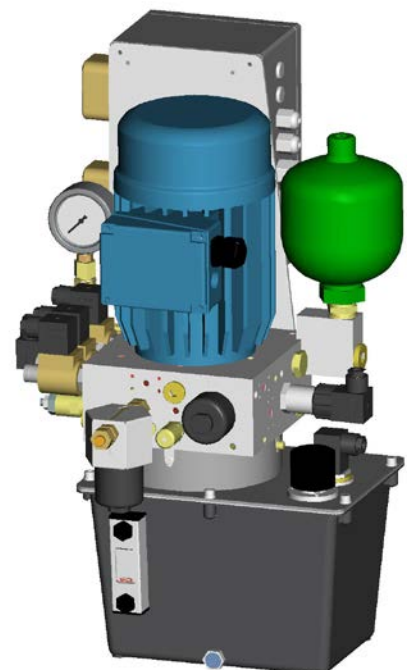
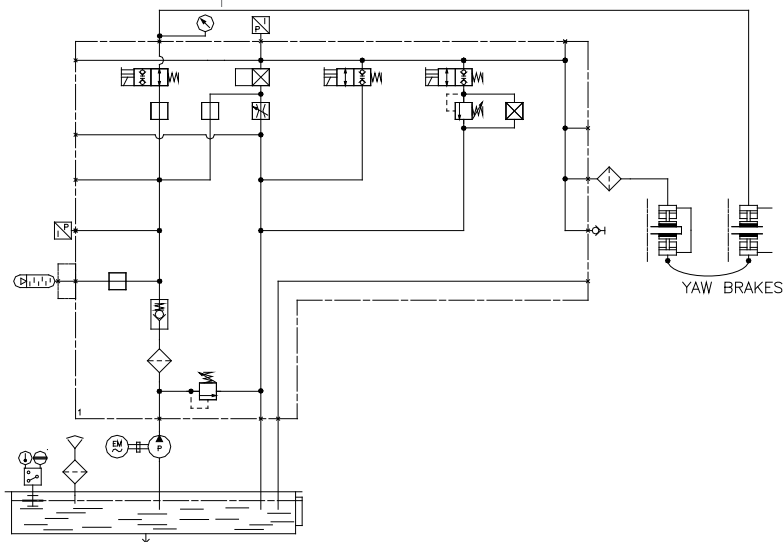

Example for a Compact Drive Wind Turbine

Specification

SYSTEM CIRCUIT

The electrical motor drives a hydraulic gearpump. Pump feeds the system accumulator, controlled by pressure switch or transmitter. System pressure can be released manually by cock or manual override on valves. High pressure filter between pump and system ensures cleanliness of hyd. system. Certified pressure control valve ensures pressure relief in case of control failures. Optional transmitter on system accumulator for checking the nitrogen pre-charge.

ROTOR BRAKE CIRCUIT:

- fail safe brake activation or idling function in case of power loss
- 24h / 7 days pressure holding capacity
- delay time according to customer demands
- pressure switch or transmitter for brake status control
- flushing function with filter in return line

ROTOR LOCK CIRCUIT:

- adjustable pressure for rotor lock
- 4/3 valve for rotor lock control is protected by additional 2/2 valves
- 24h / 7 days pressure holding capacity
- 'cylinder holding function' included

Combined hydraulic power unit for active rotor brakes and rotor lock control

1010-0124-804

GENERAL FEATURES:

- compact and cost efficient design mounted on 20 liter tank
- 2/2 seat valve technology, leak oil free
- sub components from qualified suppliers
- universe manifold
- robust asynchronous 400V/50Hz el. motor
- oil level + temperature control

OPTIONAL FEATURES:

- UL el. components
- drip pan
- el. cabinet
- customer specific el. plug connection
- cold climate version
- 690 V el. motor
- 60Hz
- Handpump
- manometer for visual inspection

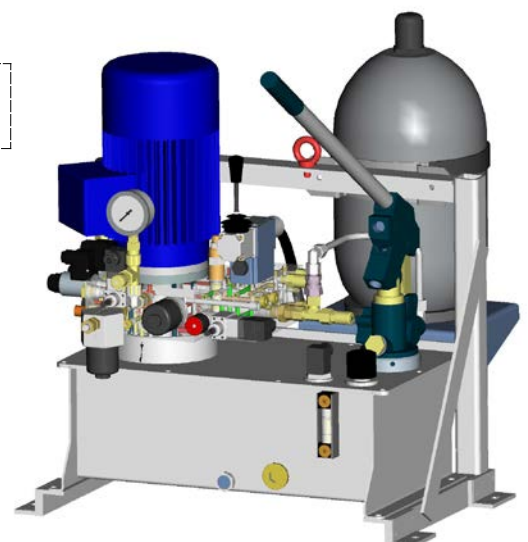
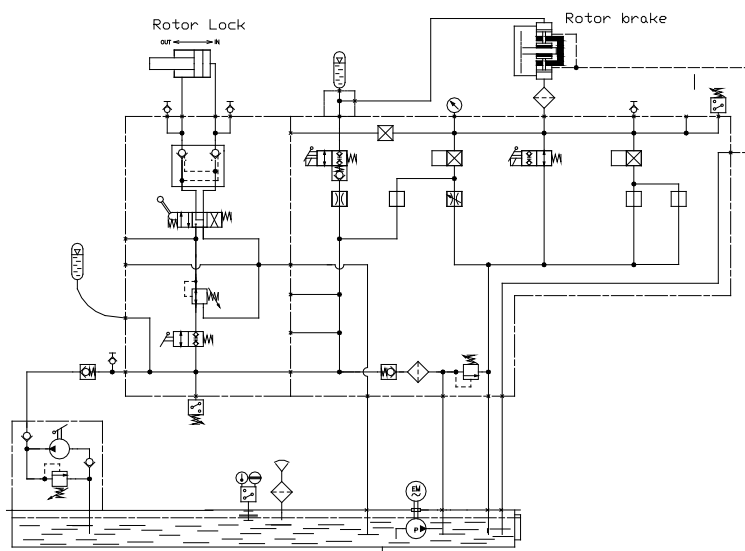

Notes:

Premier Industrial Company Leading Brands

OTHER PRODUCT SOLUTIONS FROM **REGAL REXNORD**

Our comprehensive product offerings include various types of clutches and brakes, overrunning clutches, engineered bearing assemblies, gearing and gear motors along with linear motion products, belted drives, couplings, limit switches, precision motors, drives & controls, and miniature motors. With thousands of product solutions available, Regal Rexnord provides true single source convenience while meeting specific customer requirements. Many major OEMs and end users prefer Regal Rexnord products as their No. 1 choice for performance and reliability.

WWW.REGALREXNORD.COM



Electric Clutches & Brakes

Stromag
Warner Electric



Precision Motors & Automation

Kollmorgen



Heavy Duty Clutches & Brakes

Industrial Clutch
Stromag
Svendborg Brakes
Twiflex
Wichita Clutch



Miniature Motors

Portescap



Overrunning Clutches

Formsprag Clutch
Marland Clutch
Stieber



Linear Systems

Thomson



Engineered Couplings & Universal Joints

Ameridrives
Bibby Turboflex
Guardian Couplings
Huco
Lamiflex Couplings
Stromag
TB Wood's



Specialty Components

Kilian
Stromag
TB Wood's



Gear Drives & Gear Motors

Bauer Gear Motor
Boston Gear
Delroyd Worm Gear
Nuttall Gear

Svendborg Brakes Facilities

Europe

Jernbanevej 9
DK-5882 Vejstrup - Denmark
+45 63 255 255
sb@svendborg-brakes.com

*Industrial Brakes and
Brake Systems*

Global Representations

Australia

Perth
+61 (0) 8 94 160300
sales@altramotion.com.au

Newcastle
+61 (0) 8 94 160300
sales@altramotion.com.au

Brisbane
+61 (0) 8 94 160300
sales@altramotion.com.au

Brazil
+55 11 4615-6300 /
+55 11 5679-6553
altra.vendas@altramotion.com

Chile
Coquimbo
+56 23 203 9150
sa@svendborg-brakes.com

Santiago
+56 23 203 9150
sa@svendborg-brakes.com

China

+86 21 60580600
sb@svendborg-brakes.com

Czech Republic

+420 2 51 68 01 68
jan.mikyska@svendborg-brakes.cz

Denmark

+45 63 255 255
sb@svendborg-brakes.com

Germany

+49 5422 9272 000
sb@svendborg-brakes.com

India

+91 83909 97970
milind.sule@altramotion.com

Korea

+82 10 9703 0979
jong.lee@svendborg-brakes.com

Perú

+51 959 224488 /
+51 959 223653
pe@svendborg-brakes.com

Poland

+48 605 765 904
biuro@vitech.pl

South Africa

+27 83 382 2479
sales@sintech.co.za

Spain

+34 (975) 2336 55
sb@svendborg-brakes.com

USA

+1 (303) 285 1271
na@svendborg-brakes.com



Scan to see all
the brands of
Regal Rexnord

Neither the accuracy nor completeness of the information contained in this publication is guaranteed by the company and may be subject to change in its sole discretion. The operating and performance characteristics of these products may vary depending on the application, installation, operating conditions and environmental factors. The company's terms and conditions of sale can be viewed at <http://www.altramotion.com/terms-and-conditions/sales-terms-and-conditions>. These terms and conditions apply to any person who may buy, acquire or use a product referred to herein, including any person who buys from a licensed distributor of these branded products.

©2023 by Svendborg Brakes LLC. All rights reserved. All trademarks in this publication are the sole and exclusive property of Svendborg Brakes LLC or one of its affiliated companies.