

Turning, Locking, & Braking Systems for Marine Propulsion Applications

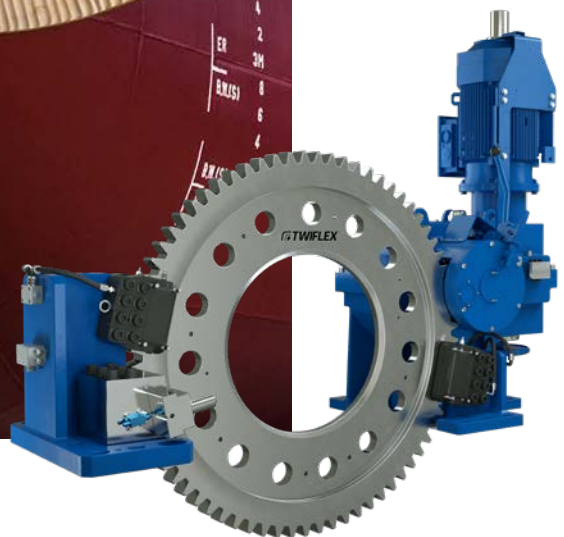

TURNING, LOCKING AND BRAKING IN MARINE PROPULSION SYSTEMS



Turning, Locking & Braking Systems
by Twiflex

The Twiflex system comprises a Turning gear, Locking device, and shaft Brake (TLB) together with a power unit (e.g. Hydraulic Powerpack) and a control panel for local operation of the system close to the equipment. The TLB is available as a continuous turning option, as shown, or as an indexing system using a simple hydraulic 'push-pull' arrangement with the brakes and brake disc to incrementally inch the propeller shaft for maintenance and accurate alignment. For a more cost effective solution, a simple manual option is also available for this purpose.

TURNING

TURNING: Low power turning while in port

BEARING CONDITIONING: Eliminates bearing damage due to setting when vessel is moored in port for extended periods

SHAFT ROTATION: Enables shaft rotation during installation and maintenance

POSITIONING: Optimizes propeller blade positioning while at sea and during maintenance and installation

ROTATION: Provides the ability to rotate the shaft when drive is disengaged

INSTALLATION: Quicker and easier installation and setting of drive components

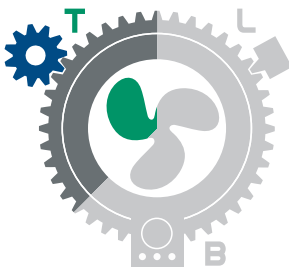

LOCKING

INCREASED SAFETY: Enables locking of the shaft for maintenance

IMPROVED FUEL EFFICIENCY: Used to lock shaft to prevent a wind milling effect while in operation (twin or multiple screw)

SHAFT LINE PROTECTION: Used to protect redundant or damaged shaft line while at sea

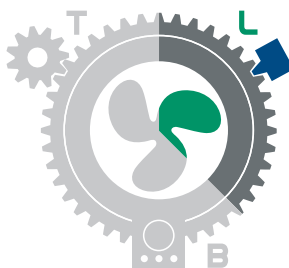

BRAKING

FASTER DIRECTIONAL CHANGES: Used to shorten stopping of rotating shaft or in order to change direction

- Improved maneuverability (twin or multiple screw) allowing better steering for rapid directional change
- Crash astern and crash stop

REDUCE LOAD ON PROPULSION SYSTEMS: used to shorten stopping of rotating shaft when coming into port

- Controlled stopping to protect drive components including gearbox when lubrication system has failed

PREVENT WIND MILLING EFFECT: Shaft holding when unpowered propeller rotates due to the flow stream

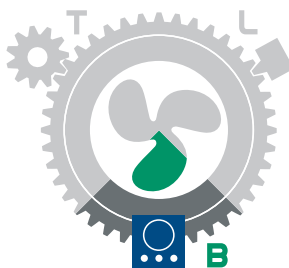

ADVANTAGES OF THE TWIFLEX TURNING, LOCKING AND BRAKING (TLB) SYSTEM

When purchasing a complete turning gear system integrated with locking and braking from Twiflex, customers can consolidate three separate interfaces into one, multi-functional solution: Turning 'T', Locking 'L', and Braking 'B', which enables customers to save dimensional space, decrease installation and maintenance time and reduce costs.

- Twiflex provides a superior solution with a continuous turning design for the same price as a comparable indexing solution
 - Infinite positioning
 - Fixed speed in both directions (variable as an option)
 - Balanced load profile
 - Quicker & safer stopping
- Fully modular solution providing the customer an option to select each function T,L,B, individually or combined TL, TB or LB in addition to the complete TLB system
- Flexible designs to meet customer requirements with full design and build completely in-house
 - Many configurations available based on five standard brake disc sizes with turning torques up to 454 kNm and turning speeds up to 2.6 rpm depending on configuration.
 - Wide range of well proven locking devices and brakes with torques up to 862 kNm based on the standard range. Custom disc sizes are available.
- Local and Remote operation to suit customer preference
- Manual Turning and Locking available for power failure condition

A superior solution from a single source

- Complete System Provider: brakes, actuation methods, controls, hydraulics, locking devices, etc.
- Strong Design & Technical Competence
- Full Design & Build In-House
- Custom Modular Solutions
- Renowned Testing Facilities
- Balanced Braking
- Superior Continuous Turning Design
- Extensive Marine Application Expertise
- Brand Longevity
- Marine Service Capabilities



Customized solutions to meet individual vessel requirements



MODULAR TWIFLEX TLB SYSTEM FOR MARINE PROPULSION

The Twiflex TLB system is fully modular and can be supplied as a complete TLB package or variations as listed and shown below:

- 'T' Turning only
- 'L' Locking only
- 'B' Braking only
- 'TB' Turning and Braking
- 'LB' Locking and Braking
- 'TL' Turning and Locking

All systems are fully monitored and designed to provide an interface with the customers bridge control.

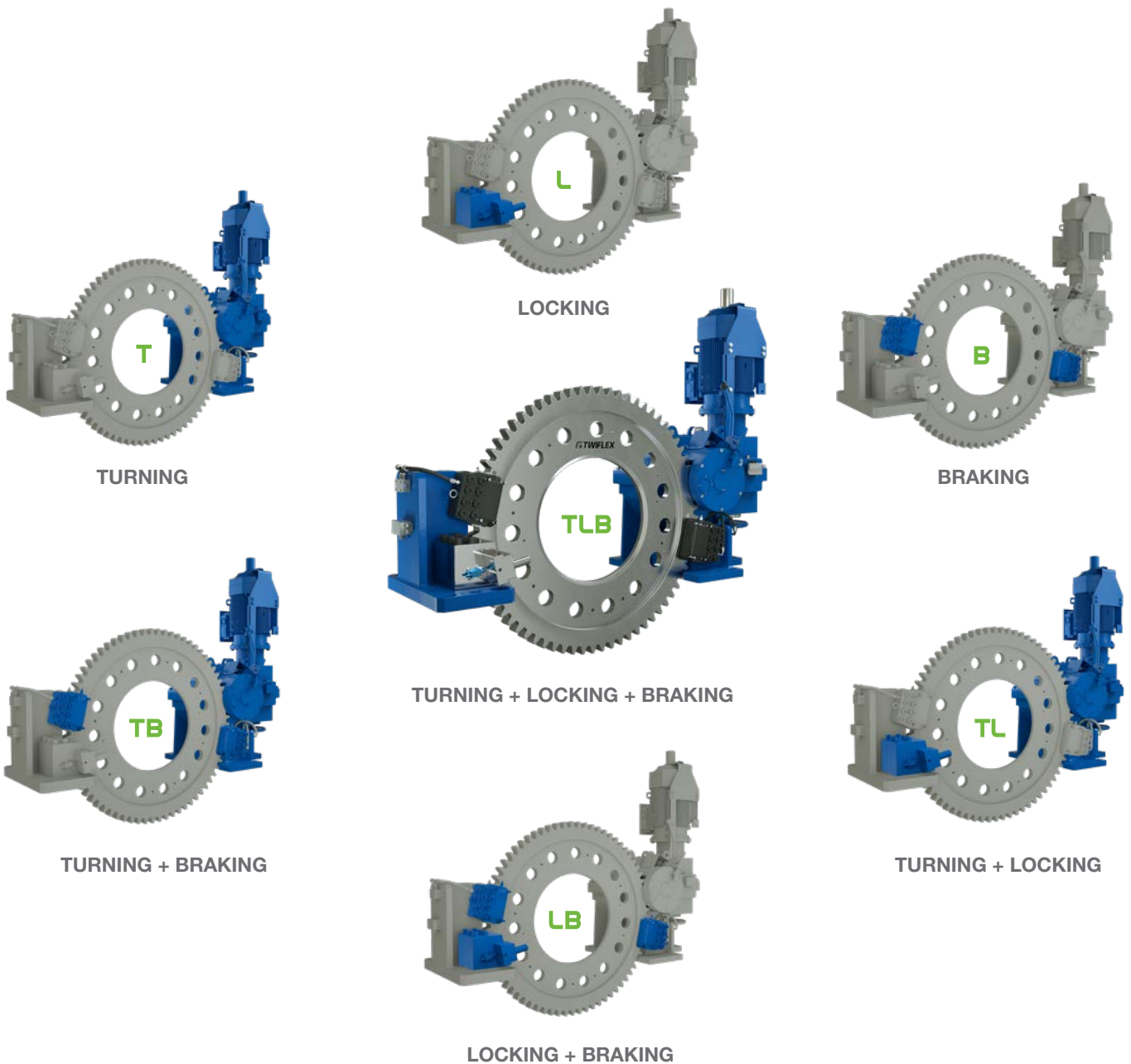

REGAL REXNORD HAS MANY YEARS OF EXPERIENCE DESIGNING AND SUPPLYING HYDRAULIC, ELECTRO-PNEUMATIC, AND AIR-OVER-OIL CONTROLS FOR BRAKES AND CLUTCHES USED IN THE MARINE INDUSTRY.

The TLB system includes a fully monitored control system with a remote panel offering local control. While in normal operation, the system is operated and monitored by the ship's bridge control allowing only the brakes to be applied, for example, in an emergency condition or for fast maneuvering to provide rapid directional change for twin screw vessels. In local control, the turning gear and locking device can be operated along with the brakes allowing full TLB control.

For installations where braking and/or locking is required, power units can be supplied in various options (air, hydraulic, air-over-oil) along with an operating panel to provide basic control and monitoring to suit.

Regal Rexnord also offers a full range of direct pneumatic applied spring release scissor and dual spring brakes along with air-over-oil systems to meet both ship supply options.



TYPICAL TWIFLEX TLB POWER UNIT AND CONTROL

WHY DO CUSTOMERS SELECT **TWIFLEX** TLB SYSTEMS?



Problem:

A leading global marine propulsion system OEM required a unique drive shaft turning, locking and braking solution for use on a next-generation ice-breaking vessel. Controlled locally or from the bridge, the equipment fitted to each of the three propeller drives rotates and holds the propulsion shafts during maintenance. It also stops and locks the drive shaft to prevent the propeller from rotating when the vessel is moored in a flow stream.

Solution:

The custom Twiflex TLB-180 produces a continuous turning torque of 140 kNm at 0.6 rpm in both directions with a dynamic braking capacity and static locking torque rated up to 180 kNm. The system features a 1.5m (4.9 ft) diameter split disc with a gear tooth profile which easily mounts onto a flange without the need to disassemble the main propulsion shaft.

TLB SYSTEM SPECIFICATIONS

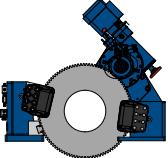
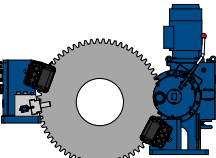
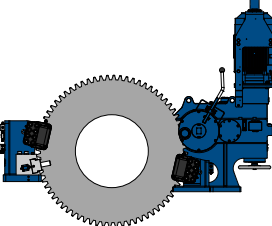
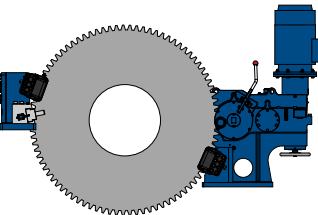
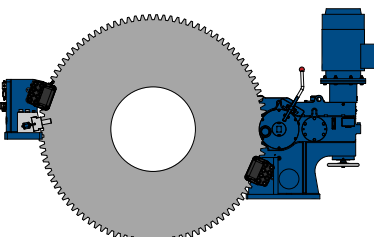
	Disc Dia. (mm)	Turning Torque (Nm)		Turning Speed/ (rpm)		Locking Torque (Nm)	Braking Torque (Nm)		
		Min	Max	Min	Max	Nom	Min	Max	
	TLB80-C	800	14300	158030	0.38	2.64	32000	15970	31950
	TLB120-C	1200	21480	237040	0.25	1.76	72000	36040	72070
	TLB150-C	1500	26850	296300	0.20	1.41	190000	94720	189450
	TLB200-C	2000	35800	395060	0.15	1.06	214000	106790	213580
	TLB230-C	2300	41170	454320	0.13	0.92	862000	430840	861670

- Braking Torques are calculated using direct applied, spring release hydraulic brakes. Direct applied, spring release pneumatic brakes are also available
- Max operating pressure used in the above calculations is 150 bar
- Coefficient of Friction (μ) has been taken as 0.4
- Max. Braking Torque assumes 2 off brakes (same model and rating) are used on a single brake disc
- Configurations shown are complete TLB systems with continuous turning (-C). Indexing (-I) or manual systems (-M) are available upon request
- All Turning Gear options include the facility for manual turning in addition to normal operation
- The geared brake disc can be supplied as a solid or as a split design

TLB SYSTEM DIMENSIONS

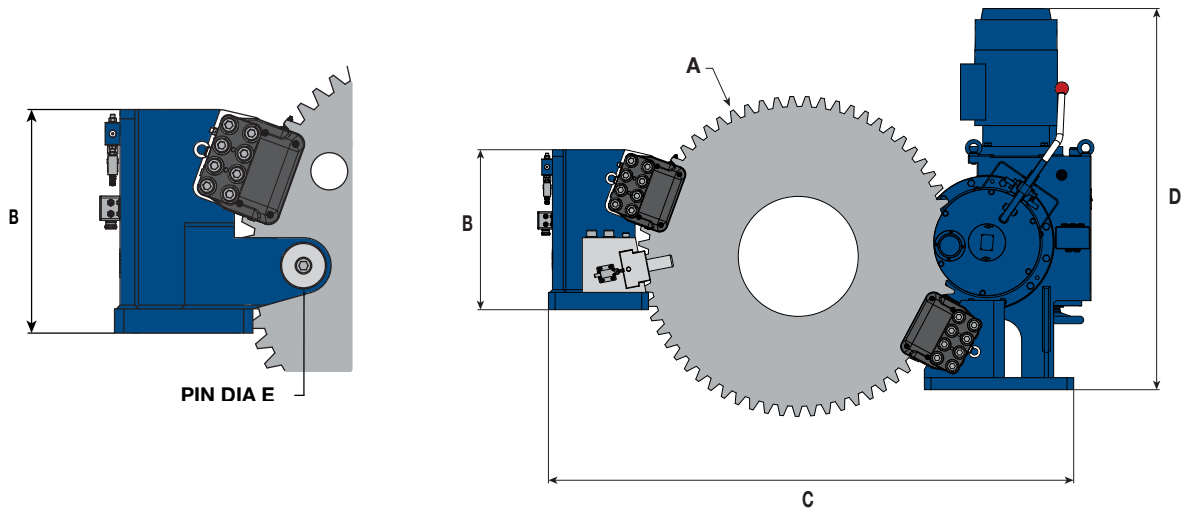

Dimension	TLB80-C	TLB120-C	TLB150-C	TLB200-C	TLB230-C
A	800	1200	1500	2000	2300
B	500	600	600	600	600
C	1350	2000	2650	3450	3700
D	1200	1450	1950	1950	1950
E	75	100	100	100	150

All dimensions shown in mm

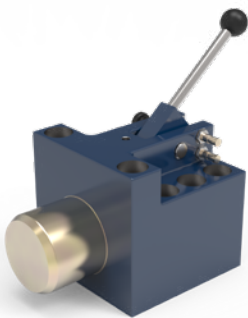

LOCKING DEVICES

Twiflex also offers a range of devices available as either axial locking, using holes in the disc face (or gearwheel as part of the Twiflex Turning, Locking, Braking TLB system), or radially locking using a tapered pawl which is designed to engage in slots machined in the outer disc or coupling periphery.

- Manually operated as standard, hydraulic and mechanical options upon request
- Engineered custom solutions and status monitoring can be provided

Twiflex Facilities

Europe

United Kingdom

9 Briar Road, Twickenham
Middlesex TW2 6RB - England
+44 (0) 20 8894 1161
info@twiflex.com
sales@twiflex.com

Industrial Brake Systems

Amphill Road
Bedford, MK42 9RD - UK
+44 (0)1234 350311

Industrial Brake Systems

Germany

Hatschekstraße 36
69126 Heidelberg - Germany
+49 (0) 6221-304719
twiflex-sales@stieber.de

Industrial Brake Systems

North America

USA

2800 Fisher Road
Wichita Falls, TX 76302 - USA
940-723-3483
Toll free: 844-723-3483
twiflex.info@twiflex.com

Industrial Brake Systems

Asia Pacific

Australia

+61 2 9894 0133

China

+86 21 5169-9255

Hong Kong

+852 2615 9313

Singapore

+65 6487 4464

Taiwan

+886 2 2577 8156

Thailand

+66 2322 5527

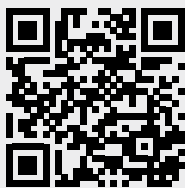

Scan to see all
the brands of
Regal Rexnord

Neither the accuracy nor completeness of the information contained in this publication is guaranteed by the company and may be subject to change in its sole discretion. The operating and performance characteristics of these products may vary depending on the application, installation, operating conditions and environmental factors. The company's terms and conditions of sale can be viewed at <https://www.twiflex.com/company/terms-and-conditions>. These terms and conditions apply to any person who may buy, acquire or use a product referred to herein, including any person who buys from a licensed distributor of these branded products.

©2023 by Twiflex LLC. All rights reserved. All trademarks in this publication are the sole and exclusive property of Twiflex LLC or one of its affiliated companies.