

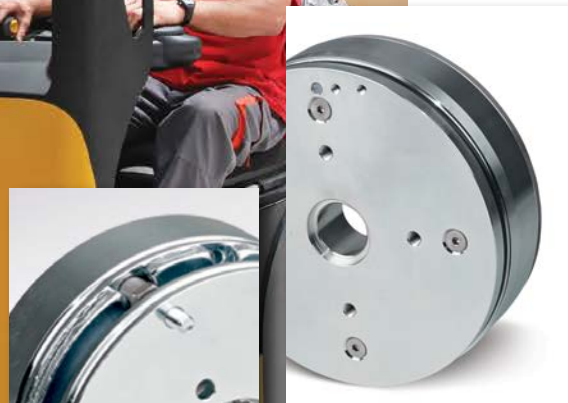

Braking Solutions for the Forklift Truck & Electric Vehicle Market



Forklift Truck & Electric Vehicle Braking Solutions

WARNER ELECTRIC FORKLIFT & ELECTRICAL VEHICLE BRAKES



LWB 4EB

Electrically-Applied Variable Torque Load Wheel Brake
Service-only brake positioned inside front load wheel.



LWB 4PMB

Electrically Released, Variable Torque Load Wheel Brakes
Parking and service brake positioned inside front load wheel.



Varistop

Electrically Released, Variable Torque Traction Motor Brakes
Service and parking brake installed on the traction motor.



PK (Very Thin)

Spring-Applied Motor Brakes
Parking and emergency stopping standard safety brakes



PK-Enclosed Design

Spring-Applied Motor Brake, Captive Design
Parking and stopping standard brake for outdoor applications



Dual Stage PK

Dual Stage Spring Applied Brakes
Two-step brake engagement prevents harsh dynamic E-stop braking



EDI

Spring Applied Dual Disc Brakes
Parking and emergency braking functionality



CBTB

Electromagnetic Brake
High dissipating motor brake



AP

Spring-Applied Brakes
Parking and emergency stopping brake



Special Designs

ERD H, SAE "Bolt-On"



Electronics and WES

NEW

Advanced Non-Stick Friction Material

For cold room and outdoor environments

Warner Electric engineers have developed a proprietary friction material specifically designed for cold room and outdoor environments with high moisture levels and wide temperature differentials.

Most standard friction materials tend to get sticky and lose their effectiveness in these cold, harsh conditions.

Warner Electric's new friction material has proven to retain stable torque in between static parking and high energy service and emergency stopping during rigorous climate chamber and endurance testing, as well as extensive field testing.

The new material is available on all PK Series motor brakes.

NEW

High Speed High Energy Friction Material

For high capacity braking requirements

The new W134 friction material has been designed to equip the CBTB series. This non-stick material can also be fitted on other brake series in certain conditions. Previously, the standard material was able to handle 57kJ at 900rpm, however, the new W134 is able to handle up to 190kJ at 1300rpm.

Warner Electric is a world leader in the design and manufacture of electromagnetic brakes and clutches for battery powered vehicles. A full range of traction motor and load wheel brakes is offered, including customized solutions to meet specific performance and installation requirements. Warner Electric braking solutions are designed with the industry's toughest challenges in mind, utilizing proprietary technology to analyze magnetic properties of the brake, brake interfaces and surroundings.



Electric Counter Balance

- PK35 (standard & enclosed)
- PK60 (standard & enclosed)
- PK100 & PK170
- SAE Series
- CBTB



Ride On Pallet Truck

- PK20 & PK35
- Dual Stage PK
- ERD35H



High Level Order Picker

- PK20, 35 & 60
- ERD35H
- Varistop Traction Motor
- LWB 4EB
- LWB 4PMB



Stacker & Pallet Trucks

- PK5, 10, 20, 35 & 60
- PK35 (enclosed)
- PK60 (enclosed)
- Dual Stage PK



Reach Truck

- PK35, 60 & 100
- LWB 4EB
- LWB 4PMB
- Varistop Traction Motor



Very Narrow Aisle

- PK35 (enclosed)
- PK60 (enclosed)
- LWB 4EB
- LWB 4PMB

Forklift Truck & Electric Vehicle Braking Solutions

LWB BRAKES



4EB Electrically Applied, Variable Torque Load Wheel Brakes

Service variable torque brake positioned inside front load wheel

The 4EB series is an electromagnetic stationary single-face brake with zero backlash, designed for dry use. When the coil is energized by a DC voltage a magnetic field is generated which attracts the armature disc to the magnet assembly. The armature disc is connected to a rotating member of the drive. Various brake configurations are available to suit different drive installation requirements.

- Compact design fits inside load wheel
- Operator controlled variable torque
- High torque to size ratio
- Single disc
- Zero drag torque

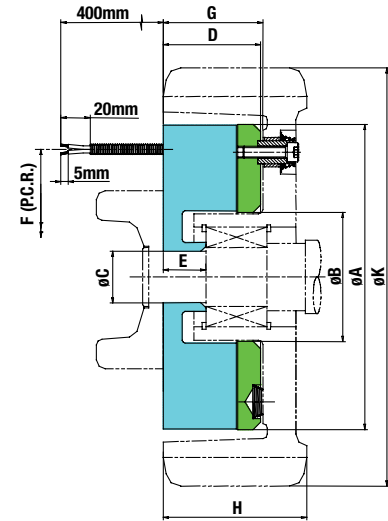

Model/Size			4EB060	4EB070	4EB080	4EB090	4EB-MP090
Rated Dynamic Torque	(Nm)	*	50-150	350-500	450-600	550-700	800
	(lb.ft.)	*	37-111	258-369	332-443	406-516	590
Operating Voltage	(Vdc)	*			12-48		
Power	(Watts)	*		72	96	106	
Outer Diameter – ØA	(mm)	*	160	207	219	246	246
Inner Diameter – ØB	(mm)	*		88	93	105	
Overall Length – C	(mm)	*		74	77	82	
Location Diameter – ØD	(mm)						
Location Diameter Length – E	(mm)						
Fixing Hole Requirements Size/Quantity/Location	(mm)						Customer Specified

* Features can be customized to suit specific application requirements.

LWB BRAKES



4PMB Electrically Released, Variable Torque Load Wheel Brakes

Service and parking brake positioned inside front load wheel

The 4PMB load wheel brakes provide parking and “variable torque” service braking. The compact designs are positioned inside the load wheels.

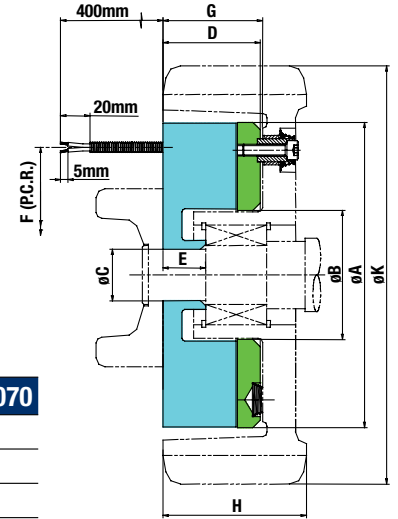

Model/Size		4PMB055	4PMB070	4PMB090	4PMB-MP070	
Rated Static Torque	(Nm)	*	80	190	300	375
	(lb.ft.)	*	59	140	221	277
Rated Dynamic Torque	(Nm)	*		150	270	
	(lb.ft.)	*		110	200	
Operating Voltage	(Vdc)	*				
Power	(Watts)	*		72	97	
Outer Diameter – ØA	(mm)	*	140	207	246	207
Inner Diameter – ØB	(mm)	*		95	93	
Overall Length – C	(mm)	*		80	82	
Location Diameter – ØD	(mm)					
Location Diameter Length – E	(mm)					
Fixing Hole Requirements Size/Quantity/Location	(mm)					Customer Specified

* Features can be customized to suit specific application requirements. Static and dynamic torque can be increased by using reverse polarity at brake engagement.

VARISTOP BRAKES



Varistop Electrically Released, Variable Torque Motor Brakes

Service and parking brake positioned on traction motor

Varistop brakes are installed on the traction motor. The design is a stationary single-face brakes with zero backlash designed for dry use.

Due to its compact design and capability to monitor braking torque, this brake is well-suited for the ‘man lift’ type forklift applications.

- For service braking, emergency stop and parking
- Electric or hydraulic versions available
- High torque within a compact space envelope
- Multi-step braking versions available

Forklift Truck & Electric Vehicle Braking Solutions

PK (VERY THIN) BRAKES



Spring-Applied Motor brakes

Parking and emergency stopping standard safety brakes

The PK (Very Thin) range is a pre-assembled on/off dry safety electromagnetic brake. This safety brake is used for parking and emergency as well as some service braking. The AC motor is used in combination with the PK brake for regenerative braking of the truck. The brake can be fitted with various friction materials, in addition to standard are also available a high torque and high energy materials depending on the application. The coil can be designed for single or dual voltage and pulse width modulation power supply to reduce power consumption and maintenance.

The benefits of this cost competitive range include; one piece design for easy assembly, lower power consumption, longer battery life, and overall lower maintenance costs. The low profile design is particularly suitable for back to back dual drive configurations such as sit trucks and boom lifts.

- High torque within a compact space envelope
- Multi-step braking versions available
- Low profile space saving design
- Dust cover option
- IP20 standard & IP43 with optional dual cover and end cap

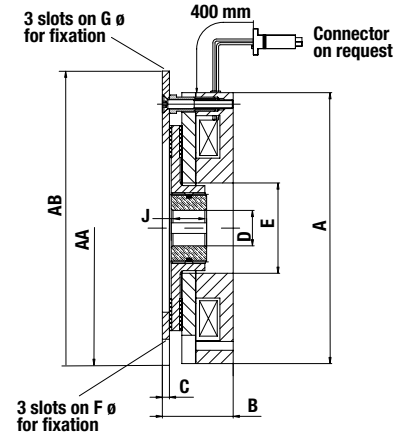

Size	005	010	020	035	060	100
Static Torque (Nm)*	9	21	40	70	125	200
Static Torque (lb. ft)*	6.6	15.5	29.5	51.6	92.2	147.5
A	82	96	133	153	164	184
B	41.5	39.7	43	43	59	75
C	3.2	3.2	4.5	6	6	10
D	10/15H7	15/20H7	15/20H7	19.05/20/25H7	20/25/30H7	25/30/35H7
J	18	20	20	25	30	30
E	31	28.5	43.5	51	59	70
F	72 (3xM4)	90 (3xM5)	112 (3xM5)	132 (3xM5 or M6)	145 (3xM8)	170 (3xM8)
G	90 (3xM5)	112 (3xM5)	132 (3xM5)	145 (3xM6)	170 (3xM8)	196 (3xM8)
AA small Flange	82	96	133	153	164	184
AB large Flange	100	115	138	178	185	215
Ambient Temperature	Minus 20 Plus 60 Degree C					
Voltage	Pulse Width Modulation - based on customer requirements					

* Minimum torque over the life of a brake.

PK ENCLOSED DESIGN BRAKES



Spring-Applied Motor Brakes, Captive Design

Parking and stopping standard brakes for outdoor applications

The PK (Very Thin) Enclosed range is a pre-assembled on/off dry safety electromagnetic brake. This safety brake is used for parking and emergency as well as some service braking. The AC motor is used in combination with the PK brake for regenerative braking of the truck. Various friction material are available from our standard to either a high friction coefficient for high torque or high energy material and powerful coil to optimize torque in a low profile package. The coil can be linked with a pulse width modulation power supply to reduce power consumption and maintenance.

The benefits of this cost competitive range include; one piece design for easy assembly, lower power consumption, longer battery life, and overall lower maintenance costs. The low profile design is particularly suitable for back to back dual drive configurations such as sit trucks and boom lifts.

- High torque within a compact space envelope
- Multi-step braking versions available
- Low profile space saving design
- Hand release on request
- IP67 on request

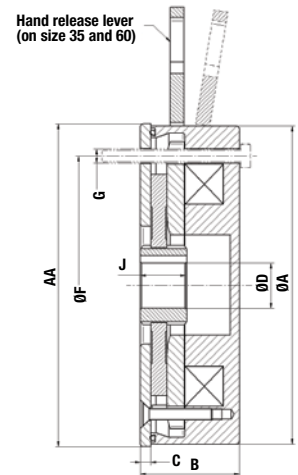
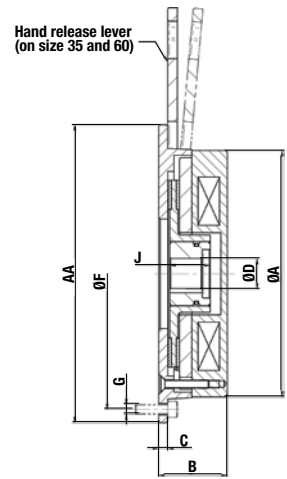

Size*	05 Captive	010 Captive	020 Captive	035 Captive	060 Captive
Static Torque (Nm)	9	21	38	50	165
Static Torque (lb. ft)*	6.6	15.5	28	37	122.1
A	91	109	138	153	168
B	41.5	42	43	43	67
C	–	4.6	–	5.6	–
D	10/12/15H7	15/20H7	10/15/20H7	19.05/20/25H7	20/25/30H7
J	18	20	20	25	45
F	72	90	112	168.3	152
G	3 × M4	3 × M5	3 × M6	4 × M6	3 × M8
AA	91	113	140	185	175
Hand Release	–	–	–	Available	Available
Ambient Temperature	Minus 20 Plus 60 Degree C				
Voltage	Pulse Width Modulation - based on customer requirements				

* Minimum torque over the life of a brake.

DUAL-STAGE PK BRAKES



Dual-Stage Spring-Applied Brakes

Two-step brake engagement prevents harsh dynamic

E-stop braking. Specific feature available on some designs of the PK series. (ISO6292 and ASTM B56.1 standards)

- Same mounting interfaces, shaft connection, and torque range as the standard PK brakes
- Dual-function, parking and emergency braking functionality
- Enhanced dual-voltage coil controlled via PWM (Pulse Width Modulation)
- Available with embedded control unit

As with the standard PK, various friction materials are available. The select material offers the perfect balance between static torque for parking and dynamic torque for service and emergency stopping over its life.

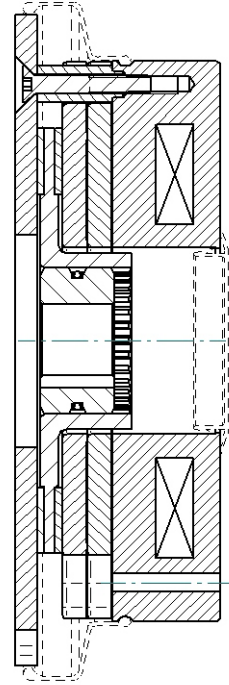

MULTIPLE CONTROL OPTIONS

The Dual-Stage PK brakes are compatible with most popular controllers.

However, the following Warner Electric controllers are recommended for optimum performance...

Standard ON/OFF controller

- The brake will engage in 2 separate steps from 0.2s to 1s (depending on the voltage suppressor implemented)
- The 1st step will provide 20 to 70% of the nominal brake torque (adjustable based on customer application)
- The 2nd step will provide the remaining torque to reach the nominal torque

Advanced controller

- The two steps can be controlled on demand.
- The controller will reduce the current until the first armature only drops: the first braking step.
- When power off, both stage 1 and 2 will engage.

FEATURES

Same features as the standard PK including a very high torque within a compact space envelope

- Smooth braking
- Two dependent braking stages
- Warner Electric controller on option

Please contact Warner Electric Europe for more information.

EDI BRAKES



Spring-Applied Dual-Disc Brakes

Parking and emergency braking functionality

INITIALLY DERIVATED FROM THE REKNOWN PK SERIES, the EDI range is a spring-applied electromagnetic safety brake specially designed for easy integration into in-line vehicle drivetrains. Those models utilize two friction discs for improved performance.

- High torque in reduced diameter - Torque 200Nm
- Special compact design allows the unit to fit in confined drivetrain space
- Dual voltage coil controlled via PWM (Pulse Width Modulation) provides long service life with reduced power consumption

As with the standard PK, various friction materials are available. The select material offers the perfect balance between static torque for parking and dynamic torque for service and emergency stopping over its life.

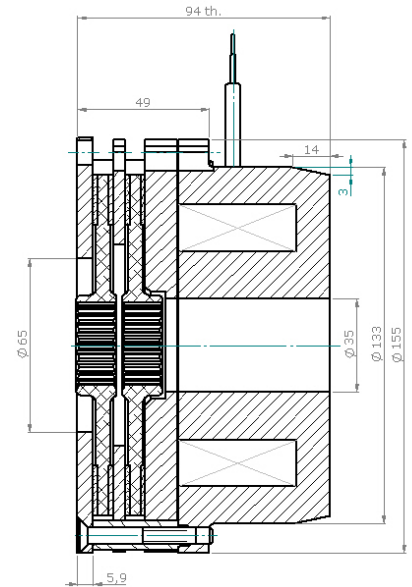

FEATURES

- One piece design for easy assembly
- Customized design to fit in the drivetrain
- High torque in reduced diameter (200nm)
- Single disc version also available
- Several friction material for electric vehicles
- Dual voltage coil for reduced power consumption
- Overall lower maintenance costs
- WES sensor available in option

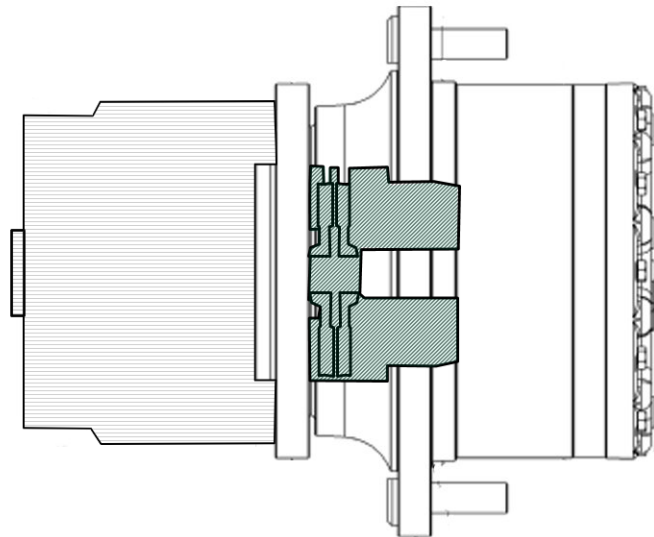

Please contact Warner Electric Europe for more information.

Forklift Truck & Electric Vehicle Braking Solutions

CBTB BRAKES



High Dissipating Motor Brakes

For Dual-Drive E-Vehicles

The CBTB family of electromagnetic axle brakes are specifically for use on electric-powered, dual-drive vehicles with capacities generally up to 8 tons (17,900 lbs.).

These advanced high-speed, high-torque brakes provide reliable emergency and parking brake functionality and allow for increased maximum vehicle speed and improved productivity.

The integration of proprietary non-stick friction material within a superior brake design ensures very high energy dissipation and low wear throughout the life of the vehicle.

The CBTB is designed for vehicles that require the narrowest foot print. It is installed between both wheel motors on the load bearing axle. When engaged, its double-disc arrangement allows the brake to act on both motors simultaneously.

An optional dual-stage functionality is available to provide better control of the torque by applying 50% or 100% of the brake torque capacity. It also prevents flat surface damage to tires that often occurs when wheels lock up during an abrupt emergency stop.

- High-torque, high-speed within a compact space envelope
- Proprietary dry friction material enables implementation of ElectroMagnetic brakes versus hydraulically-actuated and wet brake technologies, removing then the risk of oil leaks.
- Optional camshaft hand release lever is available

Exceptional Energy Capacity

The in-house W134 high energy, high speed and non-stick friction materials are fitted on all of the CBTB brakes.

For instance, a CBTB 170 is able to dissipate 18.1MJ total based on 700kJ Estops.

Model/Size		170	200	300
Rated Dynamic Torque	(Nm)	Up to 230 (2x115)	Up to 340 (2x170)	Up to 700 (2x350)
	(lb.ft.)	Up to 170 (2x85)	Up to 250 (2x125)	Up to 516 (2x258)
Operation Voltage (pull in / hold)	(Vdc)	24/6	24/6	24/12
Power (pull in / hold)	(Watts)	91/23	64/15	131/45
Outer Diameter	(mm)	215	245	332
Thickness	(mm)	102	102	116.3
Truck rated Capacity	(tons)	2.5 to 3.5	3.5 to 5	6 to 9
Spline type		DIN5480 N35x1.5x30x22-9H	DIN5480 N35x1.5x30x22-9H	DIN5480 N50x2x30x24 - 9H
Fixing Hole Requirements Size/Quantity/Location	(mm)	6xM6 IN PCD 196	6xM6 IN PCD 226	6xM8 IN PCD 304

AP BRAKES



Electromagnetic, Spring-Applied Brakes

Parking and emergency stop brakes

Very flat, low profile for limited space applications.

- Unique design with high torque in a comparatively slim package.
- IP 20 standard

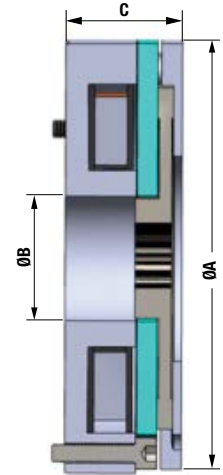

Model/Size			007	0020	0025	0030
Rated Dynamic Torque	(Nm)	*	7	20	25	30
	(lb.ft.)		5.0	15.0	18.5	22.0
Operating Voltage	(Vdc)	*	24			
Power	(Watts)	*	28.8			
Outer Diameter – ØA	(mm)	*	117			
Inner Diameter – ØB	(mm)	*	34			
Overall Length – C	(mm)	*	26.42			36
Fixing Hole Requirements Size/Quantity/Location	(mm)		3X M5 IN PCD 107			

* Features can be customized to suit specific application requirements.



Hand Release Lever version also available for this brake.

Forklift Truck & Electric Vehicle Braking Solutions

ERD-H BRAKES



SPECIAL DESIGN

Hydraulically Amplified, Electrically Released Brake

**Parking and stopping brake –
variable depending on load weight**

The ERD-H brake is a performance enhanced ERD safety brake. A hydraulic piston is integrated in the shell of the mast cylinder. The hydraulic force applied is proportional to the load on the fork. The spring force is defined for the truck unloaded and at full speed. By combining spring force and hydraulic force, you reach the optimal torque required for the specified deceleration rate and stopping distance. The torque applied increases as the weight of the load increases.

- Torque capacities 20 to 100 Nm
- For dry use
- For vertical and horizontal use
- Wear adjustment

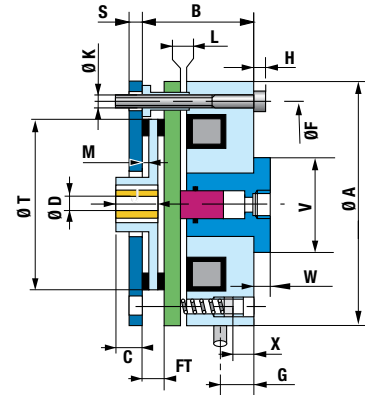

Size		020	035	060	100
Max. Combined Torque	[Nm]	20	35	60	100
Spring Torque	[Nm]	To be defined with the customer			
Hydraulic Torque	[Nm]	To be defined with the customer			
Max. Speed	[min-1]	3600			
Nom. Current At 20°C [24 VDC ± 30%]	A	1,22	1,61	1,94	2,35
A	[mm]	127	147	162	188
B	[mm]	47,5	54,5	64	71
C	[mm]	14,2	17	21	21
D	[mm]	15/20/22	20/24/25	25/30	25/30/35
F	[mm]	112	132	145	170
FT	[mm]	9,8	11	12	12
G	[mm]	15,5	19,7	19	22
H	[mm]	8	8	10	10
K	[mm]	3 × M6	3 × M6	3 × M8	3 × M8
L nominal	[mm]	0,4	0,4	0,5	0,6
M	[mm]	4	3	3	3
S Thick Flange	[mm]	9	9	11	11
S Inter. Flange	[mm]	4	5	5	6
T	[mm]	96	116	125	150
V On Flat	[mm]	50	50	50	50
W	[mm]	11	11	7	7
Inertia (Metal Only)	[kgcm ²]	2,8	7,4	21,7	36,5
Weight	[kg]	3,65	5,25	7,05	10,7
Max. Hydraulic Pressure	[Bar]	160			
Ambient Temperature	[°C]	-20 / +60			

SAE “BOLT-ON” BRAKES

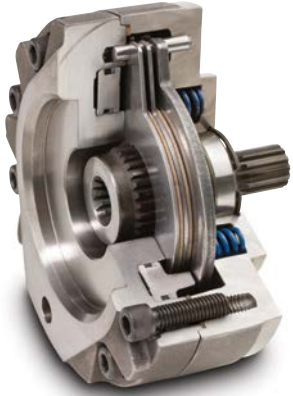

SPECIAL DESIGN

Hydraulic, Multi-Disc Brakes

Parking brakes

SAE multi-disc brakes are widely used in mobile equipment parking brake applications, especially in the event of a power loss where safety brake operation is essential.

- Static torque ranging from 50 to 1600 Nm (500 to 14,000 in. lbs.).
- Robust brake construction with high grade castings enables the brake to continuously hold 3,000 psi and 4,000 psi peak pressures
- Sealed construction keeps harmful contaminants out
- Spring applied hydraulic release operation ensures safety
- Bearing supported shaft ensures alignment for easy assembly
- Silicon chrome springs offer longer service life and high torque output
- SAE standard interface enables easy installation
- Advanced friction material provides improved all-round brake performance
- Close dynamic/static performance for smooth deceleration and E-stop when required
- Wet or dry options available
- Once installed, the brakes are fully sealed and can handle a variety of tough environments
- Cost effective solution, particularly for straight fixed axle vehicles
- Grade 12.9, 6-bolt connection for secure assembly

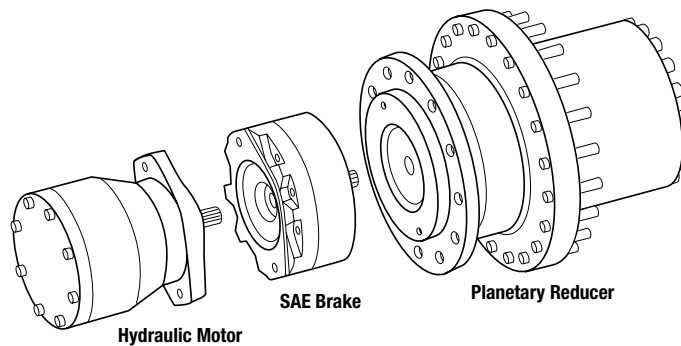

Matrix Brake Series	SAE Bolt-On Configuration	Rated Dry Static Torque Range		Rated Wet Static Torque Range		Full Release Pressure Range		Brake Unit Weight	
		lb.-in.	(Nm)	lb.-in.	(Nm)	psi	(Bars)	lb.	(kg)
AHBS	“A/B” Short	800-2,400	(90-270)	500-1,600	(56-180)	66-195	(4.6-13.4)	23	(10.4)
BHBS	“B” Short	800-2,400	(90-270)	500-1,600	(56-180)	66-195	(4.6-13.4)	21	(9.5)
AHB	“A/B”	1,000-3,600	(113-405)	1,000-2,400	(113-270)	66-195	(4.6-13.4)	27	(12.2)
BHB	“B”	1,000-3,600	(113-405)	1,000-2,400	(113-270)	66-195	(4.6-13.4)	25	(11.3)
CHB	“C”	4,000-10,000	(450-1130)	2,600-6,600	(290-945)	95-235	(6.5-16.2)	52	(23.6)
DHB	“D”	7,000-14,000	(790-1580)	4,600-9,300	(520-1050)	85-170	(5.9-11.7)	105	(47.6)

Forklift Truck & Electric Vehicle Braking Solutions

ELECTRONICS



Flexible Controller

To ease and enhance your brake integration

Turn your standard brake into a Smart brake with this embedded electronic controller.

Ideal for fleet management systems, particularly on AGV applications, this will give you access to the auto-diagnosis of your safety component.

Your brake becomes fully controlled and monitored when it is also equipped with the WES sensor (wear diagnosis).

- For single and dual stage brakes
- Plug and play integration
- Over-excitement control
- AEC-Q100 ready
- Accurate Control of the brake and IOT feature add on.
- PNP Inputs/Outputs
- CAN BUS ready
- Various versions: from 8VDC up to 400VAC
- IP67 rated

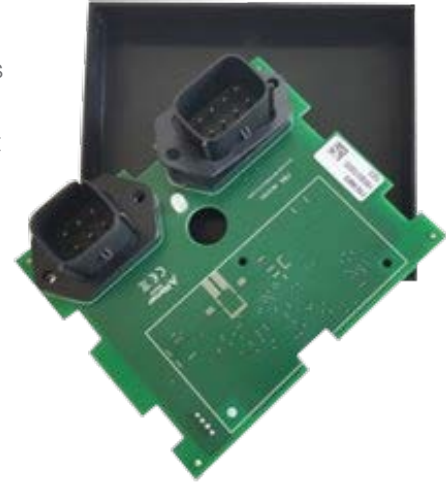

WES



Warner Electric Sensor (WES)

Contactless monitoring solution

The WES is a contactless monitoring solution, providing reliable detection of the smallest strokes, especially on spring applied brakes with noise damping systems. With no sensitive mechanical parts, it outmatches the electromechanical solutions by far regarding functional safety and lifecycle expectancy.

The WES features a temperature compensated sensor able to operate from -40°C up to 105°C. It offers 4 types of outputs. An NPN type (Version 1) with an integrated pull-up resistor that simplifies the integration in almost all PLC based installations, a highly isolated SSR relay type NC and NO outputs (Version 2 and 4) that provides backward compatibility with almost all dry contact switches of the market, and an optional analog ratiometric output (Version 3) which offers a real time wear detection that measures the brake air gap.

- Compact design
- Accurate sensing :
Hysteresis < 0.05 mm over the full range of temperature
- NPN output (integrated pull-up resistor)
- NO/NC electrical function compatible with standard mechanical μ -switches (depending on Voltage and Current)
- Analog output for wear sensor
- Operating temperature -40°C to 105°C



VERSION 1

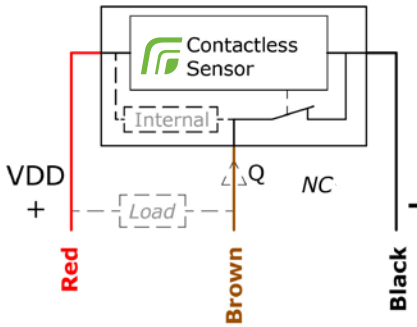

State Detection - NC

NPN Output (Sink) - 3 wires

Parameter	Symbol	Values			Note/Conditions
		Min	Typ	Max	
Supply Voltage	VDD	4 VDC	24 VDC	30 VDC	Reverse Voltage Protected
Supply Current				10 mA	
Operating Temperature		-40 °C		105 °C	
Output Voltage	Q	0.5 VDC	24 VDC	30 VDC	
Output Current	Q	< 1mA		30 mA	DC Current ESD protection to IEC 61000-4-2, level 4
Output Saturation Voltage				0.6 V	
Output Fall Time		50 μs			Depending on Load
Output Rise Time		50 μs			

VERSION 2

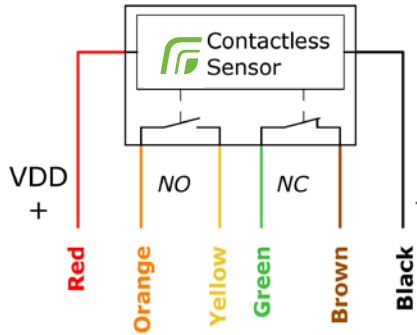

State Detection - NO/NCSSR

Outputs - 6 wires

Parameter	Symbol	Values			Note/Conditions
		Min	Typ	Max	
Supply Voltage	VDD	4 VDC	24 VDC	30 VDC	Reverse Voltage Protected
Supply Current	IDD			25 mA	
Operating Temperature		-40 °C		85 °C	
Output Voltage				60 VDC Peak	AC or DC allowed
Output LOAD Current				100 mA	AC or DC allowed
Output ON Resistance				16Ω	
Output OFF State Leakage Current				1 μA	
Output Fall Time				10 ms	VL = 10V
Output Rise Time				10 ms	

VERSION 3

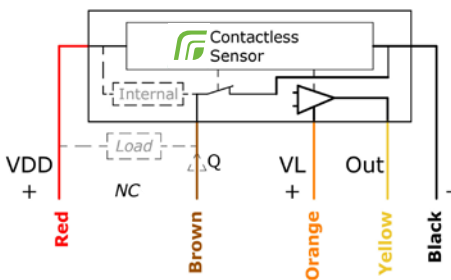

State Detection - NC + Brake Air Gap Measurement

NPN Output (Sink) - Analog Output - Ratiometric 5 VDC output - 5 wires

Parameter	Symbol	Values			Note/Conditions
		Min	Typ	Max	
Supply Voltage	VDD	4 VDC	24 VDC	30 VDC	Reverse Voltage Protected
Supply Voltage	VL	4.5 VDC	5 VDC	5.5 VDC	Reverse Voltage Protected
Supply Current				10 mA	
Operating Temperature		-40 °C		105 °C	
Output Voltage	Q	0.5 VDC	24 VDC	30 VDC	
Output Current	Q	< 1 mA		30 mA	DC Current ESD protection to IEC 61000-4-2, level 4
Output Voltage	Out	0.375 VDC	2.5 VDC	4.625 VDC	Out(Typ) = -S*Airgap(mm) + 2,5
Output Current	Out			1 mA	
Output Voltage Sensitivity	S	0.95 V/mm	1 V/mm	1.048 V/mm	

VERSION 4

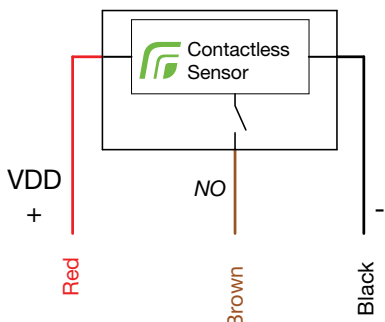

State Detection - NO

SSR Outputs - 3 wires

Parameter	Symbol	Values			Note/Conditions
		Min	Typ	Max	
Supply Voltage	VDD	4 VDC	24 VDC	30 VDC	Reverse Voltage Protected
Supply Current	IDD			25 mA	
Operating Temperature		-40 °C		85 °C	
Output Voltage				60 VDC Peak	AC or DC allowed
Output LOAD Current				100 mA	AC or DC allowed
Output ON Resistance				16Ω	
Output OFF State Leakage Current				1 μA	
Output Fall Time				10 ms	VL = 10V
Output Rise Time				10 ms	

Warner Electric Facilities

North America

USA

31 Industrial Park Road
New Hartford, CT 06057 - USA
860-379-1252

*Electromagnetic Clutches
and Brakes*

449 Gardner Street
South Beloit, IL 61080 - USA
815-389-3771

4578 East Park 30 Drive
Columbia City, IN 46725 - USA
260-244-6183

*Precision Electric Coils and
Electromagnetic Clutches and
Brakes*

Customer Service

1-800-825-6544

Application Support

1-800-825-9050

Europe

France

7 rue de Champfleür - CS20095
49182 St Barthelemy d'Anjou - France
+33 (0)2 41 21 24 24

*Electromagnetic Clutches
and Brakes*

Customer Service

+33 (0)2 41 21 24 76

Application Support

+33 (0) 2 41 21 24 24

Asia Pacific

Australia

+61 2 9894 0133

China

+86 21 5169-9255

Hong Kong

+852 2615 9313

Singapore

+65 6487 4464

Taiwan

+886 2 2577 8156

Thailand

+66 2322 5527



Scan to see all
the brands of
Regal Rexnord

Neither the accuracy nor completeness of the information contained in this publication is guaranteed by the company and may be subject to change in its sole discretion. The operating and performance characteristics of these products may vary depending on the application, installation, operating conditions and environmental factors. The company's terms and conditions of sale can be viewed at <http://www.altramotion.com/terms-and-conditions/sales-terms-and-conditions>. These terms and conditions apply to any person who may buy, acquire or use a product referred to herein, including any person who buys from a licensed distributor of these branded products.

©2023 by Warner Electric LLC. All rights reserved. All trademarks in this publication are the sole and exclusive property of Warner Electric LLC or one of its affiliated companies.