

Electric Brake Solutions for Electric Equipment Applications

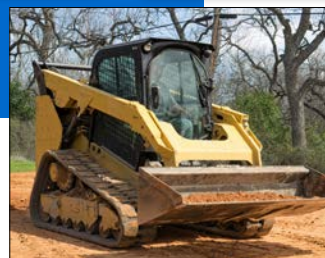
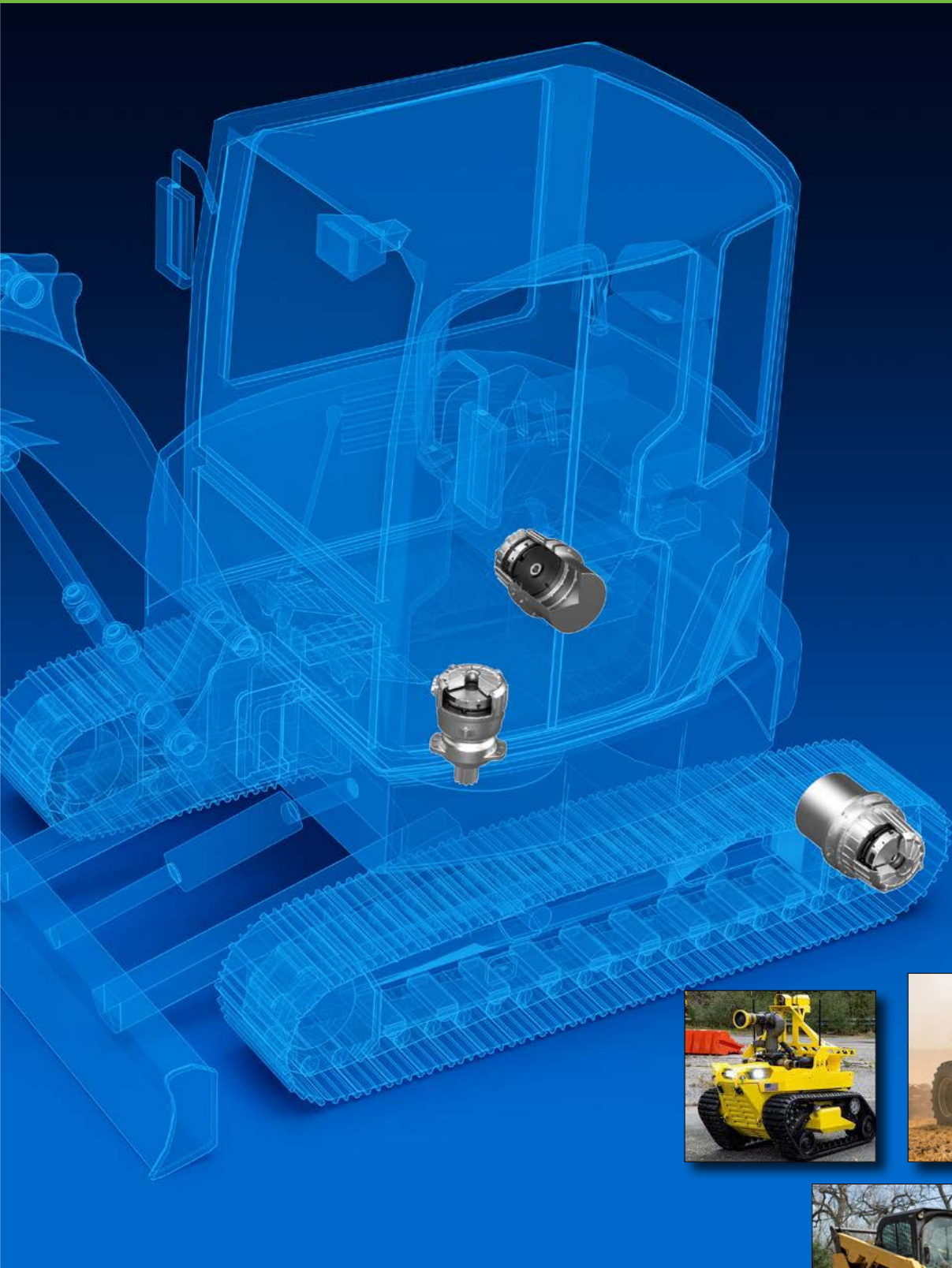

WARNER ELECTRIC BRAKE SOLUTIONS PROVIDE RELIABLE PERFORMANCE ON BATTERY-POWERED EQUIPMENT

The rapidly growing demand for compact, battery-powered construction and agriculture equipment has created a highly competitive market environment for OEMs. Warner Electric, a global leader in electromagnetic brake technologies, is uniquely positioned to support equipment design engineers as they meet these application challenges.

Reduced power consumption for increased operating time

Warner Electric offers innovative braking solutions designed to reduce power consumption on a wide variety of motions for battery-powered construction equipment, including electric swing drives and electric track drives for loaders, dozers, and excavators, traction wheel motors on compact skid steers, wheeled excavators, dump vehicles and mobile elevating work platforms (MEWPs). Warner braking technologies are also ideal for many agriculture applications, including autonomous machines and small electrically driven equipment.

Highly experienced Warner Electric application engineers routinely work with OEM engineering teams to develop compact, energy efficient braking solutions to meet the requirements for specific equipment, whether it's for a completely new equipment design or the electric conversion of existing equipment.

Standard product or custom solutions

Utilizing existing, proven braking solutions, Warner engineers can quickly modify a standard brake design and ship prototypes to OEMs for testing. Warner Electric's ability to rapidly respond to a customer need saves valuable time and effort for busy OEM engineers while allowing them to focus on other critical equipment systems and components.

Whether a modified standard product or a completely new custom system solution is required, Warner Electric provides complete sales and engineering support to customers around the world, from the very first concept to the detailed planning, design variation phase and commissioning.

Global manufacturing footprint

With manufacturing facilities strategically positioned around the world, Warner Electric can provide short lead times while meeting the demanding delivery requirements of global OEM production schedules.

Braking solutions for all types of drive configurations

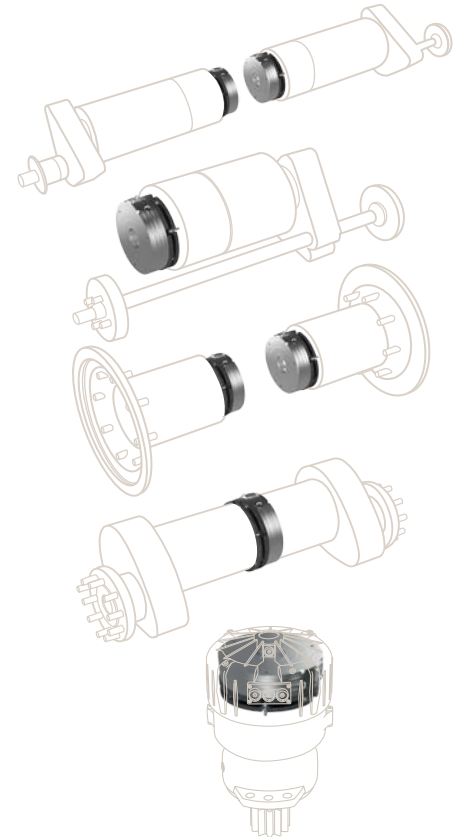

ADVANCED BRAKING TECHNOLOGIES FOR ELECTRIC EQUIPMENT



Very thin, powerful and proven brake design

The Original PK Brake... High torque in a compact space envelope

The Very Thin (PK) range is a pre-assembled on/off dry spring-applied electromagnetic brake. This brake is used for parking and emergency as well as some service braking.



Compact static brake, thin and modular

Catalogue and thickness adaptive design for easy and flexible integration with parking brake functionality

WR and other brake ranges are pre-assembled spring-applied, dry power-off electromagnetic brake. Models are highly reliable and compact for static engagement.



High dissipating motor brake

For dual drive E-vehicles with up to 8 tons (17,900 lbs.) capacity

CBTB advanced high-speed, high-torque brakes provide reliable emergency and parking brake functionality and allow for increased maximum equipment speed and improved productivity.

Electric Construction Equipment

- Excavators
- Wheeled & Tracked Loaders
- Dump Trucks
- Tracked Lifts
- Asphalt Pavers

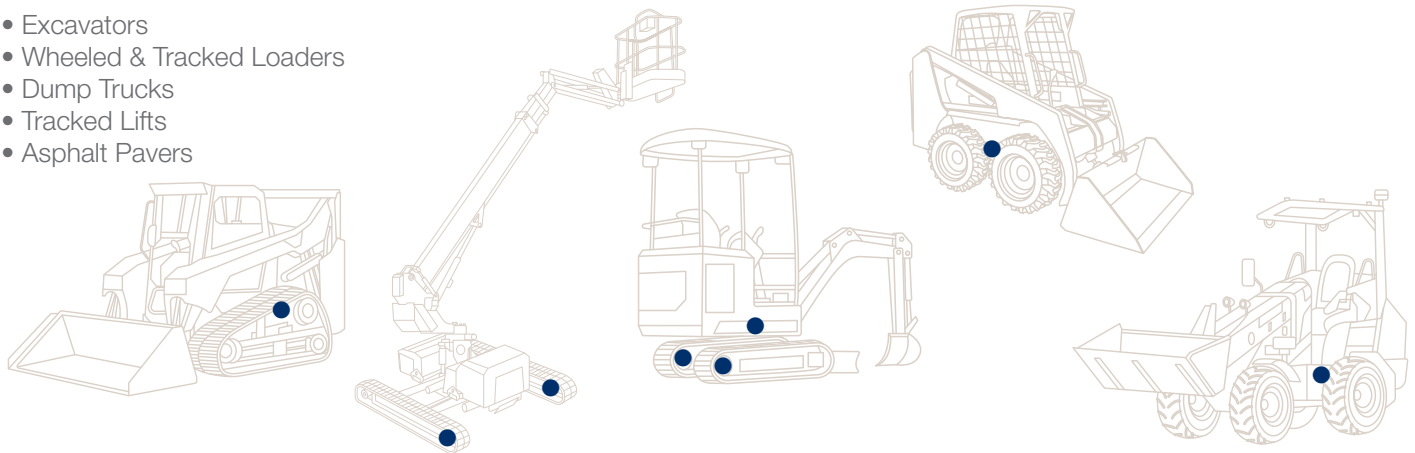

Electric Ag Equipment

- Sprayers
- Livestock Feeders
- Autonomous Machines
- Ag Robots

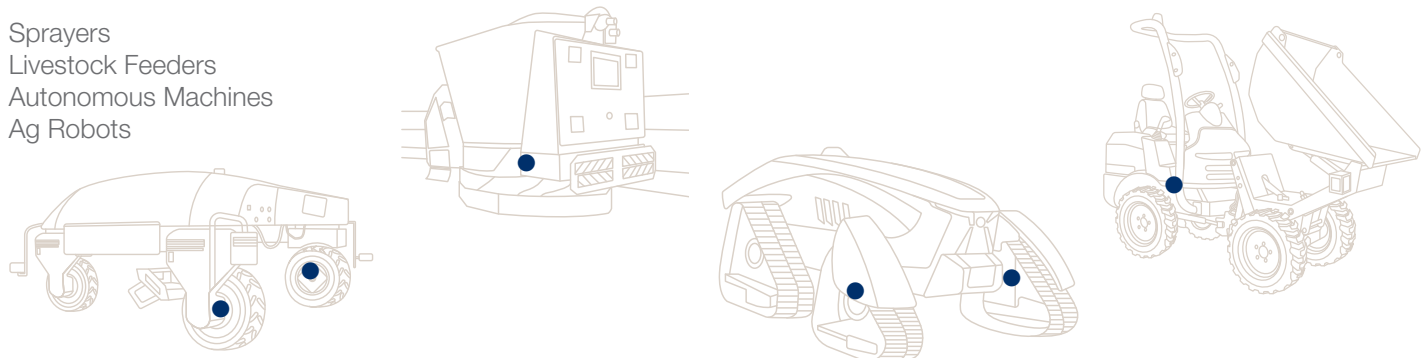

Other Electric Equipment

- Robots (Firefighting, Surveillance, etc.)
- Shuttle buses
- Road Sweepers
- Weed Killing Vehicles

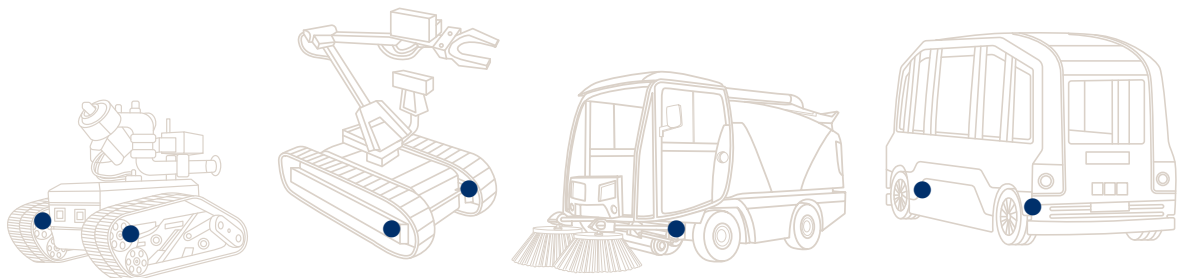

Convert a standard brake into a smart brake

Flexible embedded controller features plug & play integration

Ideal for fleet management systems, particularly on EV applications, provides access to the auto-diagnosis brake component.



Accurate sensing in a compact design

The WES **contactless monitoring** solution provides reliable detection of the smallest strokes, especially on spring-applied brakes. Units also feature real time wear detection. Made without sensitive mechanical parts, it greatly outperforms electromechanical solutions in functional safety and lifecycle expectancy high power density.



Enhance performance with advanced friction materials

Regal Rexnord engineers have developed a proprietary **NON-STICK** friction material specifically designed for cold room and outdoor environments with high moisture levels and wide temperature differentials.

Warner Electric Facilities

North America

USA

31 Industrial Park Road
New Hartford, CT 06057 - USA
860-379-1252

*Electromagnetic Clutches
and Brakes*

449 Gardner Street
South Beloit, IL 61080 - USA
815-389-3771

4578 East Park 30 Drive
Columbia City, IN 46725 - USA
260-244-6183

*Precision Electric Coils and
Electromagnetic Clutches and
Brakes*

Customer Service

1-800-825-6544

Application Support

1-800-825-9050

Europe

France

7 rue de Champfleür - CS20095
49182 St Barthelemy d'Anjou - France
+33 (0)2 41 21 24 24

*Electromagnetic Clutches
and Brakes*

Customer Service

+33 (0)2 41 21 24 76

Application Support

+33 (0) 2 41 21 24 24

Asia Pacific

Australia

+61 2 9894 0133

China

+86 21 5169-9255

Hong Kong

+852 2615 9313

Singapore

+65 6487 4464

Taiwan

+886 2 2577 8156

Thailand

+66 2322 5527



Scan to see all
the brands of
Regal Rexnord

Neither the accuracy nor completeness of the information contained in this publication is guaranteed by the company and may be subject to change in its sole discretion. The operating and performance characteristics of these products may vary depending on the application, installation, operating conditions and environmental factors. The company's terms and conditions of sale can be viewed at <http://www.altramotion.com/terms-and-conditions/sales-terms-and-conditions>. These terms and conditions apply to any person who may buy, acquire or use a product referred to herein, including any person who buys from a licensed distributor of these branded products.

©2023 by Warner Electric LLC. All rights reserved. All trademarks in this publication are the sole and exclusive property of Warner Electric LLC or one of its affiliated companies.