

ARC Magnetic Capping Headsets

Service & Installation Instructions

P-2016-WE
ARC



 **Warner**[®]
Electric
An **Altra Industrial Motion** Company

ARC Installation Procedure

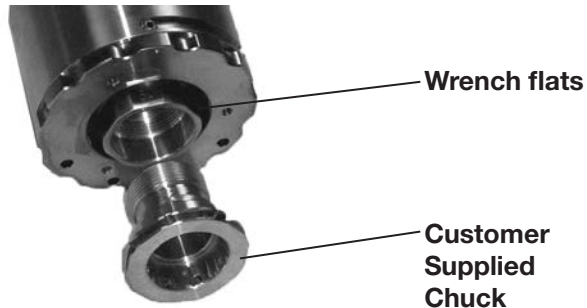

Figure 1

Install chuck (not supplied). Use appropriate open-end wrench (**YTL4-0009** or **YTL4-0007**) depending on headset model to hold headset output. See Figure 1.

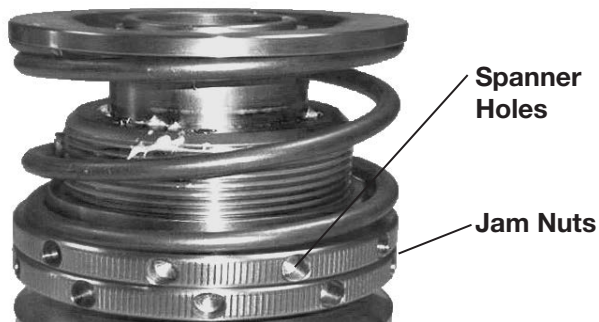

Figure 2

Set the top-load assembly using provided spring setting chart. Lock the jam nuts using O.D. spanner wrench (**YTL3-0009**). See Figure 2.

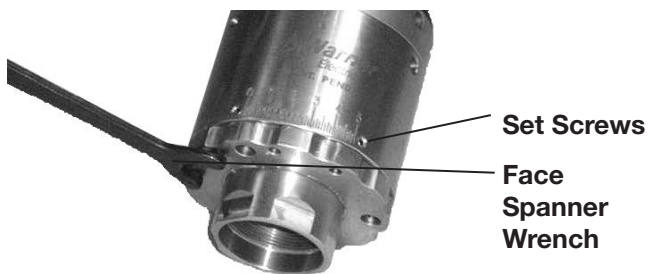

Figure 3

Set the preliminary static torque using provided torque setting chart. Loosen set screws with hex key wrench, turn end cap with face spanner wrench (**YTL2-0002**), tighten set screws to 8-10 lb-in. Over tightening is not necessary and will strip the screws or possibly damage the housing body. See Figure 3.

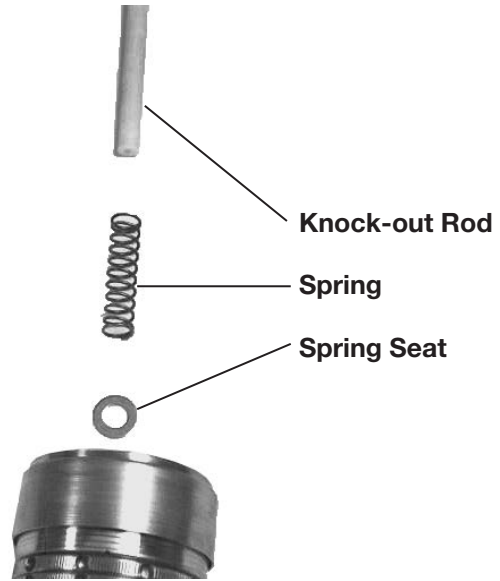

Figure 4

Apply anti-seize compound to spindle shaft. Install spring seat and spring (not supplied) if required. See Figure 4.

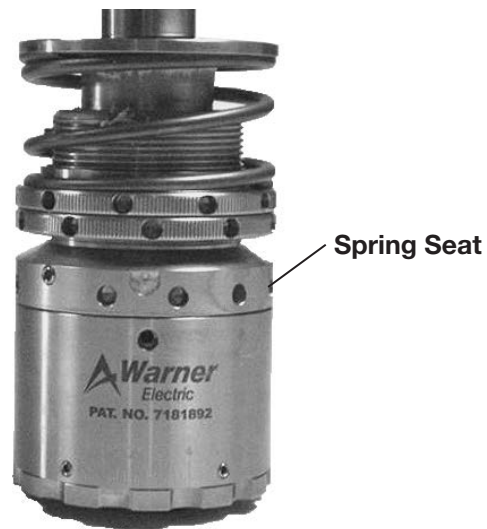

Figure 5

Install headset on spindle. Turn onto threaded spindle until headset is fully seated on spindle. Tighten headset securely using O.D. Spanner wrench (**YTL3-0009**). See Figure 5.

Setting Top Load Spring Force

1. Determine initial spring setting from spring force chart below.
2. Compress the spring with the locking ring just enough to allow the adjustment ring into its correct setting.
3. Move the adjustment ring to the desired setting. Bring the locking ring down and jam the rings together with a spanner wrench.
4. For optimum results check download force with a force scale.
5. Set headset on the scale and manually compress the spring downward 5mm. Take the force reading at this position. The lines on the spring cover are .100" (2.5mm) apart, so two lines equal the recommended .200" (5mm) compression.

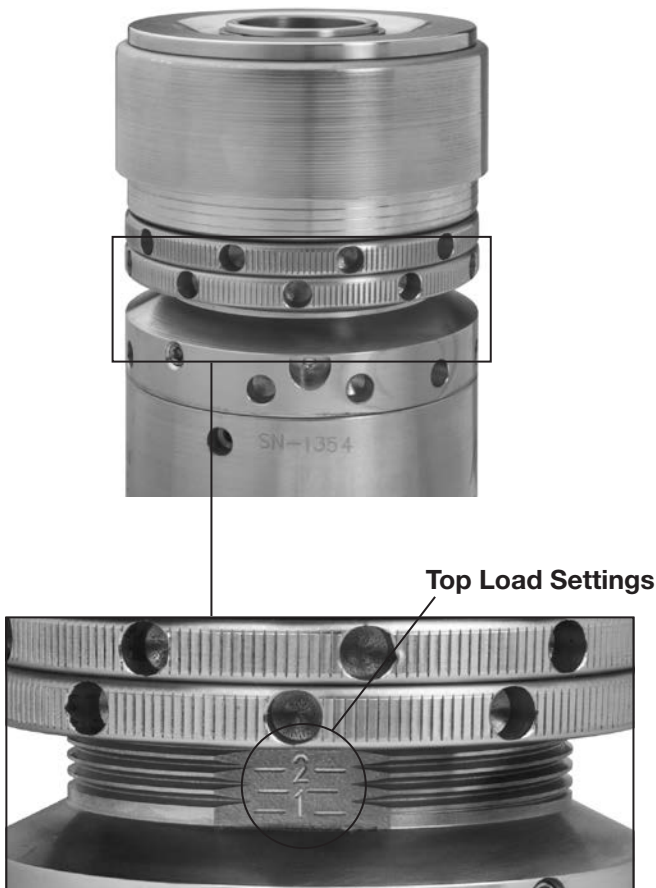

Figure 6

Top Load Spring Force Setting Chart

Spring Force at 0.200" (5mm) Deflection

Spring Setting	Standard Spring YTP1-0010 Plain		Low Spring YTP1-0003 Grey		High Spring YTP1-0008 Black	
	lb	Kg	lb	Kg	lb	Kg
1.0	34	15	24	11	50	23
1.5	39	18	27	12	58	26
2.0	44	20	31	14	66	30
2.5	49	22	34	15	73	33
Max	54	24	38	17	80	37

Spring Force at 0.100" (2.5mm) Deflection

Spring Setting	Standard Spring YTP1-0010 Plain		Low Spring YTP1-0003 Grey		High Spring YTP1-0008 Black	
	lb	Kg	lb	Kg	lb	Kg
1.0	29	13	20	9	43	20
1.5	34	15	24	11	50	23
2.0	39	18	27	12	58	26
2.5	44	20	31	14	66	30
Max	49	22	34	15	73	33

NOTE: The charts above provide actual spring loads without any added load due to the weight of the headset. These spring loads are valid for any headset. Not all headsets have the full range of settings; some headsets do not have a '3.0' setting, other headsets do not have '1.0' or '1.5' settings. The spring loads are calculated at the given deflection as listed in the chart.

Setting Application Torque

1. Determine initial clutch setting from torque chart below.
2. Loosen the torque adjustment screws. Rotate the adjustment ring using the face spanner wrench to the desired setting and then retighten the torque adjustment screws. Do not use the set screw in the slot on the backside of the housing for torque adjustment. Tighten set screws to 8-10 lb-in. Over tightening is not necessary and will strip the screws or possibly damage the housing body.
3. For optimum results, check setting with a torque wrench and FIX-0007 or FIX-0010.



Figure 7

Application Torque Setting Charts

Clutch Setting	Application Torque-Low Inertia Magnet		Application Torque (Ncm) Standard Magnet	
	lb-in	Ncm	lb-in	Ncm
0.00	2.00	22.5	2.5	28.2
0.50	3.50	39.5	4.0	45.2
1.00	5.00	56.5	5.0	56.5
1.50	8.50	96.0	8.5	96.0
2.00	10.50	118.6	11.0	124.3
2.50	13.50	152.5	15.0	169.5
3.00	16.00	180.7	18.5	209.0
3.50	17.50	197.7	22.0	248.5
4.00	18.50	209.0	24.0	271.1
4.50	19.00	214.6	25.5	288.1
5.00	19.50	220.3	26.0	293.7

Recommended Maintenance Schedule

Lubricate the upper assembly every 500 hours of run time.

- Using a grease injector needle, apply lubricant into the grease port.
- Recommended grease: No. 2 Food Grade Grease



Figure 8

Disassemble, clean, and replace all wearing parts in the headset every 7000 hours of machine run time.

- See rebuild instructions for detailed information on disassembly and assembly of Warner headsets.
- Dependent upon machine speed and washdown procedure, some environments may require more frequent rebuilds.

Rebuild Kits available:

- **M4.5-BK** (Bearing and Hardware Rebuild Kit)
- **M4.5-MK** (Magnet Rebuild Kit)
- **M4.5-PK** (Push rod Rebuild Kit)
- **M4.5-TL** (Replacement Top Load Assembly)

*Contact customer service for the exact kit part number for your specific headset model.

Installation Tools and Fixtures



Figure 10

FIX-0001 – Bearing installation and removal fixture for the ZRC style bearings.



Figure 11

FIX-0002 – Bearing installation and removal fixture for the ARC style bearing.

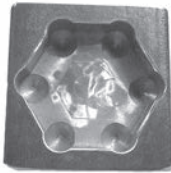

Figure 12

FIX-0003 – Use to hold the output of ARC style unit during disassembly. Earlier revision levels with a larger output dimension that will not fit in this fixture can be clamped directly in a vice.



Figure 13

FIX-0004 – Upper assembly nut removal fixture for ZRC style unit.

Continued on page 6.

Tool Kit Component Parts Cont.



Figure 14

FIX-0019 – Clutch nut removal fixture for some ZRC style units. Not included in tool kits. May be ordered on an as-needed basis.



Figure 15

FIX-0005 – Upper assembly nut removal fixture for ARC style unit.



Figure 16

FIX-0007 – Torque checking fixture for some ARC models.



Figure 17

FIX-0010 – Torque checking fixture for some ARC & ZRC models.



Figure 18

YTL3-0009 (Qty 2) & YTL3-0008 – Adjustable O.D. Spanner Wrenches used for adjusting top load and separating top load and clutch body.



Figure 19

YTL4-0009, YTL4-0005, YTL4-0008, YTL4-0010, YTL4-0007 – Open end wrenches used to install and remove chucks on several ARC & ZRC models.



Figure 20

YTL2-0002 – Face Spanner Wrench for adjusting end cap and setting static torque on ARC & ZRC units.



Figure 21

YTL3-0005 – ER-25 Spanner Wrench used for upper assembly adapter removal for some ZRC style units.

ARC Clutch Rebuild Procedure



Figure 22

Remove set screw between clutch and top load assembly using a 1/8" 3mm hex wrench. See Figure 22.



Figure 23

Separate top load assembly from clutch using two spanner wrenches (YTL3-0009) and soft hammer. Sometimes a steel hammer may be required to loosen this joint. See Figure 23.



Figure 24

Remove two set screws using a 3/32" 3mm hex wrench. Remove third set screw in the slot on the backside of the housing. See Figure 24.



Figure 25

Remove three socket head cap screws using a 9/64" 3mm hex wrench. See Figure 25.

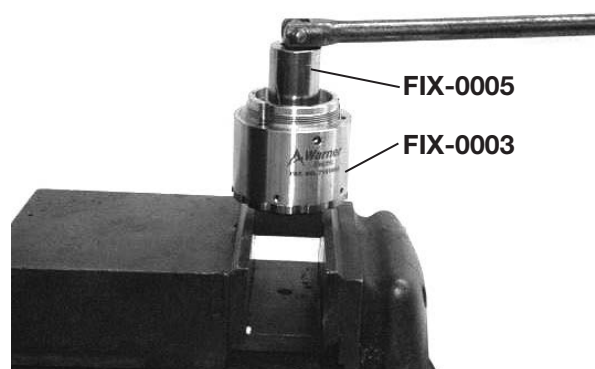

Figure 26

Place FIX-0003 in a vice. Place clutch in the fixture and put FIX-0005 on top. Loosen nut and lift off housing. See Figure 26.



Figure 27

Remove seal and bearing from housing. See Figure 27.



Figure 28

Remove seal and bearing from housing. See Figure 28.



Figure 29

Press bearing out of housing using FIX-0002 and an arbor press. See Figure 29.

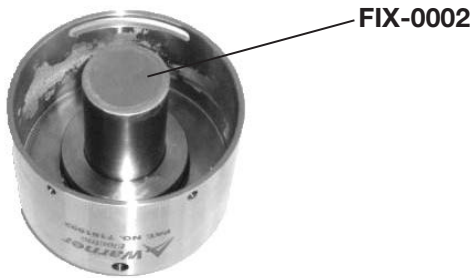

Figure 30

Turn housing over. Press new bearing in housing using FIX-0002 and an arbor press. See Figure 30.



Figure 31

Put in new seal. See Figure 31.



Figure 32

Separate magnet stack and clean all magnets – replace as required. Use an alcohol based cleaning solvent to clean the black driver magnets. Do not use anything abrasive when wiping the black driver magnets. Use a Scotch Brite deburr wheel to polish the hysteresis magnet. See Figure 32.



Figure 33

To replace the magnet on end cap, break the magnet with a hammer. Remove broken magnet pieces and old screws. Install new magnet and new screws. Epoxy magnet holes with epoxy packet from rebuild kit. Make sure epoxy does not build up on surface of magnet more than .010" (0.25mm). See epoxy instructions below (Figure 34)



Figure 34



Figure 35

Install magnet plate into housing. Line up any three holes and insert screws. See Figure 35.



Figure 36

Tighten the three socket head cap screws with a 9/64" 3mm hex wrench. See Figure 36



Figure 37

Insert shaft into housing. See Figure 37.



Figure 38

Apply a thin layer of grease to the driver magnet. See Figure 38.



Figure 39

Install spacer. See Figure 39.



Figure 40

Install hysteresis magnet. Align on shaft and allow it to drop carefully down to the spacer. Use caution as magnets will attract to each other. See Figure 40.



Figure 41

Apply a thin layer of grease to the adjustable end cap driver magnet. See Figure 41.

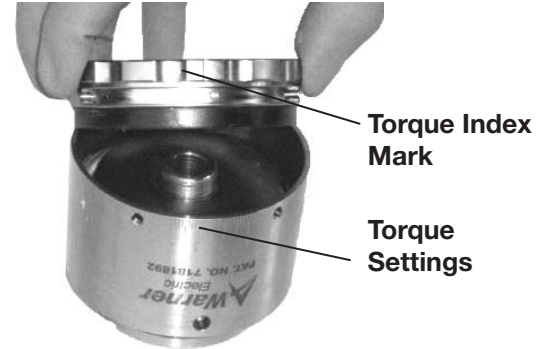

Figure 42

With torque settings on the housing and torque index mark on end cap facing you - place housing on end cap. Use caution as magnets will attract to each other. Tap in place with soft hammer if necessary. See Figure 42.

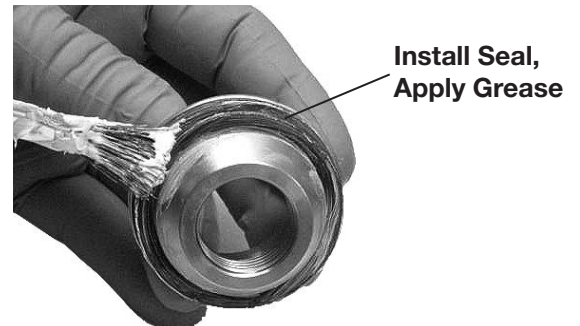

Figure 43

**On newer models install seal and apply a thin layer of grease to top of seal. If your end cap does not have a groove in it to accept the seal, skip this step. See Figure 43.

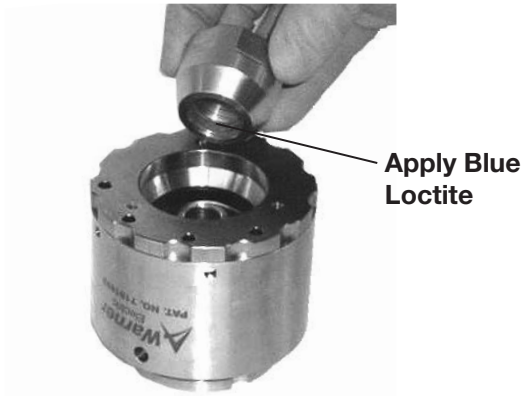

Figure 44

Apply a small amount of blue loctite (242 threadlocker) on the inner thread of the nut; screw into place. See Figure 44.

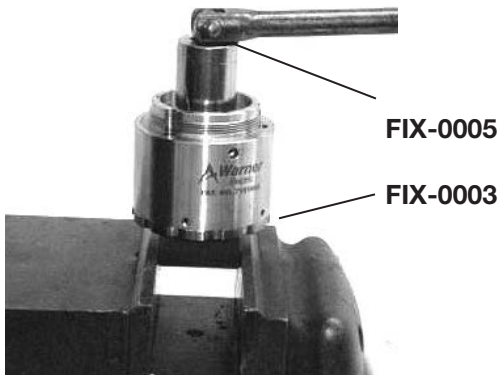

Figure 45

Using FIX-0003 and FIX-0005 to hold the clutch in place, torque to 45 ft-lbs. (508Ncm). See Figure 45.



Figure 46

Install .472" (12mm) long set screw. See Figure 46.



Figure 47

Install two 1/4" (M6) set screws. See Figure 47.



Figure 48

Apply grease to top of seal. See Figure 48.



Figure 49

Torque test the unit before re-installing upper assembly and installing headset on machine. Using 1" face spanner wrench (YTL2-0002) to set the torque at setting 5. See Figure 49.

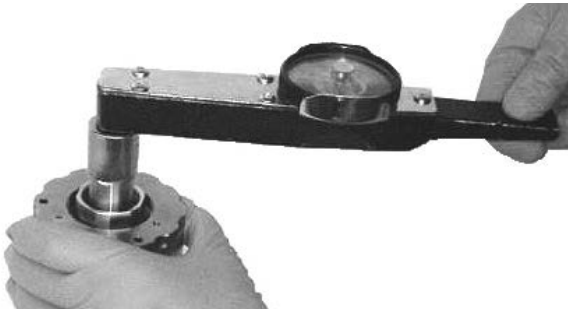

Figure 50

Using FIX-0007 or FIX-0010 and a torque wrench, check to make sure the torque is smooth and reaching the specified maximum torque. If torque is not smooth or is very high, disassemble clutch to look for mechanical rubbing or parts assembled incorrectly. Check the epoxy over the magnet screws for signs of rubbing. If the epoxy is rubbing, carefully trim the epoxy down to specification. See Figure 50



Figure 51

Set torque to desired setting using face spanner wrench (YTL2-0002) and tighten set screws. See Figure 51. Tighten set screws to 8-10 lb-in. Over tightening is not necessary and will strip the screws or possibly damage the housing body.

ARC Top Load Rebuild Procedure



Figure 52

Using a small standard screwdriver remove snap ring. See Figure 52.



Figure 53

Remove spring plate, upper spring cover (if applicable), spring, and lower spring cover (if applicable) from top-load assembly. See Figure 53.



Figure 54

Remove internal shaft and inspect for wear, replace as necessary. Clean all parts. See Figure 54.



Figure 55

Install new pins, apply a thin layer of grease to internal shaft and pins. See Figure 55.



Figure 56

Remove seal and replace. See Figure 56.



Figure 57

Apply a thin layer of grease the seal and bore. See Figure 57



Figure 58

Install shaft in top load assembly. Make sure all 4 pins stay engaged during insertion. See Figure 58.



Figure 59

Set top-load on FIX-0002 so that the shaft does not push in while compressing the spring. Install lower spring cover (if applicable), spring, upper spring cover (if applicable), and spring plate. See Figure 59.



Figure 60

Compress spring plate and install snap ring. Make sure that the snap ring seats fully into groove. See Figure 60.



Figure 61

Thread together the clutch and top-load assembly. See Figure 61.



Figure 62

Tighten using spanner wrenches (YTL3-0009) and a soft hammer. See Figure 62.



Figure 63

Install set screw with 1/8" 3mm hex wrench; tighten. See Figure 63.

Rebuild Kits and Rebuild Exchange Programs

Warner Electric Capping Headsets

Magnetic Headset Rebuild Kits

End-users can purchase rebuild kits to rebuild the magnetic headsets themselves. It is recommended that the end-user keep both bearing and magnetic kits on hand in order to reduce maintenance downtime.

Factory Rebuild Program

End-users can ship their headsets back to Warner Electric for a full factory rebuild and certification. Upon receipt, Warner Electric will rebuild and factory certify headsets. Typical turnaround for headsets is 1-2 weeks. Expedited services are available upon request. Additional fees will apply. End-user will be invoiced for the rebuilt headset when the rebuilt headset is shipped. The end-user is responsible for freight to and from factory.

Headset Exchange Program (TWO YEAR AGREEMENT):

Once end-users own Warner Electric headsets, they have the option of signing up for a Warner Electric Headset Exchange Program for rebuilt headsets. In this case, end-users would receive rebuilt headsets from Warner Electric at a predetermined time during the year in exchange for their used Warner Electric headsets. End-user signs an agreement for the headset exchange program for 2 years. Pricing for the headset exchange program will be paid once per year, on the date the agreement is signed and on the agreement anniversary date. At the beginning of the agreement period, the end-user must specify the headset model, how many heads are to be rebuilt, and what time(s) during the year rebuilt headsets are expected. Warner Electric will ship rebuilt headsets to end-user at the predetermined date. Within two weeks from receipt of rebuilt headsets, the end-user is required to return their used headsets. The end-user is responsible for freight to and from the factory.

Headset Lease Exchange Program (3 YEAR AGREEMENT)

Warner Electric offers an option for end-users to receive factory rebuilt Warner Electric headsets at no initial purchase fee if they sign up for a 3 year headset exchange program with Warner Electric. At the end of the 3 year agreement period, the end-user will own their Warner Electric headsets.

End-user signs an agreement for the headset exchange program for 3 years. Pricing for the headset exchange program will be paid once per year, on the date the agreement is signed and on the agreement anniversary dates. At the beginning of the agreement period, the end-user must specify the headset model, how many heads are to be rebuilt and what time(s) during the year rebuilt headsets are expected. Upon receipt of initial payment, Warner Electric will ship rebuilt headsets to the end-user. On the predetermined rebuild dates, Warner Electric will ship rebuilt headsets to end-user. Within two weeks from receipt of rebuilt headsets, the end-user is required to return their used headsets. At the end of the 3 year agreement period, the end-user will own their magnetic headsets. The end-user is responsible for all freight to and from the factory.

On-site Service Support

Warner Electric Capping Headsets

On-site service support is available for installation of new Warner headsets, rebuild support of existing Warner headsets, training, etc. Our factory-trained and certified service department with over 50 years combined experience can help prevent costly delays and down time of your capping operation.

Precision Tork is the ONLY Service Group that is factory authorized to work on the Warner Electric headsets.

Services Provided:

- Installation of new equipment
- Machine audits and troubleshooting
- Service and repair of filling and capping equipment
- Consulting: New Installations-existing issues for filling and capping
- Develop new design for efficient production
- Assist with planning of preventative maintenance programs
- Operator and mechanical training
- Highly qualified trained field engineers ready to work on the following bottling equipment:

Precision Tork Service Benefits:

- We manufacture the headsets!
- Most up-to-date designs available only through Precision Tork.
- Our service technicians are trained to rebuild your headsets to their existing revision level OR upgrade them to the latest technology.

- Component parts and rebuild kits on hand so you do not incur downtime.
- Coming soon...secure website for headset information and parts ordering with a credit card.

To schedule a certified Warner Service Technician contact Melissa Bottke at 1-888-350-1891

Upgrade Kits

Warner Electric Capping Headsets

Benefits of upgrading your M4.5 Headsets:

1. Eliminate setscrew stripping during torque adjustment
 - Larger adjustment screws in housing makes it easier to adjust the torque and helps prevent stripping of the screw head. Old setscrew in a 10-32 utilizing a 3/32" wrench. The new setscrew is a 1/4-28 utilizing a larger 1/8" wrench.
2. Longer bearing and magnet life
 - Bottom seal in end cap helps to prevent water and other contaminants from getting inside of the headset. Easy to retrofit in the field.

Here's how to order:

1. Find the headset part number or serial number engraved on the housing body.
2. Call 1-888-350-1891
3. See Cross-reference list below for part number Information.
4. Parts are in stock and ready for immediate delivery.
5. Step-by-step instructions available.

Material Requirements

Anti-Seize Compound

- Apply to spindle at time of headset installation

Cleaning Solution

- Alcohol based cleaning solvent used to wipe and clean parts during rebuild.

Grease

- Citgo Clarion Food Grade Grease, HTEP NLGI No. 2 Grade used to lubricate headset.

Loctite

- Blue Removable - 242 threadlocker used to secure components within the headset.

Epoxy

- Five minute epoxy – Amber, Devcon dev-pak adhesive 14270 used to fill counter-bores in the magnet plate.

Information for Ordering Spare Parts

It is important to stock spare parts on hand to avoid unnecessary downtime. Warner recommends that you stock at least two spare headsets per machine and a few bearing and magnet rebuild kits so that you have the necessary parts on hand if you need them.

How to order spare parts – required information:

1. Purchase Order Number.
2. Warner headset model number/part number OR serial number (only on models manufactured July 2007 and later).
3. Warner Component or Kit Part Number.
4. Preferred distributor to order from. All orders will be routed through local distribution. Pricing and lead time can be quoted by calling the Manufacturing Facility at (888) 350-1891.

Warranty

Warner Electric LLC warrants that it will repair or replace (whichever it deems advisable) any product manufactured and sold by it which proves to be defective in material or workmanship within a period of one (1) year from the date of original purchase for consumer, commercial or industrial use.

This warranty extends only to the original purchaser and is not transferable or assignable without Warner Electric LLC's prior consent.

Warranty service can be obtained in the U.S.A. by returning any defective product, transportation charges prepaid, to the appropriate Warner Electric LLC factory. Additional warranty information may be obtained by writing the Customer Satisfaction Department, Warner Electric LLC, 449 Gardner Street, South Beloit, Illinois 61080, or by calling 815-389-3771.

A purchase receipt or other proof of original purchase will be required before warranty service is rendered. If found defective under the terms of this warranty, repair or replacement will be made, without charge, together with a refund for transportation costs. If found not to be defective, you will be notified and, with your consent, the item will be repaired or replaced and returned to you at your expense.

This warranty covers normal use and does not cover damage or defect which results from alteration, accident, neglect, or improper installation, operation, or maintenance.

Some states do not allow limitation on how long an implied warranty lasts, so the above limitation may not apply to you.

Warner Electric LLC's obligation under this warranty is limited to the repair or replacement of the defective product and in no event shall Warner Electric LLC be liable for consequential, indirect, or incidental damages of any kind incurred by reason of the manufacture, sale or use of any defective product. Warner Electric LLC neither assumes nor authorizes any other person to give any other warranty or to assume any other obligation or liability on its behalf.

WITH RESPECT TO CONSUMER USE OF THE PRODUCT, ANY IMPLIED WARRANTIES WHICH THE CONSUMER MAY HAVE ARE LIMITED IN DURATION TO ONE YEAR FROM THE DATE OF ORIGINAL CONSUMER PURCHASE. WITH RESPECT TO COMMERCIAL AND INDUSTRIAL USES OF THE PRODUCT, THE FOREGOING WARRANTY IS IN LIEU OF AND EXCLUDES ALL OTHER WARRANTIES, WHETHER EXPRESSED OR IMPLIED BY OPERATION OF LAW OR OTHERWISE, INCLUDING, BUT NOT LIMITED TO, ANY IMPLIED WARRANTIES OF MERCHANTABILITY OR FITNESS.

Some states do not allow the exclusion or limitation of incidental or consequential damages, so the above limitation or exclusion may not apply to you. This warranty gives you specific legal rights and you may also have other rights which vary from state to state.

Changes in Dimensions and Specifications

All dimensions and specifications shown in Warner Electric catalogs are subject to change without notice. Weights do not include weight of boxing for shipment. Certified prints will be furnished without charge on request to Warner Electric.



www.warnerelectric.com

31 Industrial Park Road
New Hartford, CT 06057
815-389-3771
Fax: 815-389-2582

An **Altra** Industrial Motion Company

