

SF-825, SF-1000, SF-1225, SF-1525, Pin Drive Armature, Spline Drive Armature and SF-1525 Hi Torque

P-215
819-0515

Installation Instructions



Contents

Installation Instructions	
SF-825, SF-1000, SF-1225, SF-1525	
Pin Drive Armature	.3
SF-825, SF-1000, SF-1225, SF-1525 Spline	
Drive Armature and SF-1525 High Torque	
Spline Drive Armature	.6
Torque Tabs	.8
Electrical Coil Data	.9
Burnishing and Maintenance	.10
Illustration Drawings	
SF-825, SF-1000	
Bearing Mounted - Pin Drive	.12
SF-1225, SF-1525	
Bearing Mounted - Pin Drive	.16
SF-825, SF-1000	
Flange Mounted - Pin Drive	.20
SF-1225, SF-1525	
Flange Mounted - Pin Drive	.24
SF-825, SF-1000	
Bearing Mounted - Spline Drive	.30
SF-1225, SF-1525, SF-1525 Hi-Torque	
Bearing Mounted - Spline Drive	.34
SF-825, SF-1000	
Flange Mounted - Spline Drive	.40
SF-1225, SF-1525, SF-1525 Hi-Torque	
Flange Mounted - Spline Drive	.44
Bushing Part Numbers	.48
Warranty	.Back Cover

⚠ WARNING Follow the installation instructions in this manual carefully to ensure safe, reliable operation. All stated or implied manufacturer warranties are voided if this product is not installed in accordance with these instructions.

⚠ WARNING Failure to follow these instructions may result in product damage, equipment damage, and serious or fatal injury to personnel.



SF-825
Pin Drive
Bearing Mounted



SF-825
Spline Drive
Bearing Mounted

Clutch

Pin Drive Armature

SF-825 SF-1000 SF-1225 SF-1525

The illustration drawings, parts lists, and exploded views for these units can be found beginning on page 12.

A. Installing the Conduit Box

Installation instructions for the conduit box can be found with Conduit Box.

B. Mounting the Field-and-Rotor Assembly

Flange-Mounted Units

The fields and rotors are shipped separately for flange-mounted units. On some applications it will be necessary to mount the rotor first, and then bring the field into position. In other instances the field will be mounted first, and then the rotor (mounted on a shaft) will be inserted into place.

1. Mounting the Field

- a. Care must be taken in selecting the location for mounting the field assembly. Pilot diameters are machined on the field mounting flange to aid in holding the field in the proper position.
- b. An appropriate pilot diameter must be provided on the mounting surface as well. (Figure 1)

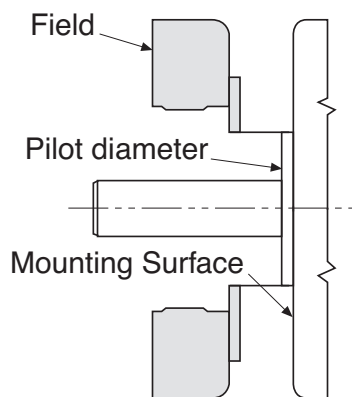

Figure 1

- c. The field assembly is then fastened in place with capscrews and lockwashers. (Figure 2)

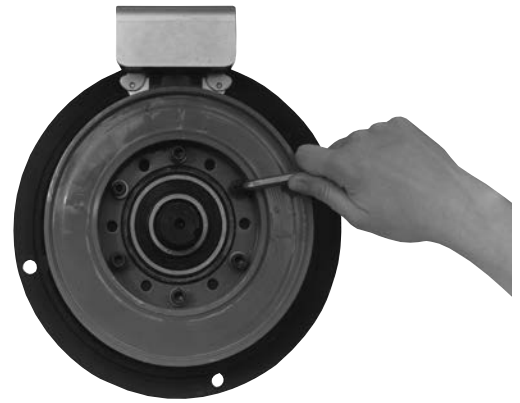

Figure 2

- d. After the unit is in place the mounting face and pilot diameter must be square and concentric with the shaft in accordance with the tolerances listed on the drawings. (Figure 3)

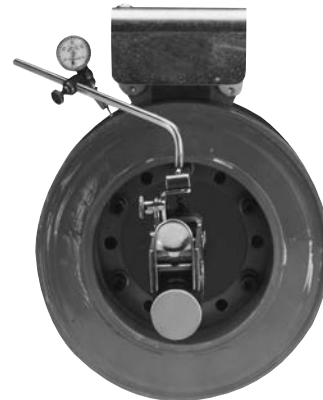

Figure 3

2. Mounting the Rotor

- a. Assemble the rotor to the rotor hub with capscrews and lockwashers. The rotor is reversible depending on the side from which the taperlock bushing must enter. A pilot diameter is machined on the rotor hub to assure a proper fit.
- b. The rotor hub is mounted on the shaft with a taperlock bushing. Be sure all parts are clean and free of dirt, chips, and burrs before assembling.
- c. Insert the bushing into the tapered bore.
- d. Loosely assemble the two locking screws between the bushing and rotor.
- e. Insert the key into the shaft keyway. Prick punch the end of the keyway to ensure that the key cannot slide out.

- f. Slide the rotor assembly over the key and onto the shaft.
- g. Place the edge of the rotor $1/16"$ - $1/8"$ before the line that is inscribed into the O.D. of the field.
- h. Lock the rotor into place by alternately tightening the two locking screws in the bushing. As the screws are tightened, the rotor normally is pulled $1/16"$ - $1/8"$ further onto the bushing (towards the field).

When the rotor is secured tightly on the bushing, the edge of the rotor must be approximately even with the line inscribed in the field. The overall axial dimension from the face of the rotor to the back of the field flange is shown on the illustration drawings. Squareness and concentricity tolerances must also be held as specified on the drawings to assure that the unit functions correctly.

Bearing-Mounted Units

In bearing-mounted units, the field and rotor are shipped as an assembly. Either this assembly or the armature and hub assembly can be mounted on the shaft first, depending on the characteristics of each application.

1. Field and rotor assemblies are mounted on the shaft with a Taperlock bushing. Insert the bushing into the tapered bore.
2. Loosely assemble the two locking screws between the Taperlock bushing and the rotor.
3. Insert the key into the shaft keyway. Prick punch the end of the keyway to ensure that the key cannot slide out.
4. Slide the rotor assembly onto the shaft over the key.
5. If the armature has been secured to the shaft first, adjust the rotor's position to allow a $1/32$ -inch gap between the two faces. (See Figure 10.)
6. Lock the assembly into place by alternately tightening the two locking screws.

7. A tab or torque arm on the field is used to prevent rotation of the field caused by normal bearing drag. Insert either a pin in the U-slot or a fork around the torque arm to prevent this rotation. Under no circumstances, however, should the field be so tightly restrained as to preload the bearing. (For more information on torque tabs, see page 8.)

C. Assembling the Armature

1. A customer may wish to use the autogap accessory to mount a clutch armature to his own pulley, hub, gear, etc. Follow the illustrated dimensions (Figures 4 & 5) to properly adapt these parts to the armature.

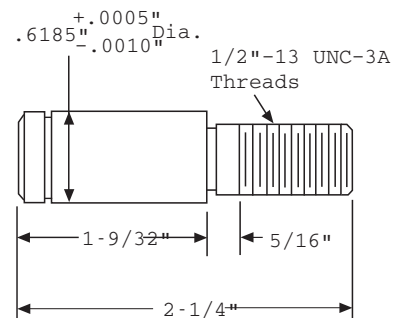
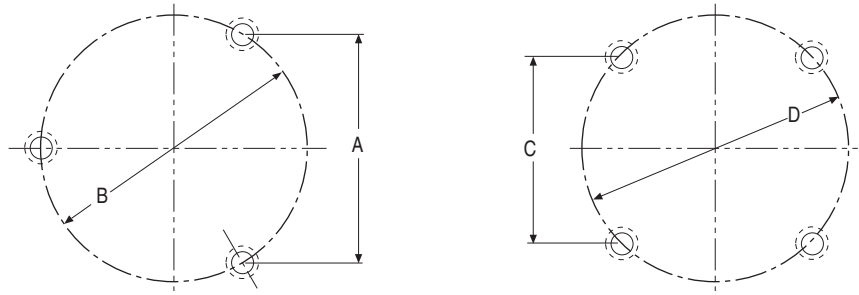

Figure 4

- a. Chordal dimensions "A" or "C" must be held for all chords between pin holes.
 - b. Drill $27/64$ -inch diameter holes to a sufficient depth, and tap for $1/2$ -13 NC-3 one-inch minimum full threads. The holes must be square with the plane of the mounting surface.
 - c. Ream $.501/.500$ to a $3/8$ -inch depth and concentric with the tapped holes.
2. Once the pulley, gear, etc., has been adapted according to the above directions, the armature may be mounted to it using the autogap accessory.
 3. The autogap assembly is a double spring device which allows for automatic armature clearance and adjustment for wear. The smaller or conical spring pushes the armature from the rotor face, leaving a gap of about $1/32$ -inch, while the straight spring automatically follows up for wear. This combination maintains maximum performance efficiency throughout the life of the unit.



Unit Size	A	B	C	D
825	3.085 ± .001	3.563 ± .001		
1000	4.548 ± .002	5.252 ± .002		
1225			4.155 ± .002	5.877 ± .002
1525			6.010 ± .002	8.500 ± .002

Figure 5

The assembly procedure for the autogap accessory is as follows:

Note: The 1225 and 1525 units are mounted with four drive pins instead of three as shown in the picture; however, the assembly procedure is the same for either case.

Step 1

Place straight (white) springs over armature bosses on back (unsegmented) side of armature. (Figure 6)



Figure 6

Step 2

Compress heavy (red) spring against retainer ring by sliding detent spring towards the head of the pin. (Figure 7)



Figure 7

Step 3

Insert assembled drive pins through armature (entering from segmented side), through straight (white) springs, and into customer-supplied part. (Figure 8)

Note: Apply Grade "AA" Loctite[®] Sealant on pin threads.

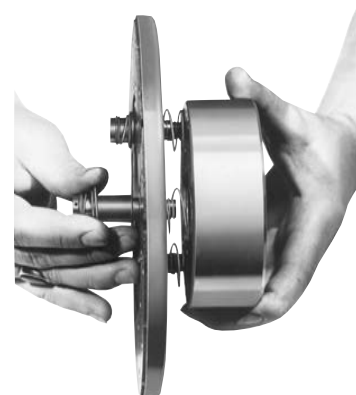

Figure 8

Step 4

Tighten pins until shoulders of pins are against face of customer-supplied part.

▲CAUTION Straight springs must not get caught under shoulders of drive pins.

Step 5

Check to see that the armature is completely compressed against the face of customer-supplied part.

Step 6

To set the autogap, slide the detent spring retainers against the armature face. (Figure 9)



Figure 9

Note: This position must not be disturbed during completion of assembly.

D. Mounting the Armature and Customer Supplied Assembly

1. Slide the armature and customer supplied assembly onto the shaft.
2. If the field-and-rotor assembly has been secured to the shaft or a machine member first, then adjust the armature's position to allow approximately 1/32-inch between the two faces. (Figure 10)

Once this 1/32-inch gap has been set, it will be automatically maintained throughout the life of the unit.

3. Secure the assembly in this position on the shaft.

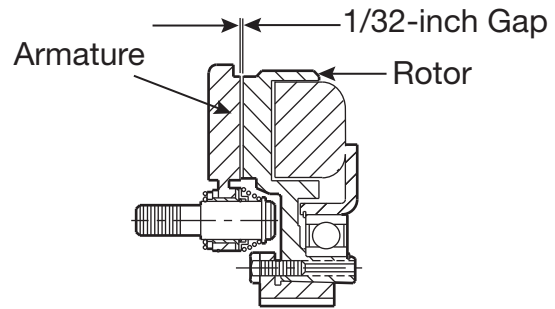

Figure 10

Clutch

Spline Drive Armature

SF-825, SF-1000, SF-1225, SF-1525

SF-1525 Hi-Torque

The illustration drawings, parts lists, and exploded views for these units can be found beginning on page 30. (SF-1525 Hi-Torque may be found on pages 28-29.)

A. Installing the Conduit Box

Install the conduit box on the field. Instructions for this procedure can be found with conduit box.

B. Mounting the Field-and-Rotor Assembly

To mount the field-and-rotor assemblies, follow the instructions provided for the SF pin drive units, page 3. Refer to either the bearing- or flange-mounted instructions, depending on the unit being installed.

C. Assembling the Armature

These units contain a spline drive armature and spline hub. The armatures are shipped with a built-in autogap spring accessory. This device automatically maintains a gap of about 1/32-inch between the armature and rotor faces for the life of the units.

1. Assemble the armature and the splined armature hub.
 - a. Place the armature assembly on a flat surface with the segmented side up.
 - b. Push the splined hub, with the retainer ring groove down, through the autogap spring and splined armature adapter. (Figure 4) (Considerable force is required to push the hub through the armature.)



Figure 4

2. A customer may assemble the clutch armature to his own free-running sheave, sprocket, or gear.
 - a. Refer to the armature view on the illustration drawings for the dimensional information needed to drill and tap holes in the customer-supplied part.
 - b. Assemble the armature to the customer-supplied part with the capscrew mounting accessory provided.

D. Mounting the Armature Assembly

1. Slide the armature-hub assembly and customer supplied part on to the shaft.
2. Position the assembly so that the face of the armature is about 1/16" from the rotor face.
3. Secure the assembly in this position by a) retainer rings, b) set collars, c) shoulder on the shaft, or d) any combination of these. The best method will depend on the characteristics of each application.
4. Set the autogap by pressing the armature into contact with the rotor face and then releasing it. The armature should spring back about 1/32". (Figure 5)

This gap will be automatically maintained for the life of the unit.

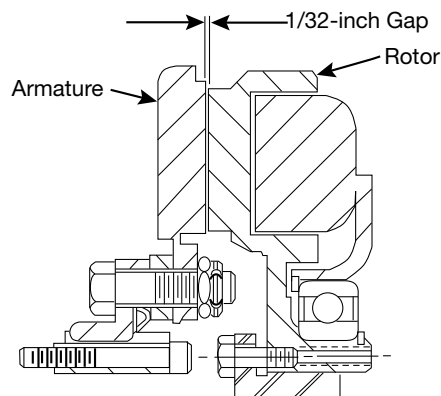

Figure 5

Torque Tabs

Clutches

Many Warner Electric clutch assemblies have a bearing mounted stationary field. By design the bearing maintains its proper position between the field and rotor making it easy for the customer to mount the field-rotor assembly. However, the bearing has a slight drag which tends to make the field rotate with the rotor if not restrained. And, since the field has lead wires attached, it must be restrained to prevent rotation and pulling of these wires. To counteract this rotational force, the field has a "torque tab" to which the customer must attach an appropriate anti-rotational restraint.

A few hints regarding proper torque tab restraints are in order. First and foremost, it is important to recognize that the force to be overcome is very small and the tab should not be restrained any manner which will preload the bearing. For example, if the clutch is mounted with the back of the field adjacent to a rigid machine member the customer should not attach a capscrew tightly between the tab and the machine member. This may pull the tab back against the rigid member as shown in Figure 1 and preload the bearing. The recommended methods are illustrated in Figure 2, 3, and 4. The method selected is primarily a matter of customer preference or convenience.

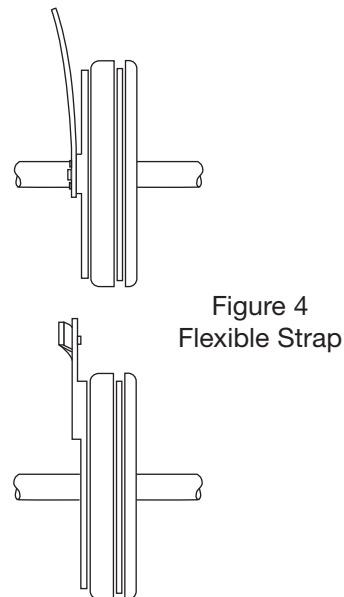
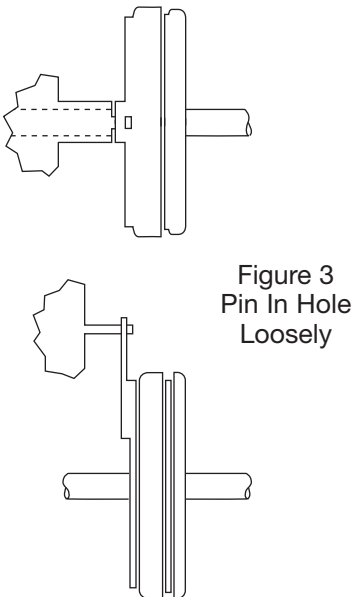
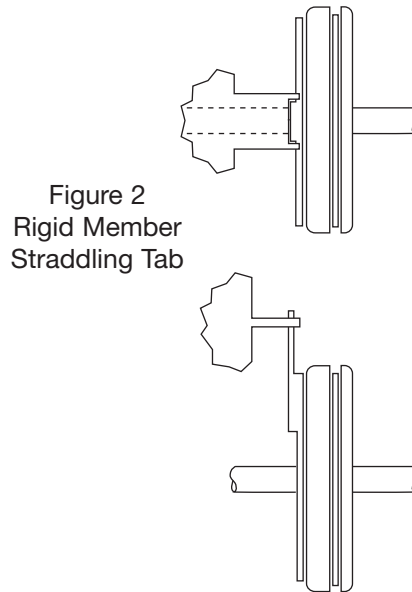
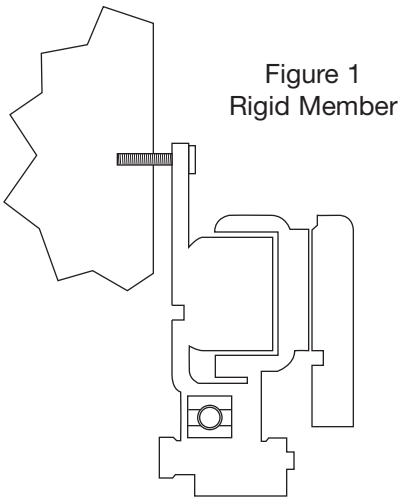

Electrical Coil Data

Unit Size	SF-825			SF-825 Brg.			SF-1000		
Voltage–DC	6	24	90	6	24	90	6	24	90
Resistance @ 20°C–Ohms	1.23	20.9	267.0	1.098	14.6	221	1.07	14.4	214.4
Current–Amperes	4.9	1.15	.34	5.464	1.65	.407	5.61	1.67	.42
Watts	29	28	30	33	40	37	34	40	38
Coil Build-Up–Milliseconds	222	200	245	180	200	225	256	275	283
Coil decay–Milliseconds	105	120	100	115	120	130	123	105	90

Unit Size	SF-1225			SF-1525			SF-1525 H.T.	
Voltage – DC	6	24	90	6	24	90	6	90
Resistance @ 20°C–Ohms	1.21	19.5	268.3	1.11	15.5	239.1	.55	113.4
Current – Amperes	4.97	1.23	.34	5.41	1.55	.38	10.83	.794
Watts	30	30	30	32	37	34	65	72
Coil Build-Up – Milliseconds	475	490	510	505	535	575	480	560
Coil decay–Milliseconds	240	230	220	230	237	215	210	160

Notes: Build-up time equals current to approx.* 90% of steady state value and flux to 90%

Decay time equals current to approx.* 10% of steady state value and flux to 10%.

*Approx. because current leads or lags flux by a small amount.

Burnishing and Maintenance

Burnishing

Intimate metal to metal contact is essential between the armature and the metal rings (poles) of the magnet or rotor. Warner Electric clutches and brakes leave the factory with the friction material slightly undercut to assure good initial contact.

Normally, the desired wearing-in process occurs naturally as the surfaces slip upon engagement. The time for wear-in, which is necessary to obtain the ultimate torque of the unit, will vary depending on speed, load, or cycle duty.

If maximum torque is required immediately after installation, the unit should be burnished by slipping the friction surfaces together at reduced voltage. It is recommended that the burnishing be done right on the application, if at all possible.

Burnishing at high speed will result in a smoother wear-in pattern and reduce the time for burnishing. The voltage should be set at approximately 30% or 40% of the rated value.

The unit should be cycled on and off to allow sufficient time between slip cycles to prevent overheating.

When a Warner Electric brake or clutch is properly assembled and installed, no further servicing, lubrication, or maintenance should be required throughout the life of the unit.

Maintenance

Wear Pattern: Wear grooves appear on the armature and rotor surfaces. This is a normal wear condition, and does not impair functioning of the unit. Normally, the rotor and armature, as a mating pair, will wear at the same rate. It is the usual recommendation that both components be replaced at the same time.

Remachining the face of a worn armature is not recommended. If a replacement armature is to be used with a used rotor, it is necessary to remachine the worn rotorface. In refacing a rotor: (1) machine only enough material to clean up the complete face of the magnet; (2) hold the face within .005" of parallel with the mounting plate; and (3) undercut the molded facing material .002"-.004" below the metal poles.

Heat: Excessive heat and high operating temperatures are causes of rapid wear. Units therefore, should be ventilated as efficiently as possible, especially if the application requires fast, repetitive cycle operation.

Foreign Materials: If units are used on machinery where fine, abrasive dust, chips or grit are dispelled into the atmosphere, shielding of the brake or clutch may be necessary if maximum life is to be obtained.

Where units are used near gear boxes or transmissions requiring frequent lubrication, means should be provided to protect the friction surfaces from oil and grease to prevent serious loss of torque.

Oil and grease accidentally reaching the friction surfaces may be removed by wiping with a rag dampened with a suitable cleaner, which leaves no residue. In performing this operation, do not drench the friction material.

If the friction materials have been saturated with oil or grease, no amount of cleaning will be completely effective. Once such a unit has been placed back in service, heat will cause the oil to boil to the surface, resulting in further torque loss.

Torque Loss: If a brake or clutch slips or loses torque completely, the initial check should be the input voltage to the field as follows:

90-Volt Series: Connect a DC voltmeter with a range of 0-100 or more directly across the field terminals. With the power on and the potentiometer turned up, a normal reading is 90 volts, although 85 to 95 is satisfactory. The reading should drop as the potentiometer control is adjusted counterclockwise.

24-Volt Series: Use a DC voltmeter with a range of 0-30 volts or more. A normal reading is approximately 22-26 volts.

6-Volt Series: Use a DC voltmeter of approximately 0-15 volt range. A normal reading is from 5.5 to 6.5 volts.

The above checks normally are sufficient. Further checks may be made as follows: a low range ammeter, when connected in series with one field lead, will normally indicate approximately .40 amperes for the 90 volt units, 1.0 ampere for the 24 volt, and 3.5 amperes for the 6 volt series. These readings are with the power on and the potentiometer control in the maximum position.

Ohmmeter checks should be made with the power off and the circuit open (to be certain, disconnect one lead to the field). Average resistance for the 90 volt series is 220 ohms; for the 24 volt, 20 ohms; and for the 6 volt series, 1.5 ohms. A very high or infinite resistance reading would indicate an open coil.

If the above checks indicate that the proper voltage and current is being supplied to the magnet, mechanical parts should be checked to assure that they are in good operating condition and properly installed.

SF-825 Clutch Bearing Mounted–Normal Duty

Drawing I-25575

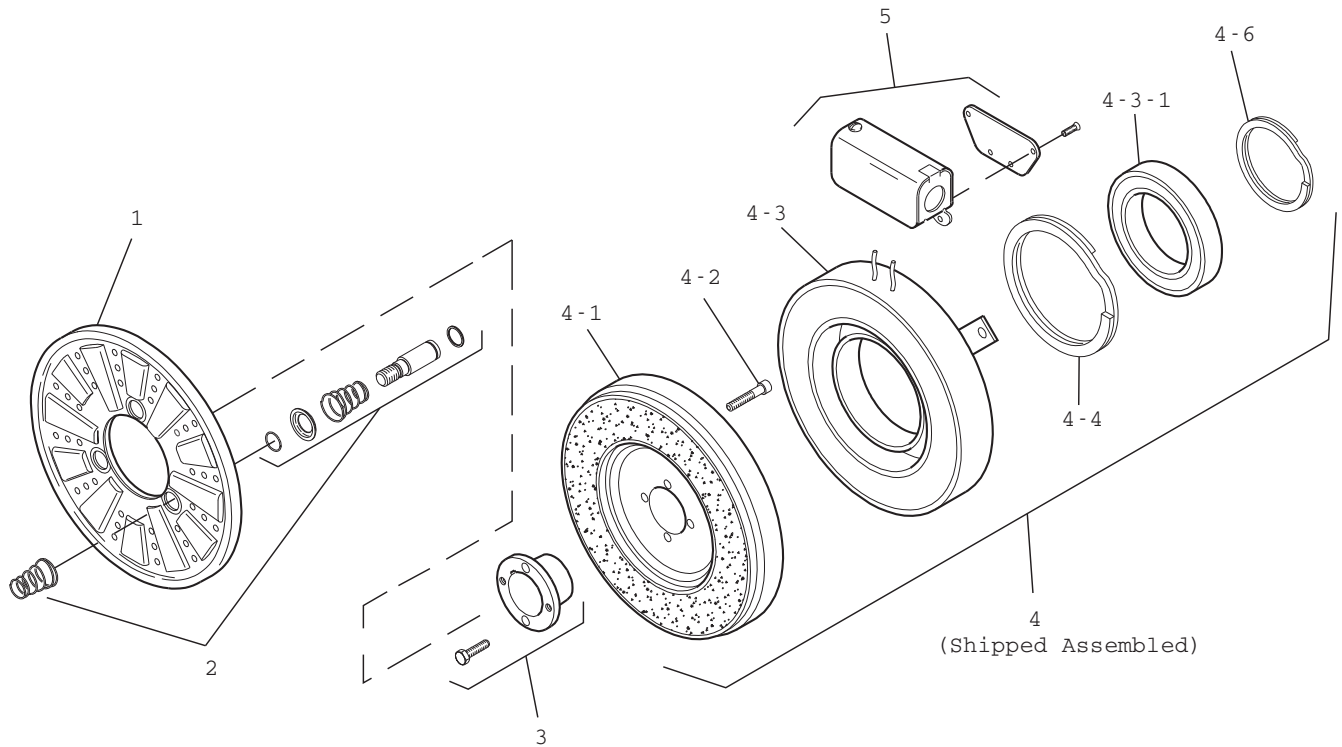

Item	Description	SF-825, B.M. Part Number	Qty.
1	Armature	5301-111-018	1
2	Autogap Accessory	5201-101-008	3
3	Bushing	1/2" to 1-1/2" Bore 180-0002 to 180-0018*	1
4	Field & Rotor Assembly		1
	6 Volt	5201-452-002	
	24 Volt	5201-452-004	
	90 Volt	5201-452-006	
4-1	Rotor		1
	Standard Friction Material	5201-751-008	
4-2	Mounting Accessory	5201-101-005	1
4-3	Field & Bearing Assembly		1
	6 Volt	5201-451-054	
	24 Volt	5201-451-056	
	90 Volt	5201-451-057	
4-3-1	Ball Bearing	166-0142	1
4-4	Retainer Ring	748-0111	1
4-6	Retainer Ring	748-0016	1
5	Conduit Box	5200-101-012	1

*See page 48 for specific part numbers.

How to Order:

1. Specify Bore Size for Item 3.
2. Specify Voltage for Item 4.

Example:

SF-825 Clutch per I-25575 - 90 Volt, 1" Bore

These units, when used in conjunction with the correct Warner Electric conduit box, meet the standards of UL508 and are listed under guide card #NMTR, file #59164. These units are CSA certified under file #LR11543.

SF-1000 Clutch Bearing Mounted-Normal Duty

See page 5 for details on drive pin mountings.

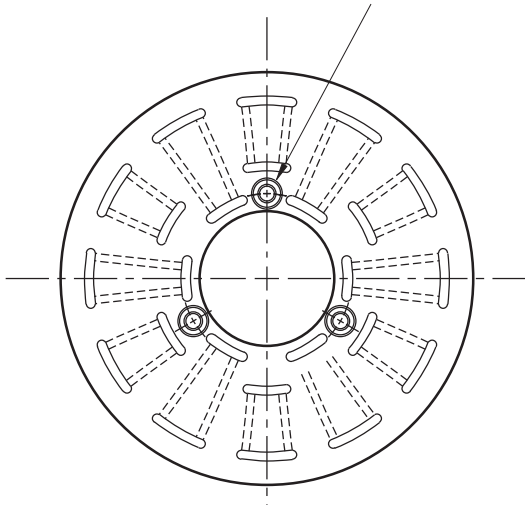

Armature View

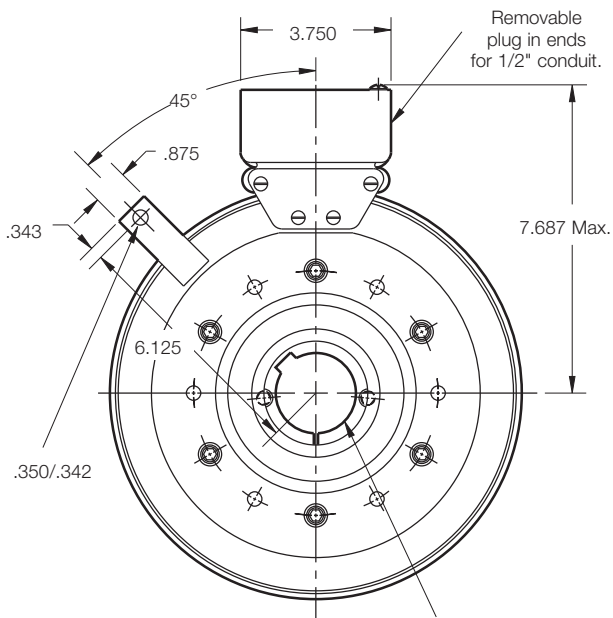
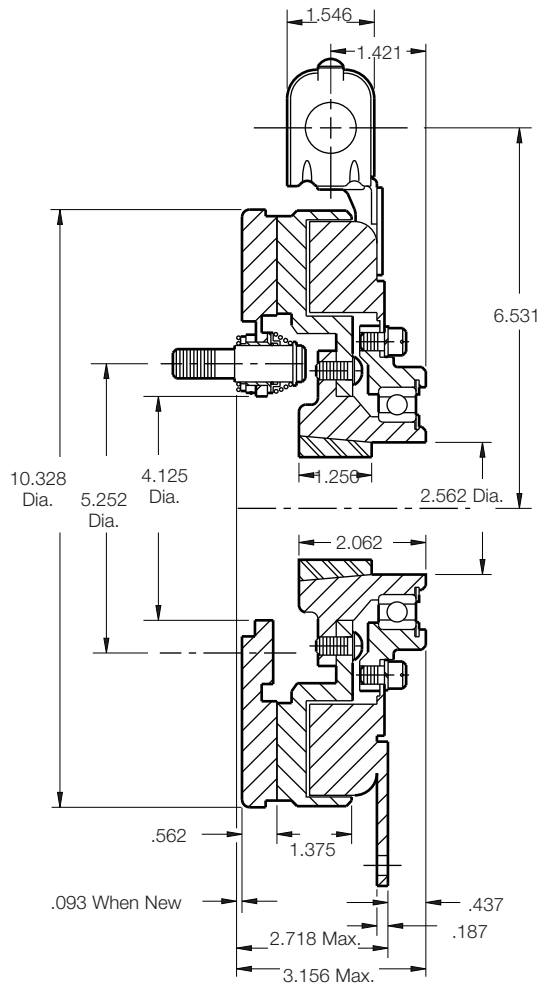

Field View

Shaft Size	.500 – 2.000
Static Torque	240 lb. ft.
Maximum Speed	2,500 rpm
Standard Voltage	D.C. 6, 24, 90

All dimensions are nominal unless otherwise noted.

SF-1000 Clutch Bearing Mounted–Normal Duty

Drawing I-25596

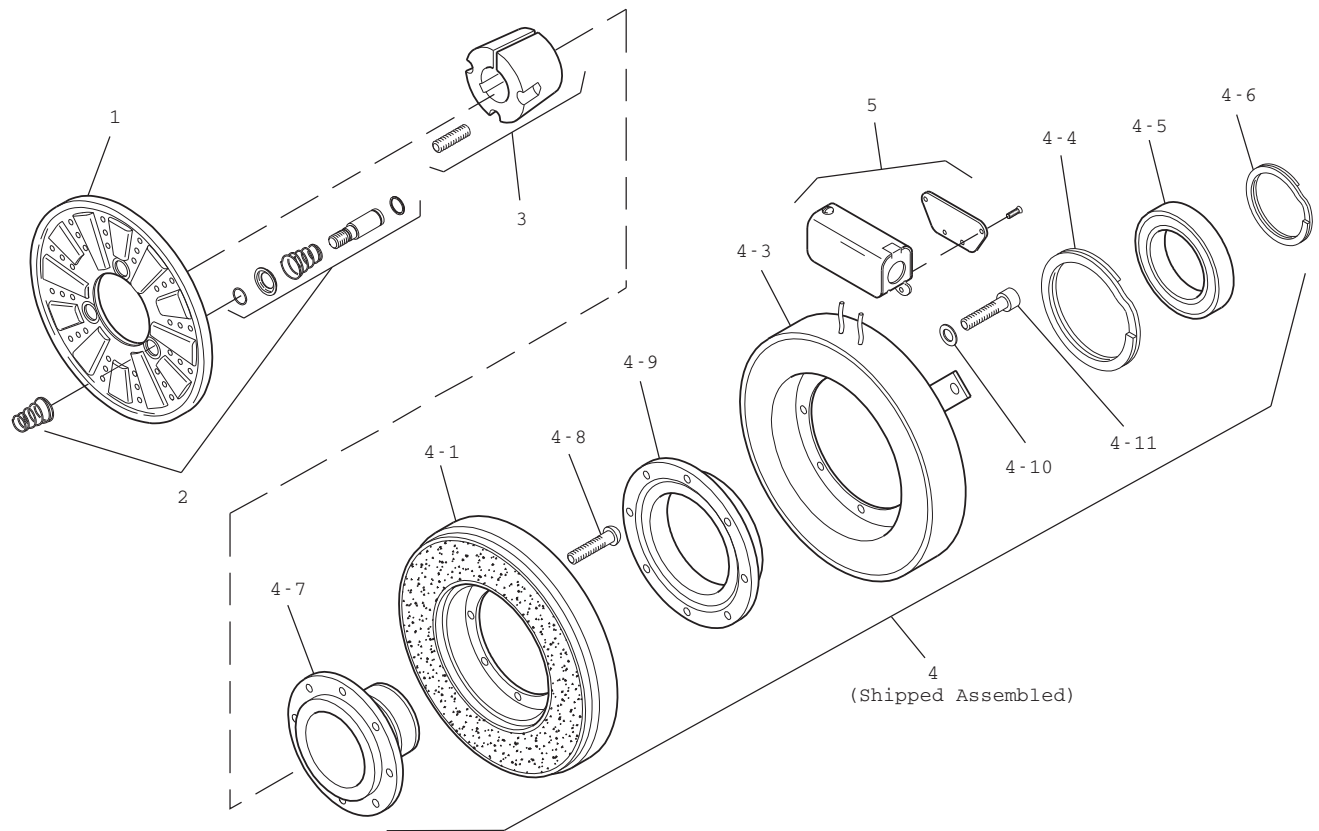

Item	Description	SF-1000, B.M. Part Number	Qty.
1	Armature	5302-111-013	1
2	Autogap Accessory	5201-101-008	3
3	Bushing		
	1/2" to 2" Bore	180-0155 to 180-0179*	1
4	Field & Rotor Assembly		1
	6 Volt	5202-452-012	
	24 Volt	5202-452-014	
	90 Volt	5202-452-015	
4-1	Rotor		1
	Standard Friction Material	5202-751-003	
	†Optional LK Facing	5202-751-007	
4-3	Field		1
	6 Volt	5202-451-040	
	24 Volt	5202-451-042	
	90 Volt	5202-451-043	
4-4	Retainer Ring	748-0116	1
4-5	Ball Bearing	166-1046	1
4-6	Retainer Ring	748-0582	1
4-7	Rotor Hub	540-1300	1
4-8	Buttonhead Capscrew	797-1261	6
4-9	Ring Adapter	748-1047	1
4-10	Lockwasher	950-0359	6
4-11	Socket Head Capscrew	797-0424	6
5	Conduit Box	5200-101-012	1

*See page 48 for specific part numbers. †Optional LK facing available.

How to Order:

1. Specify Bore Size for Item 3.
2. Specify Voltage for Item 4.

Example:

SF-1000 Clutch per I-25596 - 90 Volt, 1" Bore

These units, when used in conjunction with the correct Warner Electric conduit box, meet the standards of UL508 and are listed under guide card #NMTR, file #59164. These units are CSA certified under file #LR11543.

SF-1225 Clutch Bearing Mounted-Normal Duty

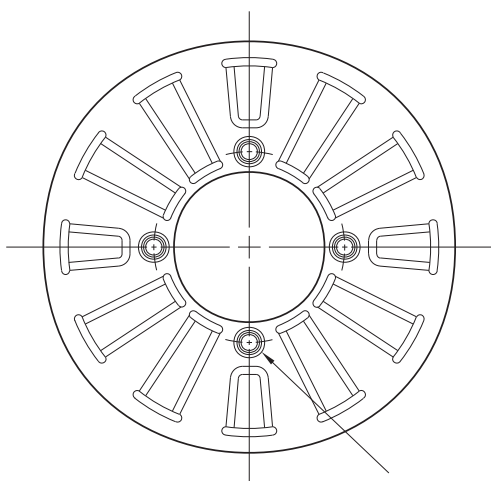

See page 5 for details on Drive Pin mountings.

Armature View

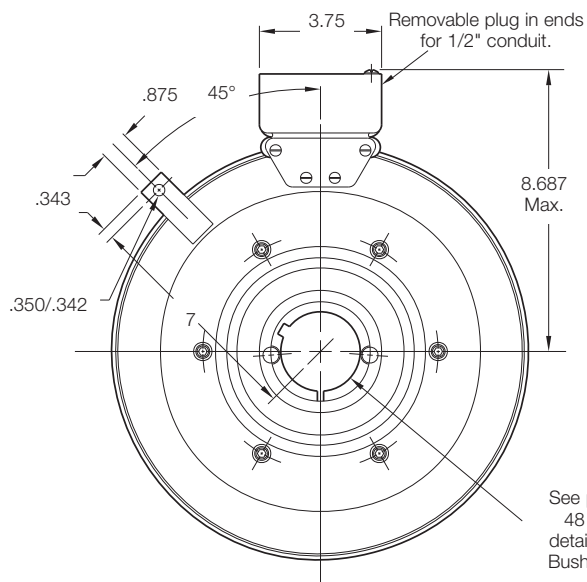

See page 48 for details on Bushings.

Field View

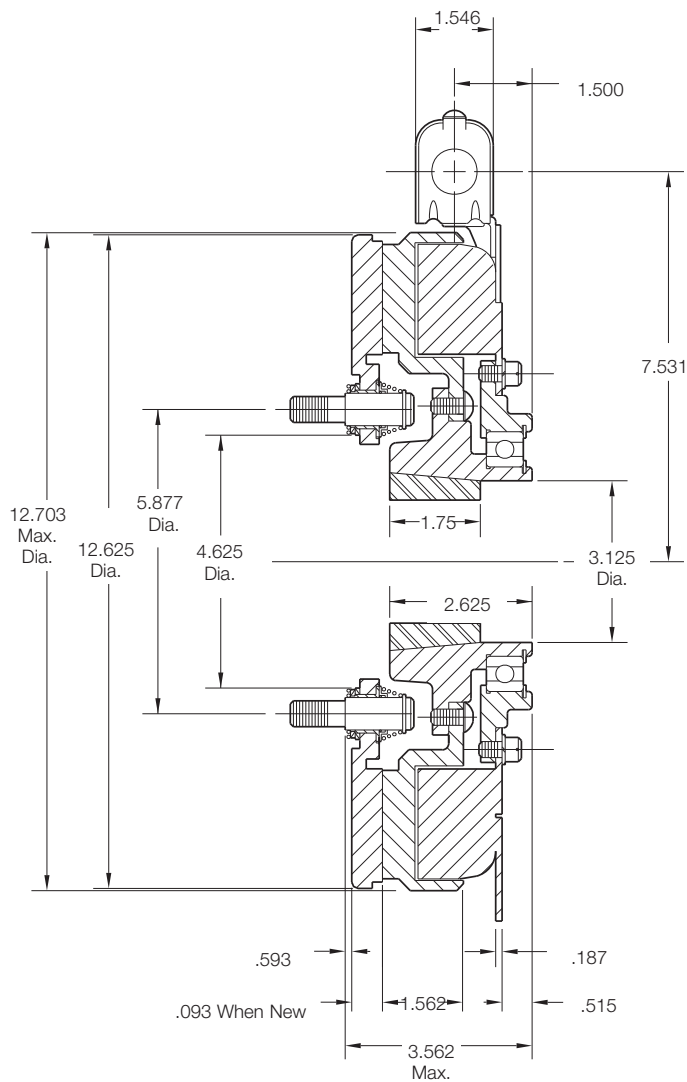

Shaft Size	.500 – 2.500
Static Torque	465 lb. ft.
Maximum Speed	2,200 rpm
Standard Voltage	D.C. 6, 24, 90

All dimensions are nominal unless otherwise noted.

SF-1225 Clutch Bearing Mounted–Normal Duty

Drawing I-25621

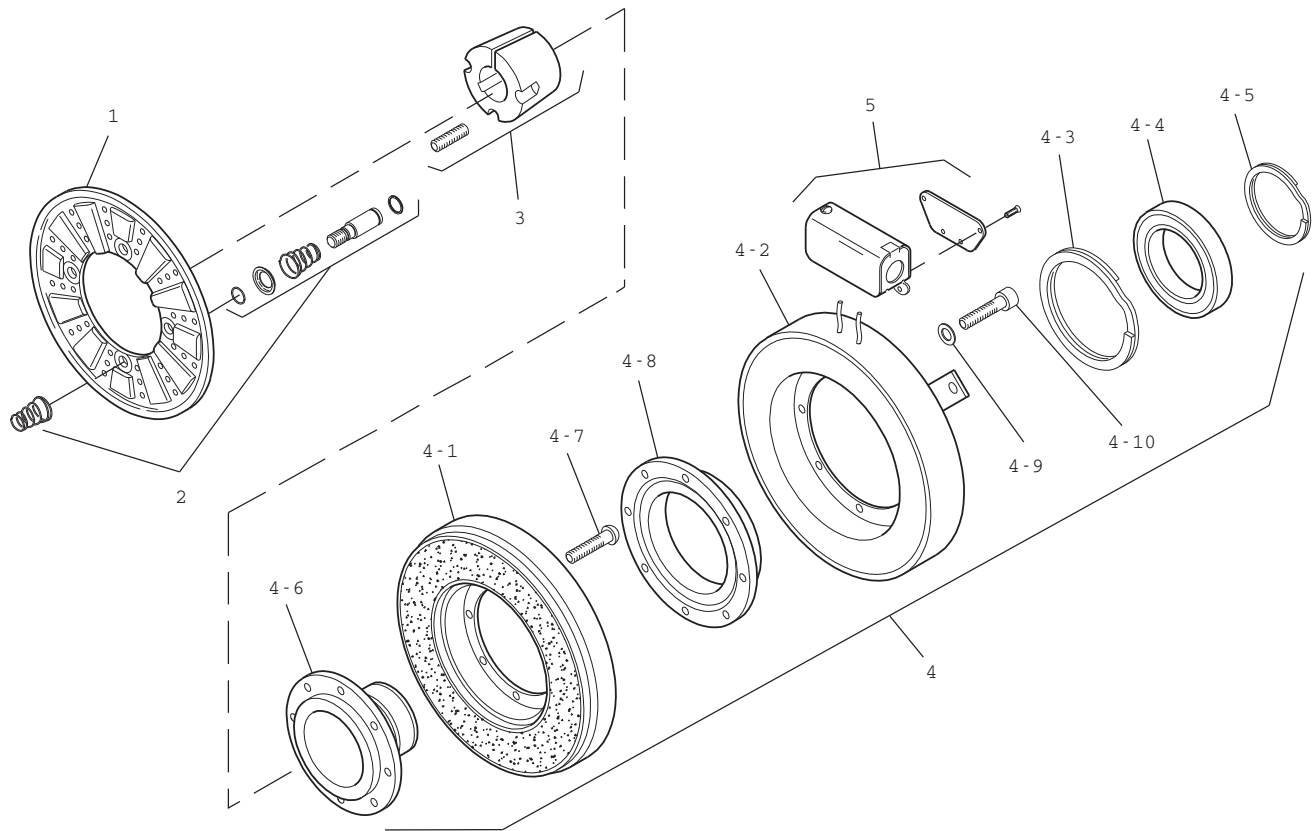

Item	Description	SF-1225, B.M. Part Number	Qty.
1	Armature	5303-111-009	1
2	Autogap Accessory	5201-101-008	4
3	Bushing		
	1/2" to 2-1/2" Bore	180-0185 to 180-0217*	1
4	Field & Rotor Assembly		1
	6 Volt	5203-452-009	
	24 Volt	5203-452-011	
	90 Volt	5203-425-012	
4-1	Rotor		1
	Standard Friction Material	5203-751-001	
	†Optional LK Facing	5203-751-004	
4-2	Field		1
	6 Volt	5203-451-034	
	24 Volt	5203-451-036	
	90 Volt	5203-451-037	
4-3	Retainer Ring	748-0119	1
4-4	Ball Bearing	166-1047	1
4-5	Retainer Ring	748-0011	1
4-6	Rotor Hub	540-1304	1
4-7	Buttonhead Capscrew	797-1261	8
4-8	Ring Adapter	748-0591	1
4-9	Lockwasher	950-0359	6
4-10	Socket Head Capscrew	797-0424	6
5	Conduit Box	5200-101-012	1

*See page 48 for specific part numbers. †Optional LK facing available.

How to Order:

1. Specify Bore Size for Item 3.
2. Specify Voltage for Item 4.

Example:

SF-1225 Clutch per I-25621 - 90 Volt, 1" Bore

These units, when used in conjunction with the correct Warner Electric conduit box, meet the standards of UL508 and are listed under guide card #NMTR, file #59164. These units are CSA certified under file #LR11543.

SF-1525 Clutch Bearing Mounted-Normal Duty

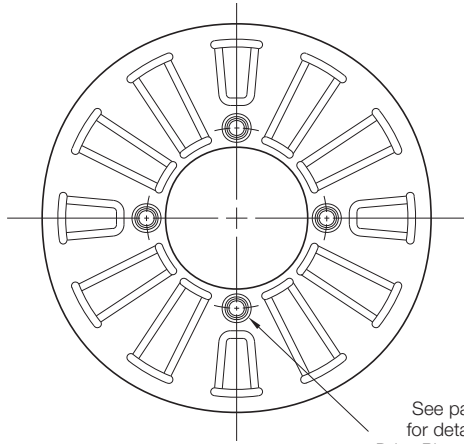

Armature View

See page 5 for details on Drive Pin mountings.

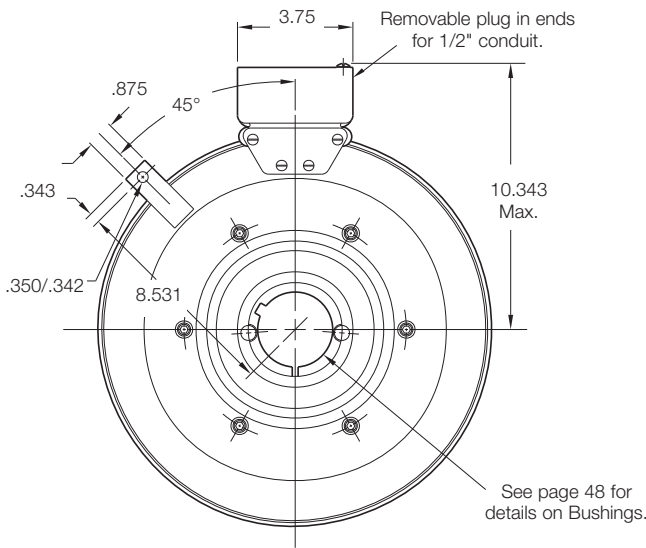

Field View

See page 48 for details on Bushings.

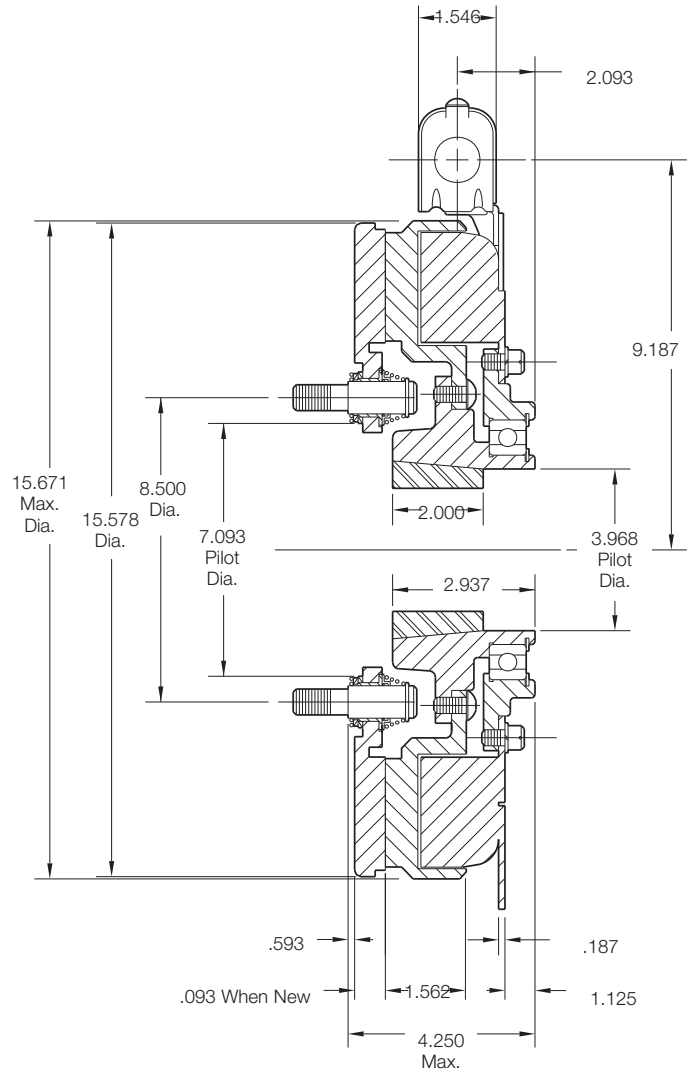

Shaft Size	.9375 – 3.00
Static Torque	700 lb. ft.
Maximum Speed	1,800 rpm
Standard Voltage	D.C. 6, 24, 90

All dimensions are nominal unless otherwise noted.

SF-1525 Clutch Bearing Mounted–Normal Duty

Drawing I-25639

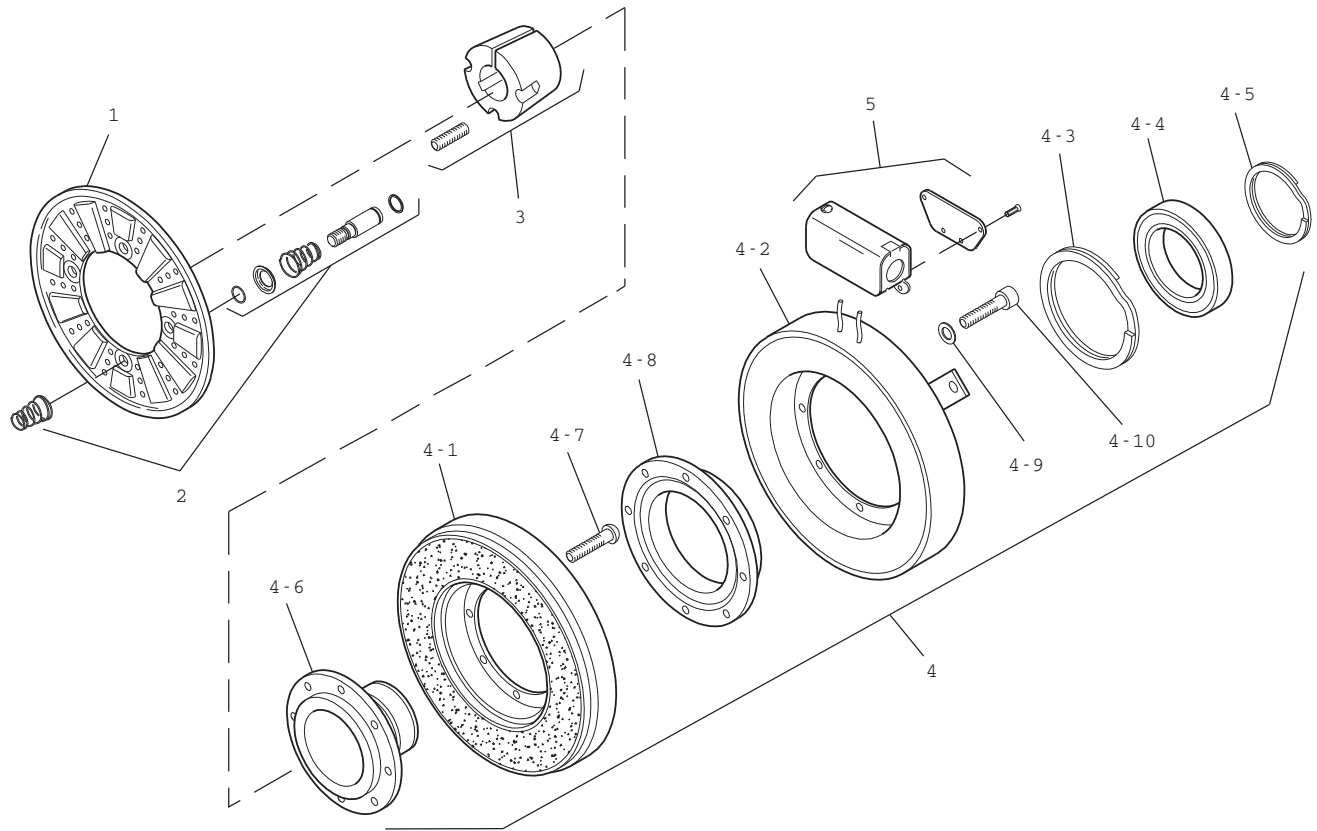

Item	Description	SF-1525, B.M. Part Number	Qty.
1	Armature	5304-111-004	1
2	Autogap Accessory	5201-101-008	4
3	Bushing		
	15/16" to 3" Bore	180-0223 to 180-0256*	1
4	Field & Rotor Assembly		1
	6 Volt	5204-452-009	
	24 Volt	5204-452-011	
	90 Volt	5204-425-012	
4-1	Rotor		1
	Standard Friction Material	5204-751-002	
	†Optional LK Facing	5204-751-004	
4-2	Field		1
	6 Volt	5204-451-084	
	24 Volt	5204-451-086	
	90 Volt	5204-451-087	
4-3	Retainer Ring	748-0114	1
4-4	Ball Bearing	166-0163	1
4-5	Retainer Ring	748-0583	1
4-6	Rotor Hub	540-1306	1
4-7	Buttonhead Capscrew	797-1261	8
4-8	Ring Adapter	748-1048	1
4-9	Lockwasher	950-0359	6
4-10	Socket Head Capscrew	797-0424	6
5	Conduit Box	5200-101-012	1

*See page 48 for specific part numbers. †Optional LK facing available.

How to Order:

1. Specify Bore Size for Item 3.
2. Specify Voltage for Item 4.

Example:

SF-1525 Clutch per I-25639 - 90 Volt, 1" Bore

These units, when used in conjunction with the correct Warner Electric conduit box, meet the standards of UL508 and are listed under guide card #NMTR, file #59164. These units are CSA certified under file #LR11543.

SF-825 Clutch Flange Mounted-Normal Duty

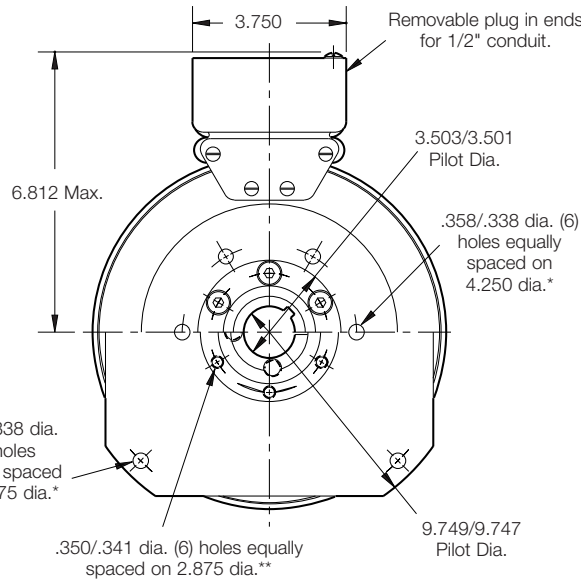
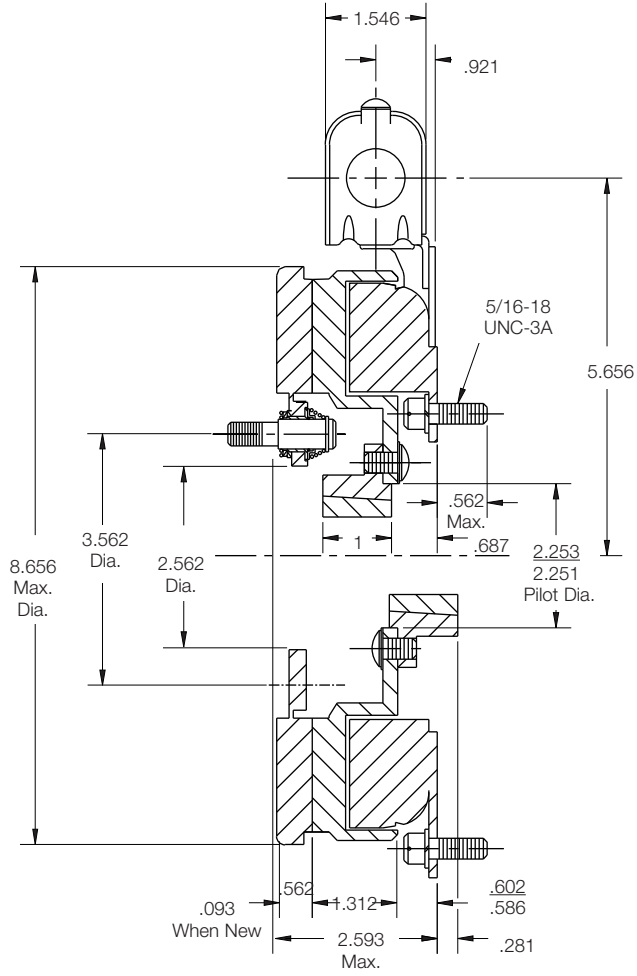
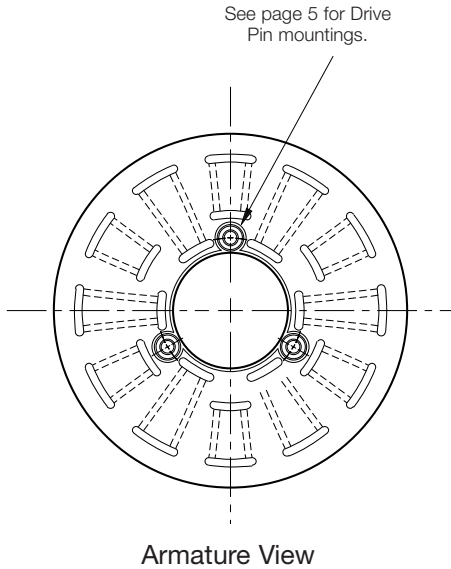

* Mounting holes are within .010 of true position relative to pilot diameter.
 ** Mounting holes are within .008 of true position relative to pilot diameter.

Customer Shall Maintain:

1. Concentricity of field mounting pilot diameter with rotor mounting shaft within .006 T.I.R.
2. Squareness of field mounting face with shaft within .006 T.I.R. measured at field mounting bolt circle.
3. Rotor mounting pilot diameter must be concentric with shaft within .006 T.I.R.

Shaft Size	.500 – 1.250
Static Torque	125 lb. ft.
Maximum Speed	4,000 rpm
Standard Voltage	D.C. 6, 24, 90

All dimensions are nominal unless otherwise noted.

SF-825 Clutch Flange Mounted–Normal Duty

Drawing I-25560

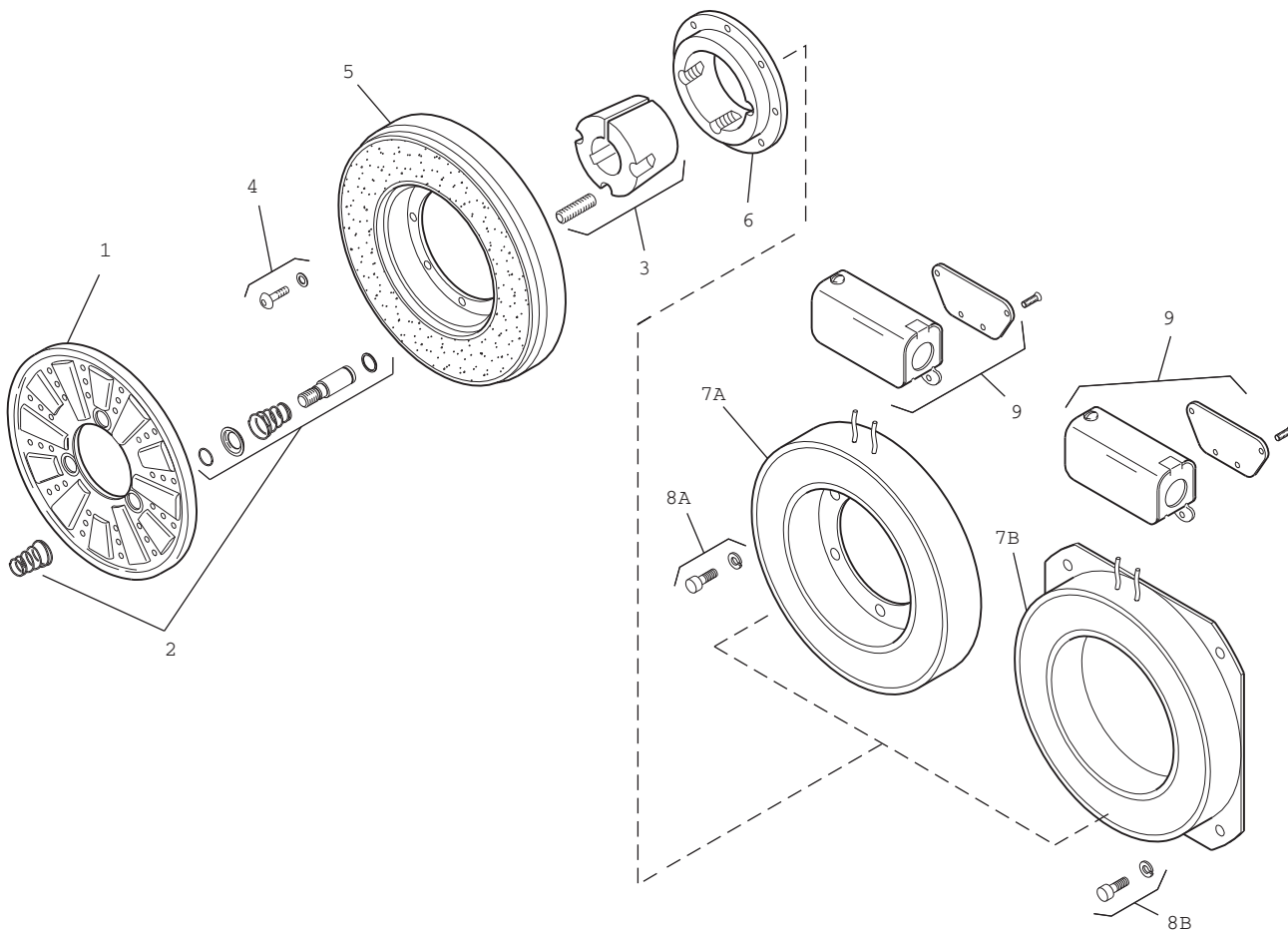

SF-825, F.M.			
Item	Description	Part Number	Qty.
1	Armature	5301-111-018	1
2	Autogap Accessory	5201-101-008	3
3	Bushing		
	1/2" to 1-1/4" Bore	180-0101 to 180-0113*	1
4	Mounting Accessory	5201-101-007	1
5	Rotor		
	Standard Friction Material	5201-751-003	
	†Optional LK Facing	5201-751-007	
6	Rotor Hub	540-0013	1
7A	Field - Inside Mounted		
	6 Volt	5201-451-006	
	24 Volt	5201-451-008	
	90 Volt	5201-451-010	
7B	Field - Outside Mounted		
	6 Volt	5201-451-014	1
	24 Volt	5201-451-016	
	90 Volt	5201-451-018	
8A	Mounting Accessory - I.M.	5321-101-001	1
8B	Mounting Accessory - O.M.	5321-101-002	1
9	Conduit Box	5200-101-012	1

*See page 48 for specific part numbers. †Optional LK facing available.

How to Order:

1. Specify Bore Size for Item 3.
2. Specify Voltage for Items 8A or 8B.
3. Specify Inside Mounted for Items 8A and 9A or Outside Mounted for Items 8B and 9B.

Example:

SF-825 Clutch per I-25560–90 Volt, 1" Bore, Inside Mounted.

Note: The two mating shafts on which the clutch is mounted must be mounted rigidly to prevent flexing during engagement. Any flexing will cause vibration and rapid clutchwear. The drive motor should not be mounted on the reducer "scoop" mount or other flexible mounts.

These units, when used in conjunction with the correct Warner Electric conduit box, meet the standards of UL508 and are listed under guide card #NMTR, file #59164.

These units are CSA certified under file #LR11543.

SF-1000 Clutch Flange Mounted—Normal Duty

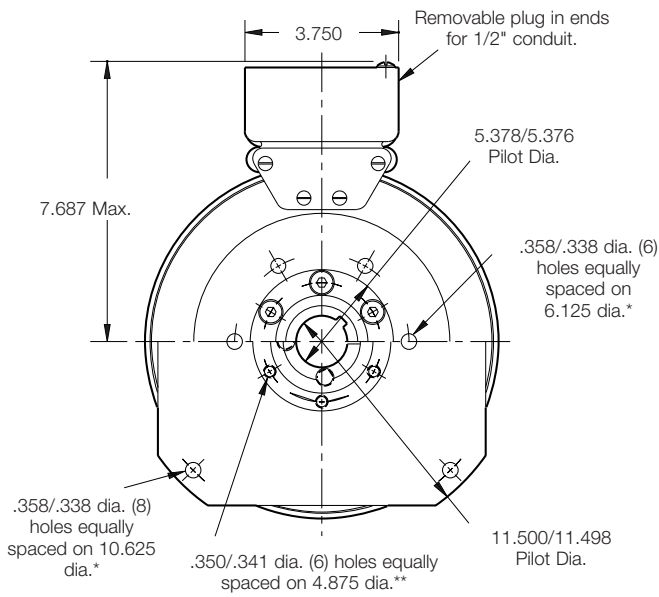
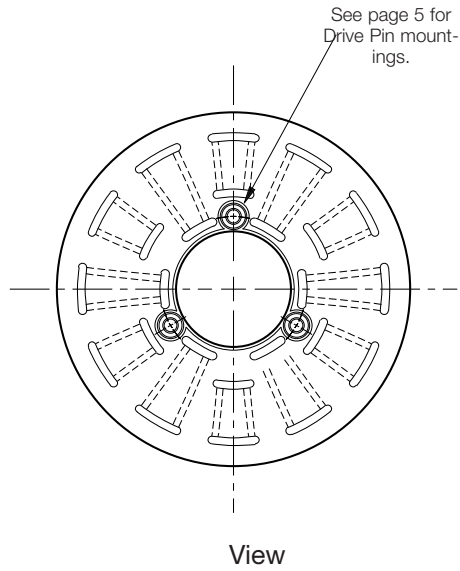

Field View
(Inside & Outside Mounted)

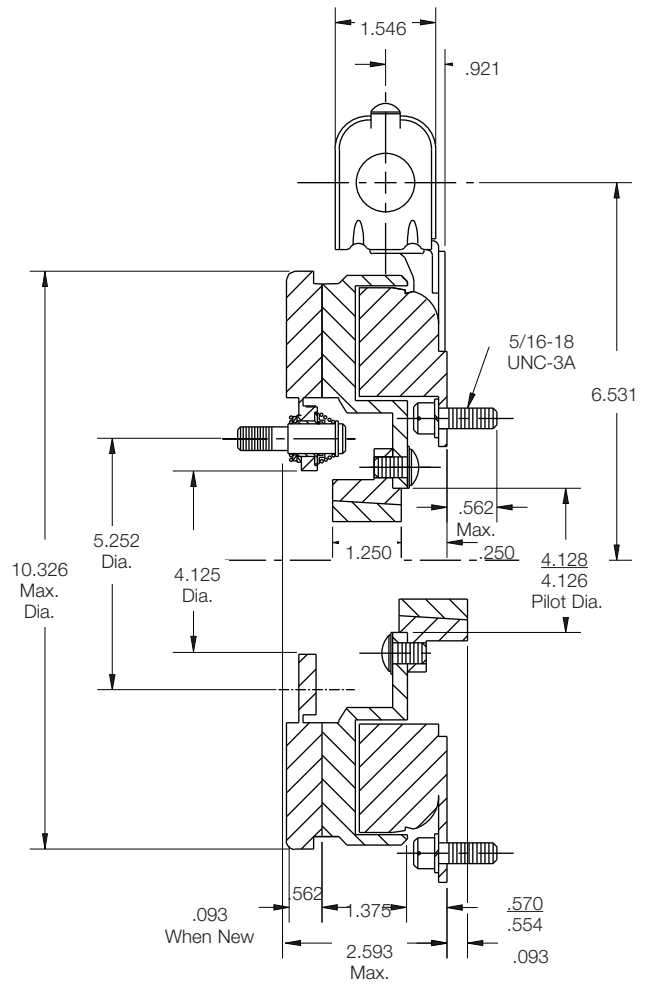

* Mounting holes are within .010 of true position relative to pilot diameter.

** Mounting holes are within .008 of true position relative to pilot diameter.

Customer Shall Maintain:

1. Concentricity of field mounting pilot diameter with rotor mounting shaft within .006 T.I.R.
2. Squareness of field mounting face with shaft within .006 T.I.R. measured at field mounting bolt circle.
3. Rotor mounting pilot diameter must be concentric with shaft within .006 T.I.R.

Shaft Size	.500 – 2.000
Static Torque	240 lb. ft.
Maximum Speed	3,600 rpm
Standard Voltage	D.C. 6, 24, 90

All dimensions are nominal unless otherwise noted.

SF-1000 Clutch Flange Mounted-Normal Duty

Drawing I-25580

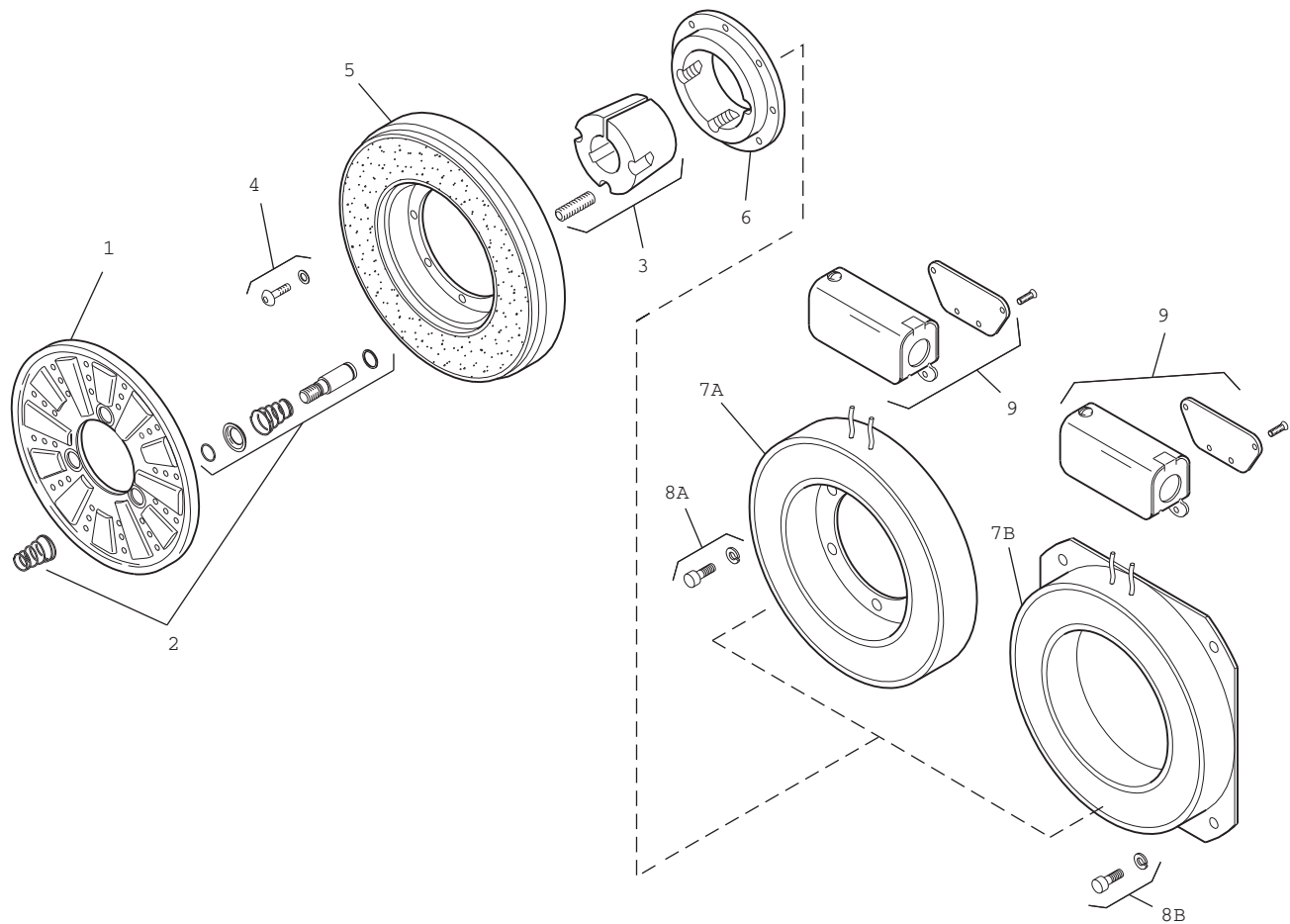

SF-1000, F.M.			
Item	Description	Part Number	Qty.
1	Armature	5302-111-013	1
2	Autogap Accessory	5201-101-008	3
3	Bushing		
	1/2" to 2" Bore	180-0155 to 180-0179*	
4	Mounting Accessory	5201-101-007	1
5	Rotor		1
	Standard Friction Material	5202-751-003	
	†Optional LK Facing	5202-751-007	
6	Rotor Hub	540-0315	1
7A	Field - Inside Mounted		1
	6 Volt	5202-451-004	
	24 Volt	5202-451-006	
	90 Volt	5202-451-007	
7B	Field - Outside Mounted		1
	6 Volt	5202-451-011	
	24 Volt	5202-451-013	
	90 Volt	5202-451-014	
8A	Mounting Accessory - I.M.	5321-101-001	1
8B	Mounting Accessory - O.M.	5321-101-002	2
9	Conduit Box	5200-101-012	1

*See page 48 for specific part numbers. †Optional LK facing available.

How to Order:

1. Specify Bore Size for Item 3.
2. Specify Voltage for Items 8A or 8B.
3. Specify Inside Mounted for Items 8A and 9A or Outside Mounted for Items 8B and 9B.

Example:

SF-1000 Clutch per I-25580 -90 Volt, 1" Bore, Inside Mounted

Note: The two mating shafts on which the clutch is mounted must be mounted rigidly to prevent flexing during engagement. Any flexing will cause vibration and rapid clutchwear. The drive motor should not be mounted on the reducer "scoop" mount or other flexible mounts.

These units, when used in conjunction with the correct Warner Electric conduit box, meet the standards of UL508 and are listed under guide card #NMTR, file #59164.

These units are CSA certified under file #LR11543.

SF-1225 Clutch Flange Mounted–Normal Duty

See page 5 for details on Drive Pin mountings.

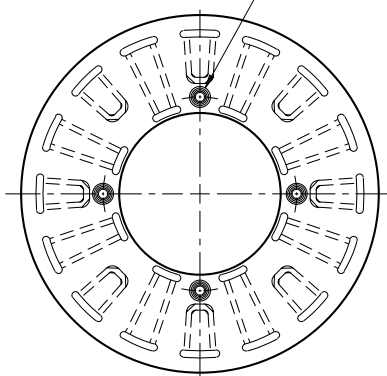

Armature View

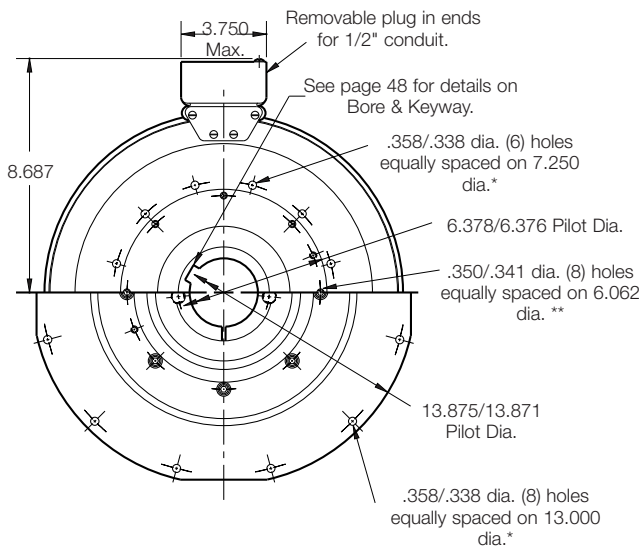

Field View
(Inside & Outside Mounted)

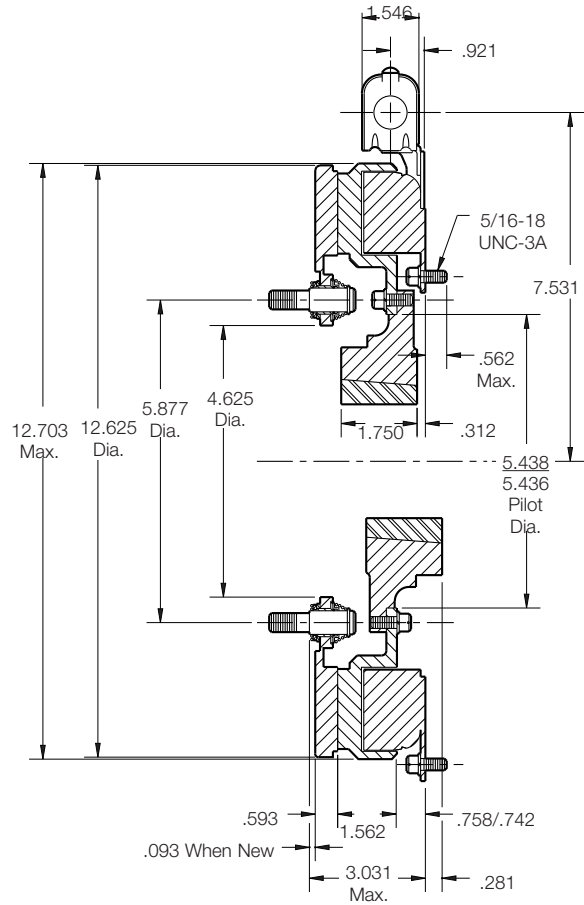

* Mounting holes are within .010 of true position relative to pilot diameter.

** Mounting holes are within .008 of true position relative to pilot diameter.

Customer Shall Maintain:

1. Concentricity of field mtg. pilot dia. with rotor mtg. shaft within .006 T.I.R.
2. Squareness of field mtg. face with rotor mtg. shaft within .006 T.I.R. measured at field mtg. bolt circle.
3. Rotor mtg. shaft concentric with armature center of rotation within .006 T.I.R.
4. Armature hub pilot dia. to be concentric with armature center of rotation within .010 T.I.R.

Shaft Size	.500 – 2.500
Static Torque	465 lb. ft.
Maximum Speed	3,000 rpm
Standard Voltage	D.C. 6, 24, 90

All dimensions are nominal unless otherwise noted.

SF-1225 Clutch Flange Mounted–Normal Duty

Drawing I-25600

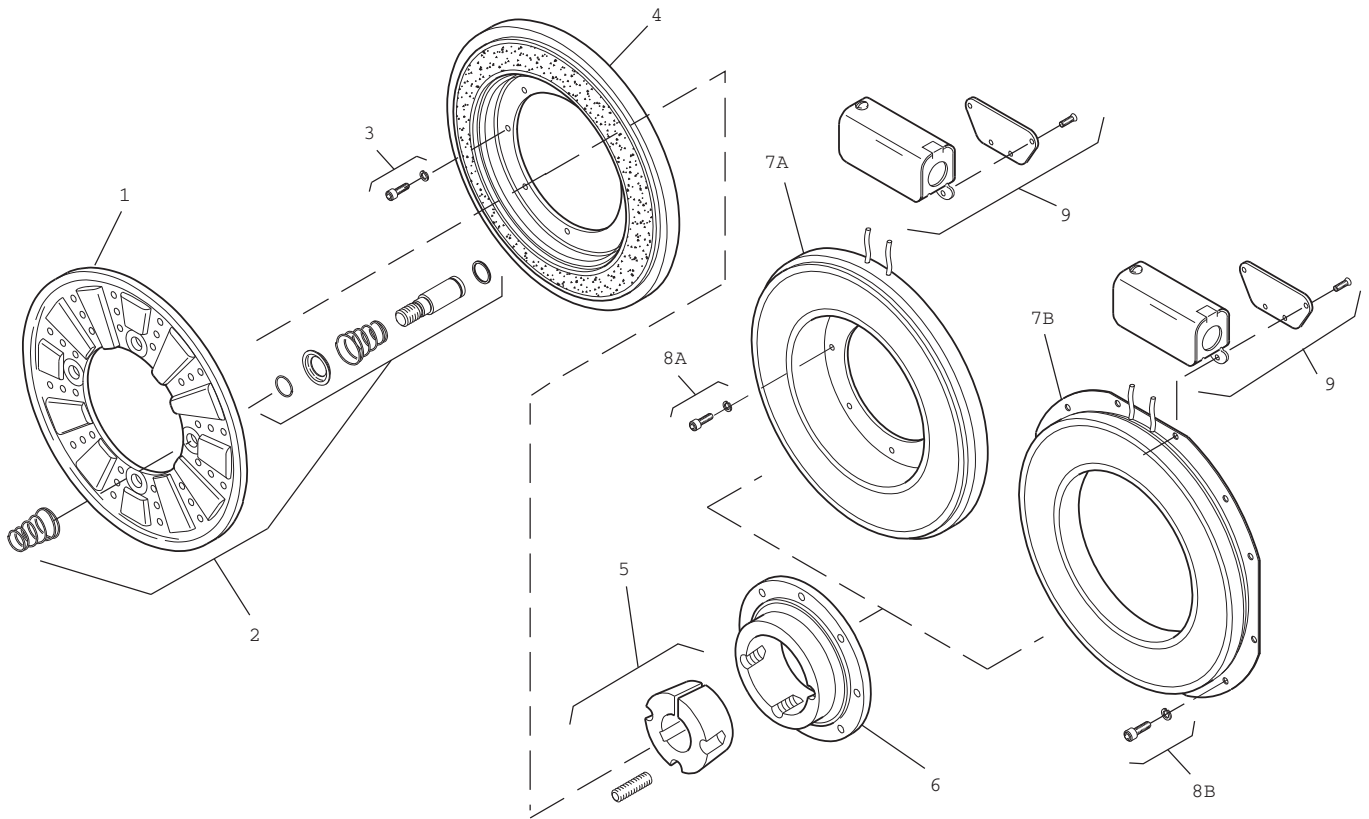

SF-1225			
Item	Description	Part Number	Qty.
1	Armature	5303-111-009	1
2	Autgap Accessory	5201-101-008	4
3	Mounting Accessory	5321-101-002	2
4	Rotor		1
	Standard Friction Material	5201-751-001	
	†Optional LK Facing	5203-751-004	
5	Bushing		
	1/2" to 2-1/2" Bore	180-0185 to 180-0217	1
6	Rotor Hub	540-0318	1
7A	Field - Inside Mounted		1
	6 Volt	5203-451-002	
	24 Volt	5203-451-006	
	90 Volt	5203-451-005	
7B	Field - Outside Mounted		1
	6 Volt	5203-451-010	
	24 Volt	5203-451-013	
	90 Volt	5203-451-011	
8A	Mounting Accessory - I.M.	5321-101-001	1
8B	Mounting Accessory - O.M.	5321-101-002	2
9	Conduit Box	5200-101-012	1

*See page 48 for specific part numbers. Optional LK facing available.

How to Order:

1. Specify Bore Size for Item 5.
2. Specify Voltage for Item 7A or 7B.
3. Specify Inside Mounted for Items 7A and 8A or Outside Mounted for Items 7B and 8B.

Example:

SF-1225 Clutch per I-25600 - 90 Volt, 1-1/2" Bore, Inside Mounted.

These units, when used in conjunction with the correct Warner Electric conduit box, meet the standards of UL508 and are listed under guide card #NMTR, file #59164. These units are CSA certified under file #LR11543.

SF-1525 Clutch Flange Mounted–Normal Duty

See page 5 for details on Drive Pin mountings.

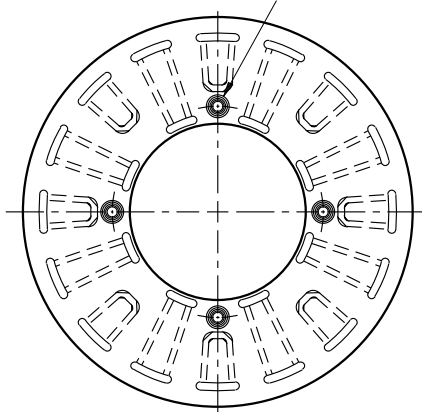

Armature View

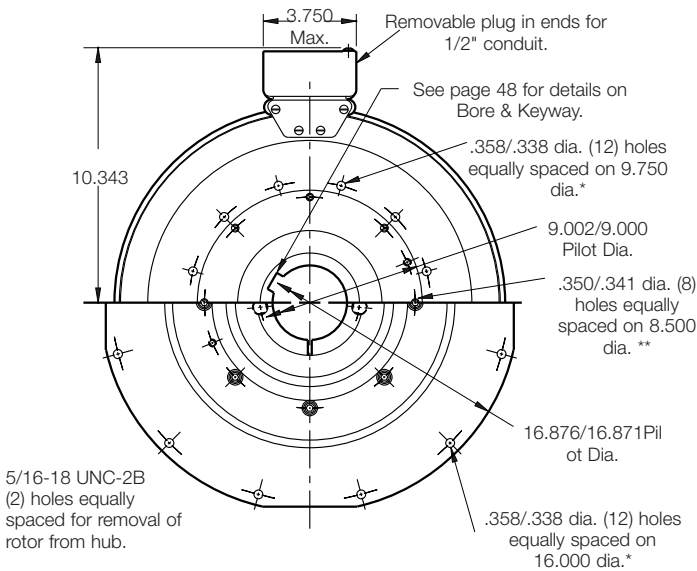

**Field View
(Inside & Outside Mounted)**

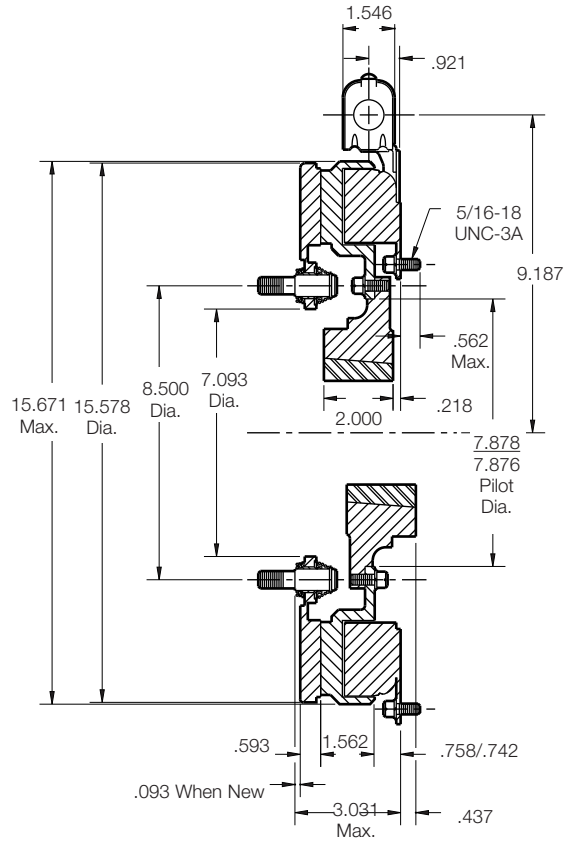

* Mounting holes are within .010 of true position relative to pilot diameter.

** Mounting holes are within .008 of true position relative to pilot diameter.

Customer Shall Maintain:

1. Concentricity of field mtg. pilot dia. with rotor mtg. shaft within .006 T.I.R.
2. Squareness of field mtg. face with rotor mtg. shaft within .006 T.I.R. measured at field mtg. bolt circle.
3. Rotor mtg. shaft concentric with armature center of rotation within .006 T.I.R.
4. Armature hub pilot dia. to be concentric with armature center of rotation within .010 T.I.R.

Shaft Size	.937 – 3.000
Static Torque	700 lb. ft.
Maximum Speed	2,000 rpm
Standard Voltage	D.C. 6, 24, 90

All dimensions are nominal unless otherwise noted.

SF-1525 Clutch Flange Mounted-Normal Duty

Drawing I-25625

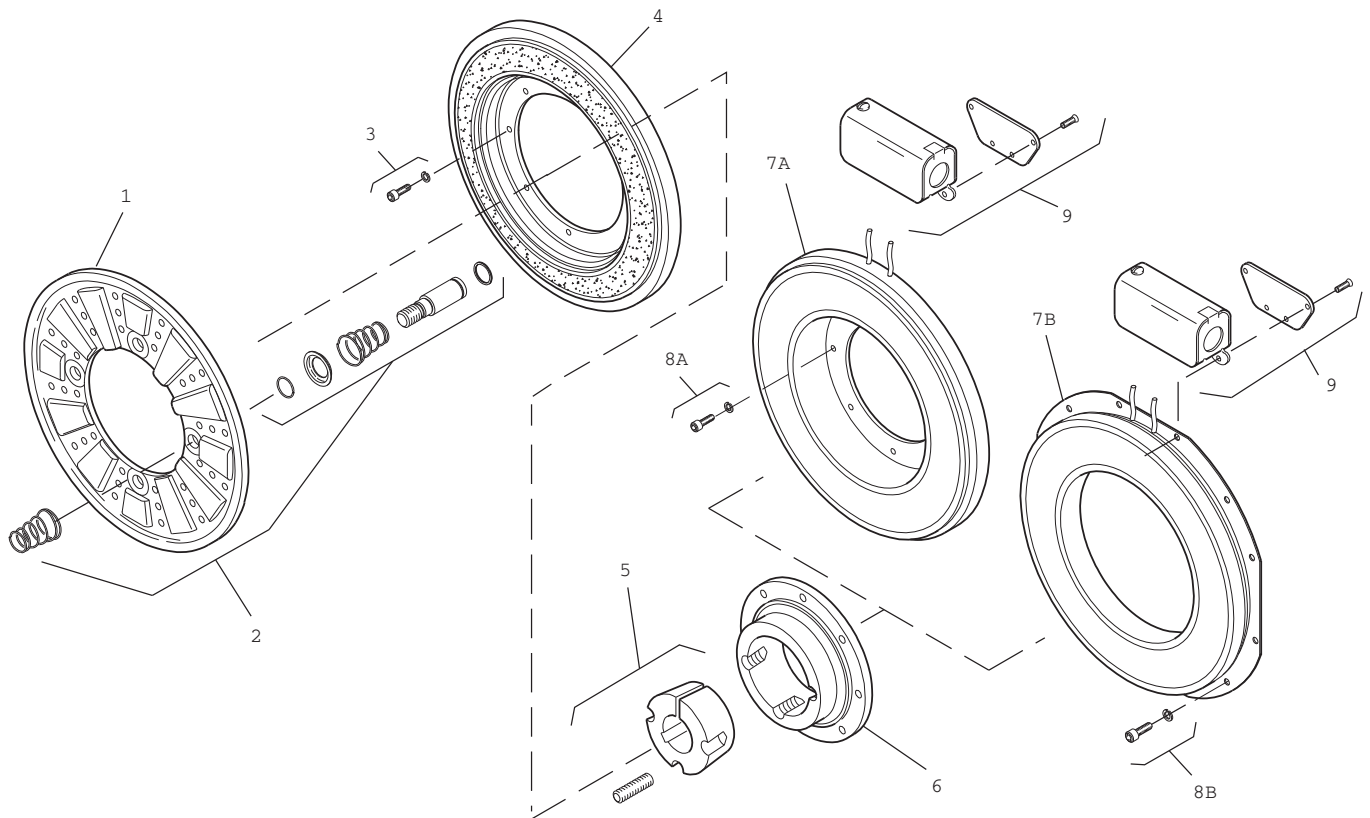

Item	Description	SF-1525, B.M. Part Number	Qty.
1	Armature	5304-111-004	1
2	Autgap Accessory	5201-101-008	4
3	Mounting Accessory	5321-101-002	2
4	Rotor		1
	Standard Friction Material	5204-751-002	
	†Optional LK Facing	5204-751-004	
5	Bushing		
	5/16" to 3" Bore	180-0223 to 180-0256	
6	Rotor Hub	540-0004	1
7A	Field - Inside Mounted		1
	6 Volt	5204-451-013	
	24 Volt	5204-451-015	
	90 Volt	5204-451-016	
7B	Field - Outside Mounted		1
	6 Volt	5204-451-055	
	24 Volt	5204-451-056	
	90 Volt	5204-451-057	
8A	Mounting Accessory - I.M.	5321-101-001	2
8B	Mounting Accessory - O.M.	5321-101-001	2
9	Conduit Box	5200-101-012	1

*See page 48 for specific part numbers. †Optional LK facing available.

How to Order:

1. Specify Bore Size for Item 5.
2. Specify Voltage for Item 7A or 7B.
3. Specify Inside Mounted for Items 7A and 8A or Outside Mounted for Items 7B and 8B.

Example:

SF-1525 Clutch per I-25625 - 90 Volt, 2" Bore, Inside Mounted.

These units, when used in conjunction with the correct Warner Electric conduit box, meet the standards of UL508 and are listed under guide card #NMTR, file #59164. These units are CSA certified under file #LR11543.

SF-1525 H.T. Clutch, Hi-Torque Flange Mounted

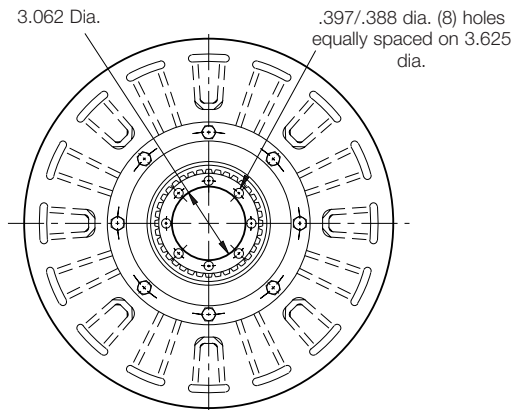

Armature View

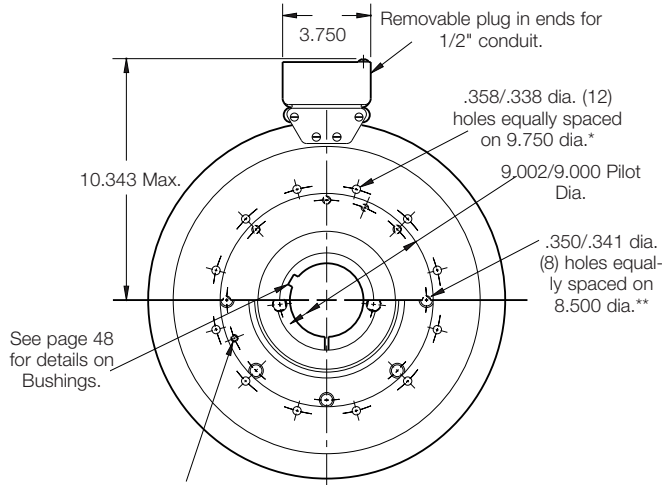

Field View

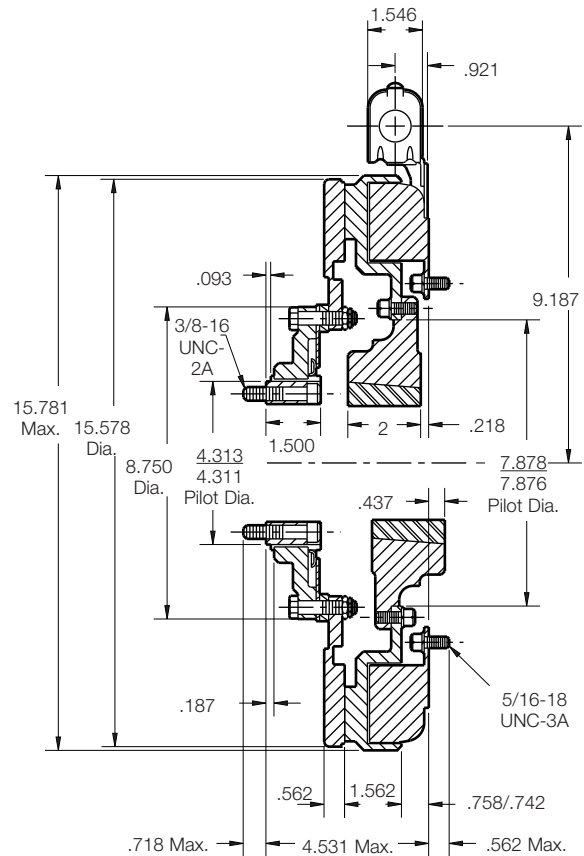

* Mounting holes are within .010 of true position relative to pilot diameter.

** Mounting holes are within .008 of true position relative to pilot diameter.

Customer Shall Maintain:

1. Concentricity of field mtg. pilot dia. with rotor mtg. shaft within .006 T.I.R.
2. Squareness of field mtg. face with rotor mtg. shaft within .006 T.I.R. measured at field mtg. bolt circle.
3. Rotor mtg. shaft concentric with armature center of rotation within .006 T.I.R.
4. Armature hub pilot dia. to be concentric with armature center of rotation within .010 T.I.R.

Shaft Size	.937- .3.000
Static Torque	1,350 lb. ft.
Maximum Speed	2,000 rpm
Standard Voltage	D.C. 6, 90

All dimensions are nominal unless otherwise noted.

SF-1525 H.T. Clutch, Hi-Torque Flange Mounted

Drawing I-25627

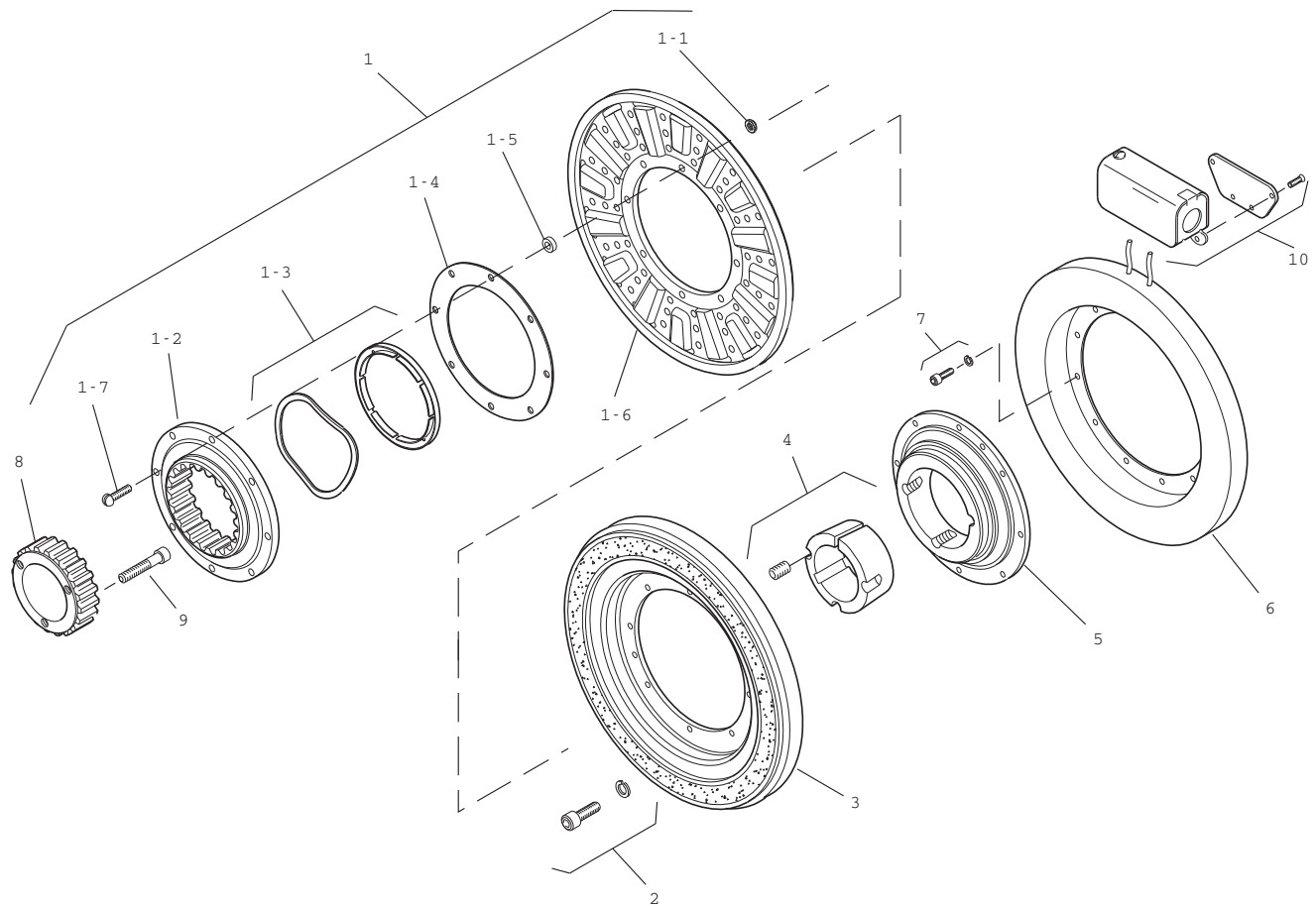

SF-1525 H.T.			
Item	Description	Part Number	Qty.
1	Armature Assembly	5204-111-004	1
1-1	Locknut	661-0004	8
1-2	Splined Adapter	104-0011	1
1-3	Autogap Accessory	5323-101-002	1
1-4	Retainer Plate	686-0003	1
1-5	Spacer	748-0333	8
1-6	Armature	5324-111-034	1
1-7	Screw	797-0342	8
2	Mounting Accessory	5321-101-002	2
3	Rotor	5204-751-001	1
4	Bushing		
	15/16" to 3" Bore	180-0223 to 180-0256*	1
5	Rotor Hub	540-0004	1
6	Field - Inside Mounted		1
	6 Volt	5204-451-005	
	90 Volt	5204-451-006	
7	Mounting Accessory - I.M.	5321-101-001	2

SF-1525 H.T.			
Item	Description	Part Number	Qty.
8	Splined Hub	540-0148	1
9	Mounting Accessory	5202-101-001	1
10	Conduit Box	5200-101-012	1

How to Order:

1. Specify Bore Size of Item 4.

Example:

SF-1525 Clutch, Hi-Torque, per I-25627 - 90 Volt, 2" Bore

These units, when used in conjunction with the correct Warner Electric conduit box, meet the standards of UL508 and are listed under guide card #NMTR, file #59164. These units are CSA certified under file #LR11543.

SF-825 Clutch Bearing Mounted-Heavy Duty

.271/.263 dia. 5 holes (hub) equally spaced on 2.015 dia. and within .003 of true position relation to 2.313/2.311 pilot dia.

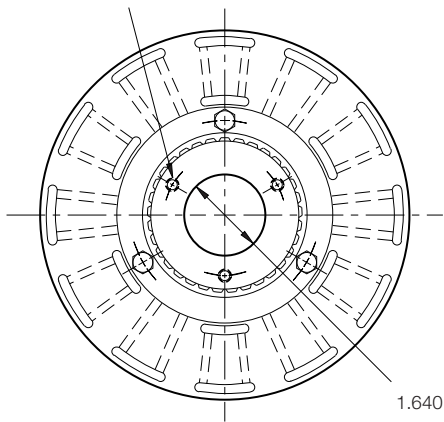

Armature View

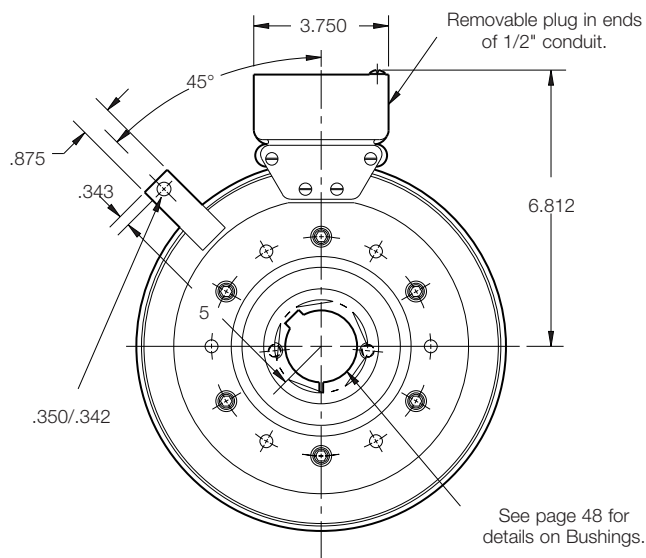

Field View

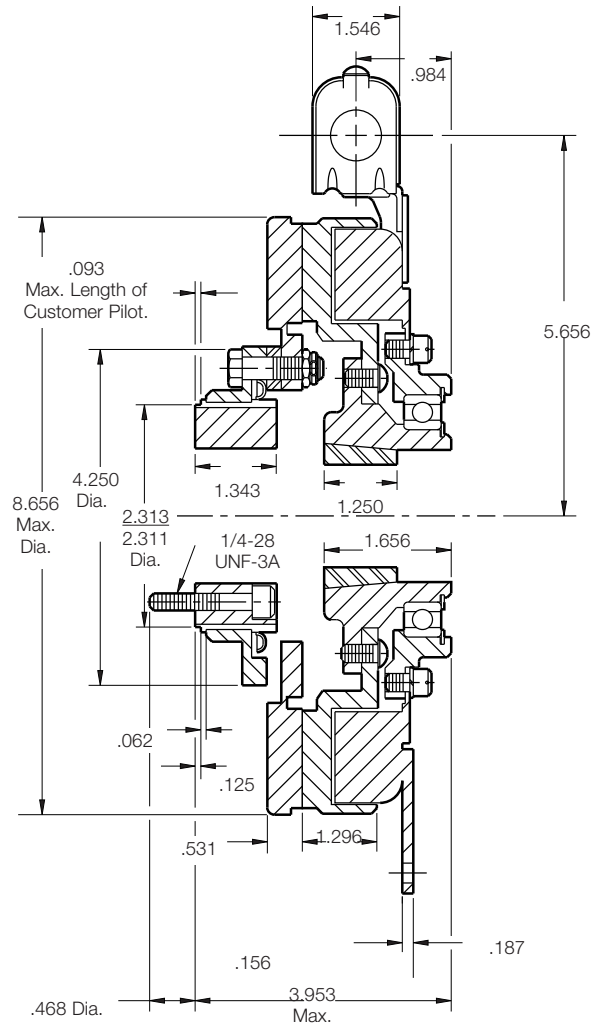

Shaft Size	.500 – 1.500
Static Torque	150 lb. ft.
Maximum Speed	3,600 rpm
Standard Voltage	D.C. 6, 24, 90

All dimensions are nominal unless otherwise noted.

Customer Shall Maintain:

1. Armature hub pilot dia. to be concentric with field and rotor mounting shaft within .010 T.I.R.
2. Angular alignment of shafts within 1/2 degree.

SF-825 Clutch Bearing Mounted-Heavy Duty

Drawing I-25573

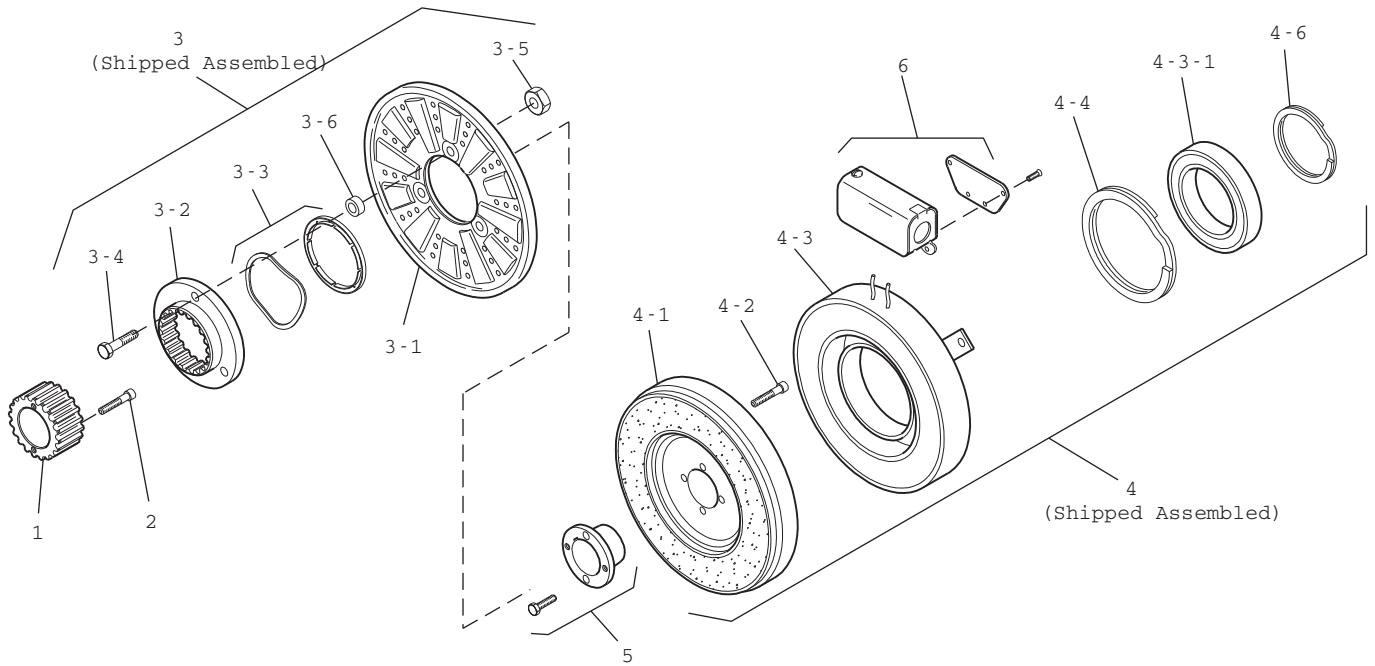

Item	Description	SF-825 B.M. Part Number	Qty.
1	Splined Hub	540-0146	1
2	Accessory, Mounting	5201-101-001	1
3	Armature & Adapter Assembly	5201-111-001	1
3-1	Armature	5321-111-022	1
3-2	Splined Adapter	104-0008	1
3-3	Autogap Accessory	5321-101-006	1
3-4	Screw	797-0341	3
3-5	Locknut	661-0004	3
3-6	Spacer	748-0333	3
4	Field & Rotor Assembly		1
	6 Volt	5201-452-002	
	24 Volt	5201-452-004	
	90 Volt	5201-452-006	
4-1	Rotor		1
	Standard Friction Material	5201-751-008	
4-2	Mounting Accessory	5201-101-005	
4-3	Field & Bearing Assembly		1
	6 Volt	5201-451-054	
	24 Volt	5201-451-056	
	90 Volt	5201-451-057	
4-4	Retainer Ring	748-0111	1
4-5	Ball Bearing	166-0142	1
4-6	Retainer Ring	748-0016	1
5	Bushing*	180-0002 to 180-0018	1
6	Conduit Box	5200-101-012	1

*See page 48 for specific part numbers.

How to Order:

1. Specify Bore Size for Item 5.
2. Specify Voltage for Item 4.

Example:

SF-825 Clutch per I-25573 - 90 Volt, 1" Bore

These units, when used in conjunction with the correct Warner Electric conduit box, meet the standards of UL508 and are listed under guide card #NMTR, file #59164. These units are CSA certified under file #LR11543.

SF-1000 Clutch Bearing Mounted—Heavy Duty

.397/.388 dia. 3 holes (hub) equally spaced on 3.187 dia. and within .003 of true position relation to 4.001/3.999 pilot dia.

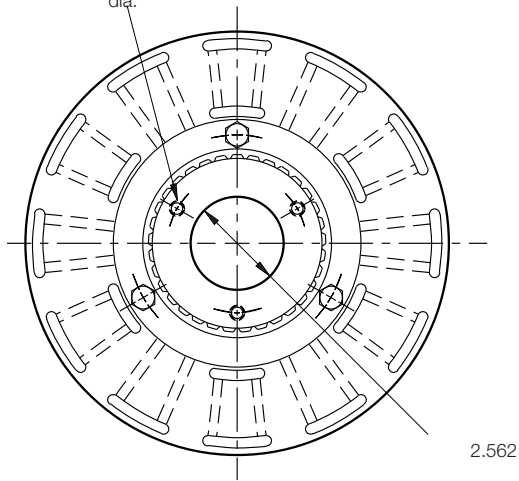

Armature View

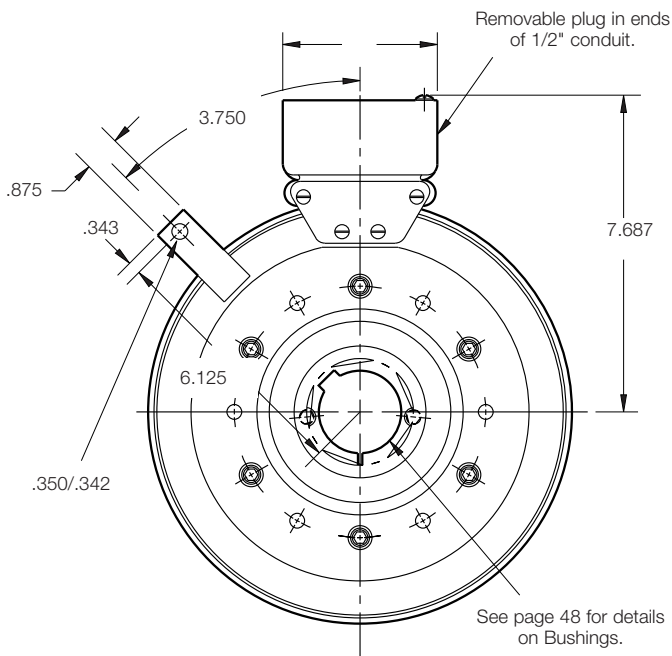

Field View

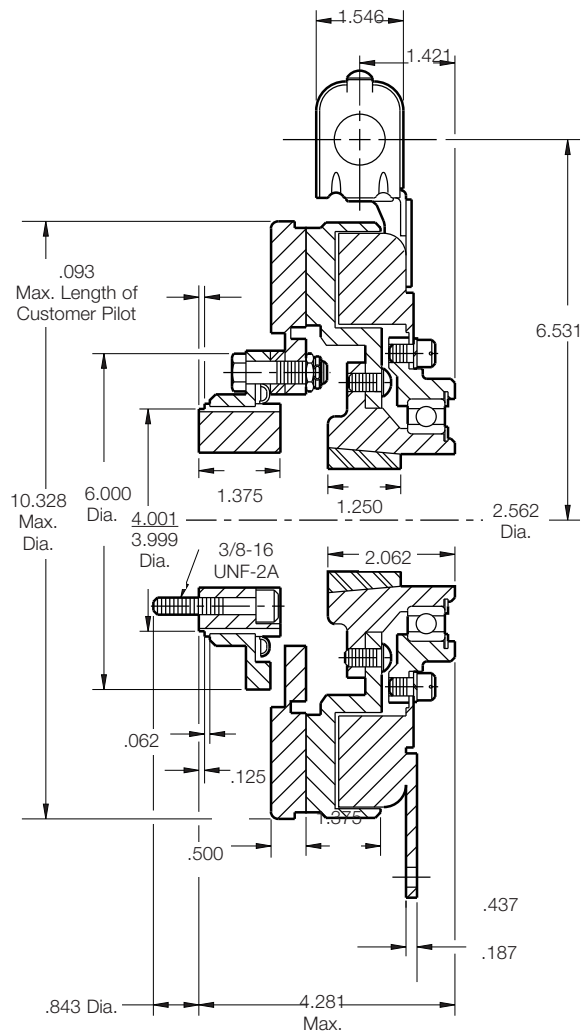

Shaft Size	.500 – 2.000
Static Torque	240 lb. ft.
Maximum Speed	2,500 rpm
Standard Voltage	D.C. 6, 24, 90

All dimensions are nominal unless otherwise noted.

Customer Shall Maintain:

1. Armature hub pilot dia. to be concentric with field and rotor mounting shaft within .010 T.I.R.
2. Angular alignment of shafts within 1/2 degree.

SF-1000 Clutch Bearing Mounted-Heavy Duty

Drawing I-25597

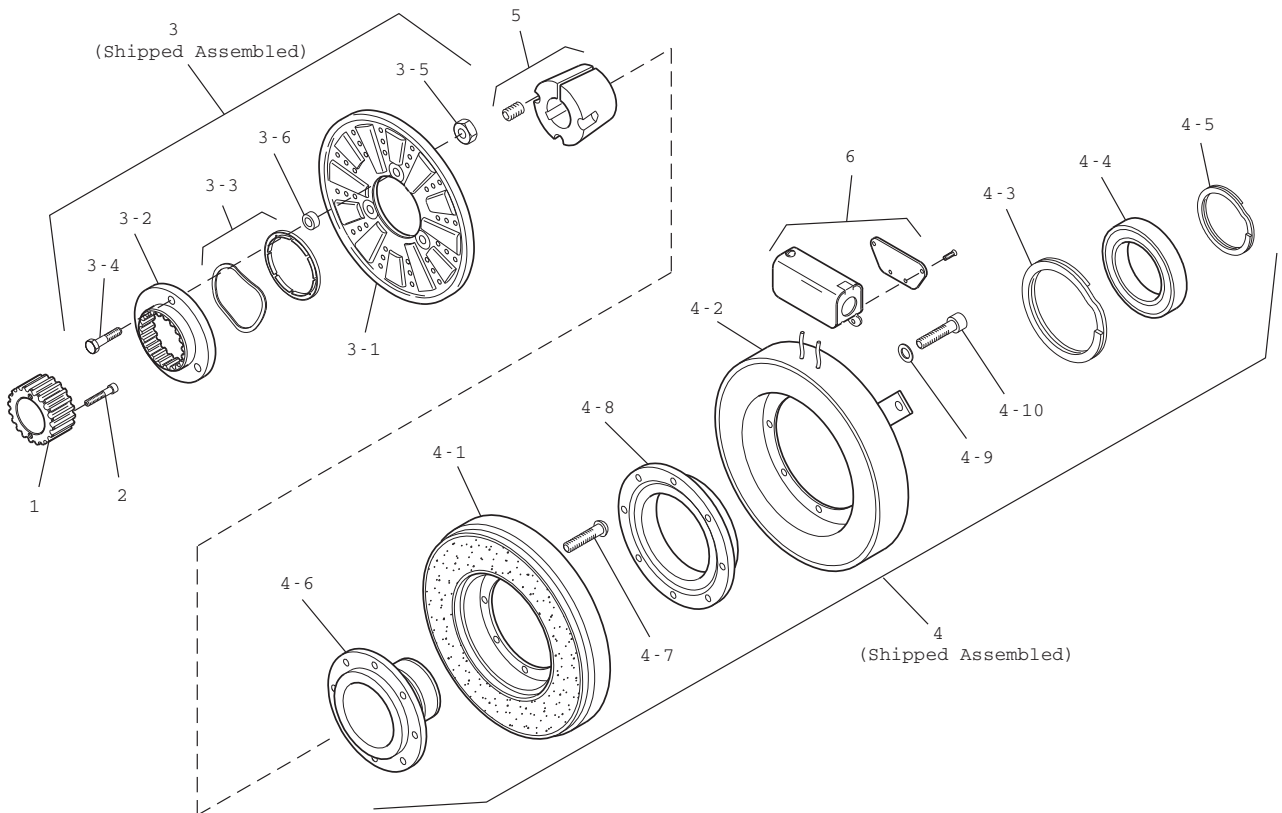

Item	Description	SF-1000 B.M. Part Number	Qty.
1	Splined Hub	540-0147	1
2	Accessory, Mounting	5202-101-001	1
3	Armature & Adapter Assembly	5202-111-001	1
3-1	Armature	5322-111-036	1
3-2	Splined Adapter	104-0009	1
3-3	Autogap Accessory	5322-101-004	1
3-4	Screw	797-0341	3
3-5	Locknut	661-0004	3
3-6	Spacer	748-0333	3
4	Field & Rotor Assembly		1
	6 Volt	5202-452-012	
	24 Volt	5202-452-014	
	90 Volt	5202-452-015	
4-1	Rotor		1
	Standard Friction Material	5202-751-003	
	†Optional LK Facing	5202-751-007	
4-2	Mounting Accessory		
4-3	Field		1
	6 Volt	5202-451-040	
	24 Volt	5202-451-042	
	90 Volt	5202-451-043	
4-4	Retainer Ring	748-0116	1
4-5	Ball Bearing	166-1046	1
4-6	Retainer Ring	748-0582	1
4-7	Rotor Hub	540-1300	1
4-8	Buttonhead Capscrew	797-1261	6

Item	Description	SF-1000 B.M. Part Number	Qty.
4-9	Ring Adapter	748-1047	1
4-10	Lockwasher	950-0359	6
4-11	Socket Head Capscrew	797-0422	6
5	Bushing*	180-0155 to 180-0179	1
6	Conduit Box	5200-101-012	1

*See page 48 for specific part numbers. †Optional LK facing available.

How to Order:

1. Specify Bore Size for Item 5.
2. Specify Voltage for Item 4.

Example:

SF-1000 Clutch per I-25597 - 90 Volt, 1" Bore

These units, when used in conjunction with the correct Warner Electric conduit box, meet the standards of UL508 and are listed under guide card #NMTR, file #59164. These units are CSA certified under file #LR11543.

SF-1225 Clutch Bearing Mounted-Heavy Duty

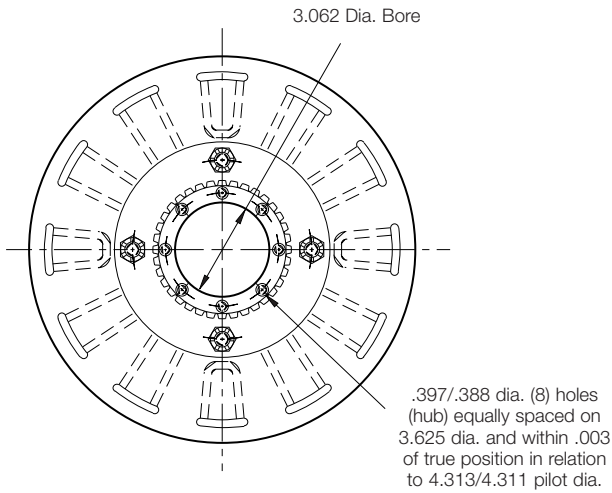

Armature View

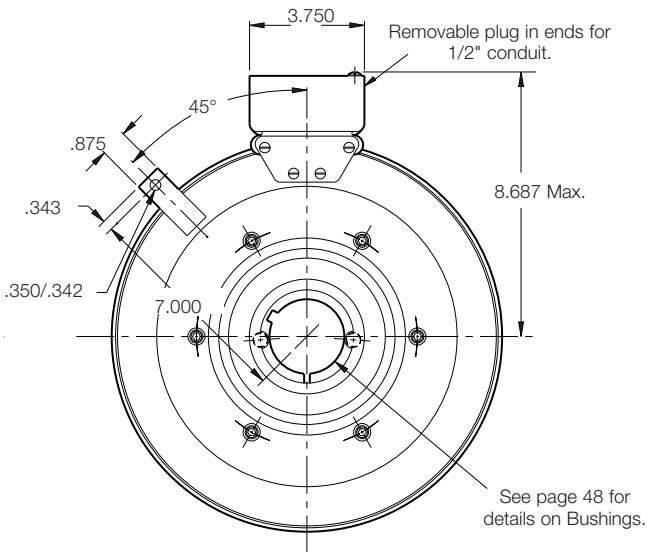
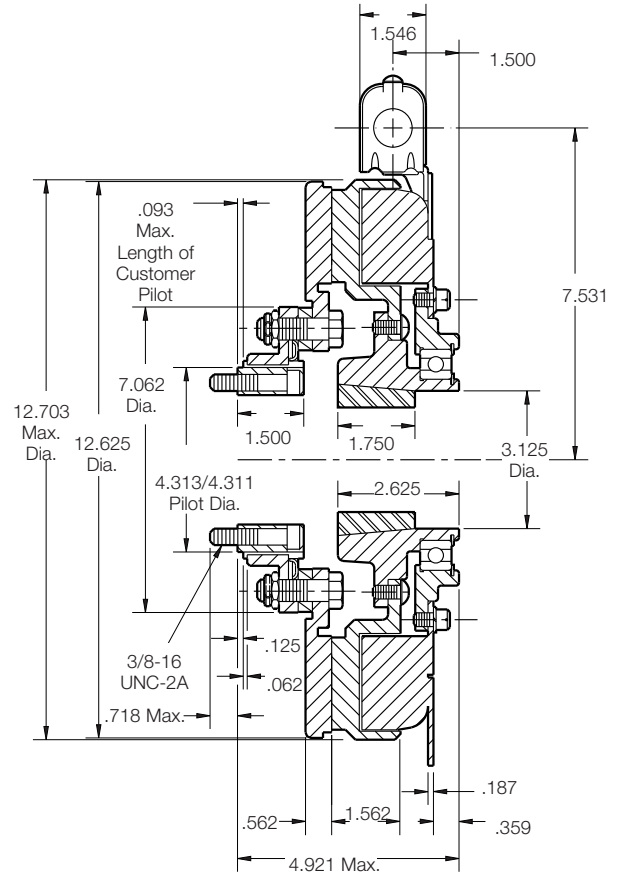

Field View

Shaft Size	.500 – 2.500
Static Torque	465 lb. ft.
Maximum Speed	2,200 rpm
Standard Voltage	D.C. 6, 24, 90

All dimensions are nominal unless otherwise noted.

Customer Shall Maintain:

1. Armature hub pilot dia. to be concentric with field and rotor mounting shaft within .010 T.I.R.
2. Angular alignment of shafts within 1/2 degree.

SF-1225 Clutch Bearing Mounted-Heavy Duty

Drawing I-25622

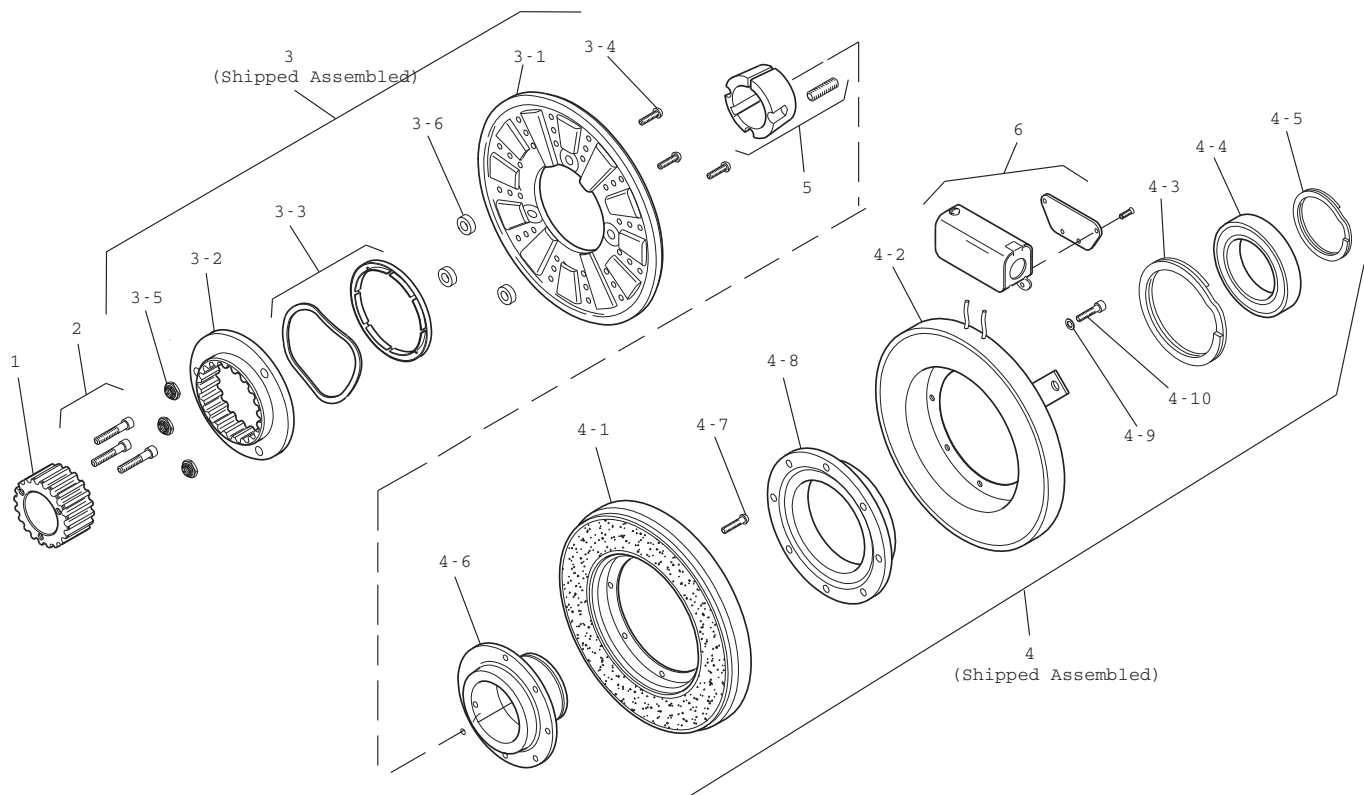

Item	Description	SF-1225, B.M. Part Number	Qty.
1	Splined Hub	540-0148	1
2	Accessory Mounting	5202-101-001	1
3	Armature & Adapter Assembly	5203-111-001	1
3-1	Armature	5323-111-034	1
3-2	Splined Adapter	104-0010	1
3-3	Autogap Accessory	5323-101-002	1
3-4	Screw	797-0356	4
3-5	Locknut	661-0005	4
3-6	Spacer	266-0004	4
4	Field & Rotor Assembly		1
	6 Volt	5203-452-009	
	24 Volt	5203-452-011	
	90 Volt	5203-452-012	1
4-1	Rotor		1
	Standard Friction Material	5203-751-001	
	†Optional LK Facing	5203-751-004	
4-2	Field		1
	6 Volt	5203-451-034	
	24 Volt	5203-451-036	
	90 Volt	5203-451-037	
4-3	Retainer Ring	748-0119	1
4-4	Ball Bearing	166-1047	1
4-5	Retainer Ring	748-0011	1

Item	Description	SF-1225, B.M. Part Number	Qty.
4-6	Rotor Hub	540-1304	1
4-7	Buttonhead Screw	797-1261	8
4-8	Ring Adapter	748-0591	1
4-9	Lockwasher	950-0359	6
4-10	Sockethead Screw	797-0424	6
5	Bushing*	180-0185 to 180-0217	1
6	Conduit Box	5200-101-012	1

*See page 48 for specific part numbers. †Optional LK facing available.

How to Order:

1. Specify Bore Size for Item 5.
2. Specify Voltage for Item 4.

Example:

SF-1225 Clutch per I-25622 - 90 Volt, 1" Bore

These units, when used in conjunction with the correct Warner Electric conduit box, meet the standards of UL508 and are listed under guide card #NMTR, file #59164. These units are CSA certified under file #LR11543.

SF-1525 Clutch Bearing Mounted—Heavy Duty

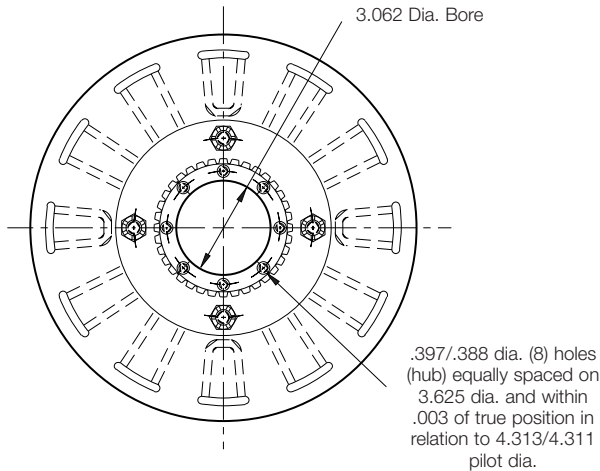

Armature View

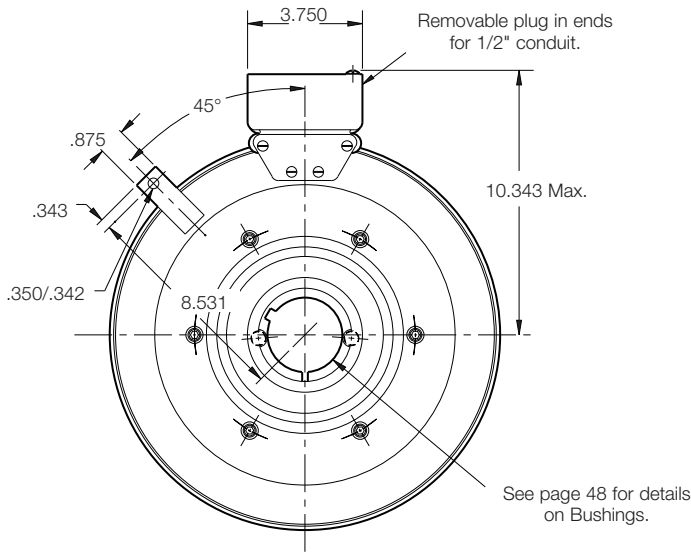

Field View

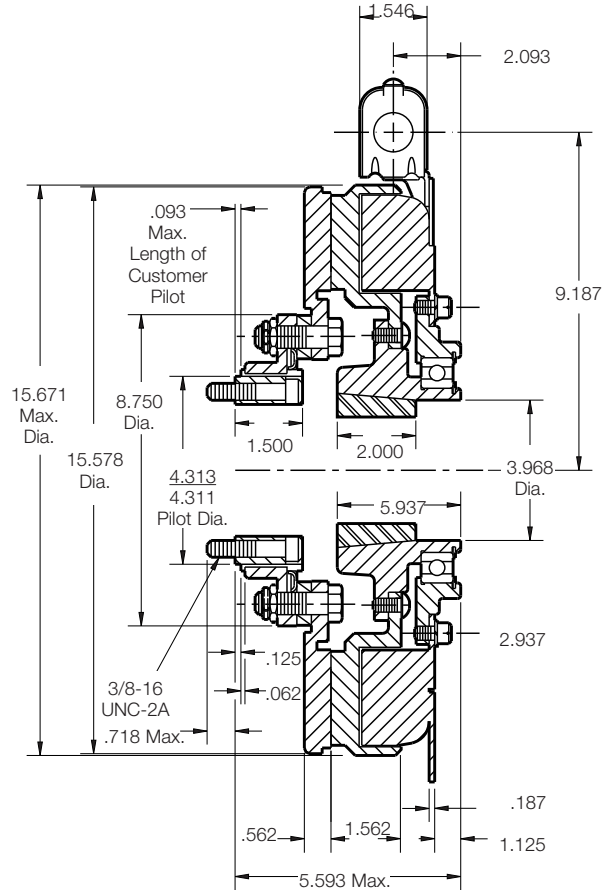

Shaft Size	.937 – 3.000
Static Torque	700 lb. ft.
Maximum Speed	1,800 rpm
Standard Voltage	D.C. 6, 24, 90

All dimensions are nominal unless otherwise noted.

Customer Shall Maintain:

1. Armature hub pilot dia. to be concentric with field and rotor mounting shaft within .010 T.I.R.
2. Angular alignment of shafts within 1/2 degree.

SF-1525 Clutch Bearing Mounted-Heavy Duty

Drawing I-25640

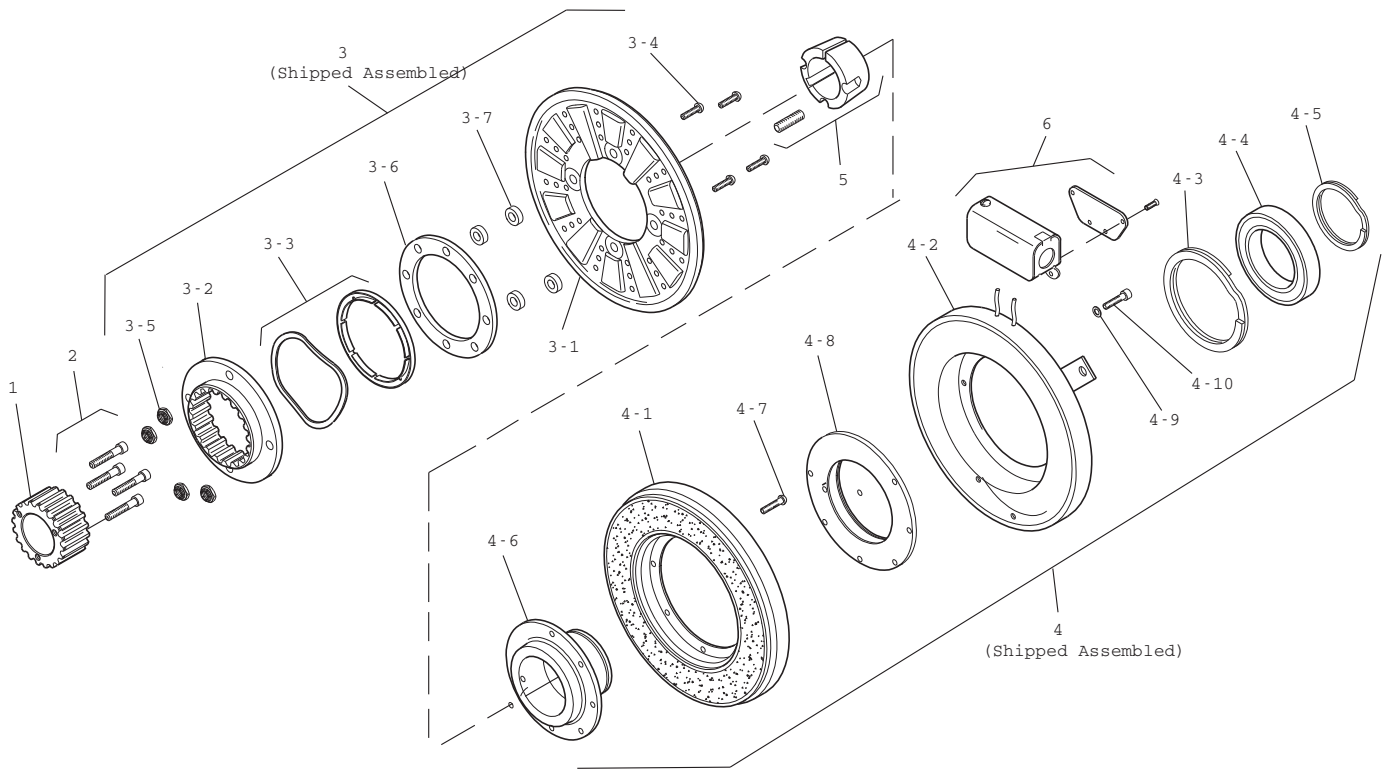

Item	Description	SF-1525, B.M. Part Number	Qty.
1	Splined Hub	540-0148	1
2	Accessory Mounting	5202-101-001	1
3	Armature & Adapter Assembly	5204-111-004	1
3-1	Armature	5324-111-034	1
3-2	Splined Adapter	104-0011	1
3-3	Autogap Accessory	5324-101-002	1
3-4	Screw	797-0342	8
3-5	Locknut	661-0004	8
3-6	Retainer Plate	686-0003	
3-7	Spacer	748-0333	8
4	Field & Rotor Assembly		1
	6 Volt	5204-452-009	
	24 Volt	5204-452-011	
	90 Volt	5204-452-012	
4-1	Rotor		1
	Standard Friction Material	5204-751-002	
	†Optional LK Facing	5204-751-004	
4-2	Field		1
	6 Volt	5204-451-084	
	24 Volt	5204-451-086	
	90 Volt	5204-451-087	
4-3	Retainer Ring	748-0114	1
4-4	Ball Bearing	166-0163	1

Item	Description	SF-1525, B.M. Part Number	Qty.
4-5	Retainer Ring	748-0583	1
4-6	Rotor Hub	540-1306	1
4-7	Buttonhead Screw	797-1261	8
4-8	Ring Adapter	748-1048	1
4-9	Lockwasher	950-0359	6
4-10	Sockethead Screw	797-0424	6
5	Bushing*	180-0223 to 180-0256*	1
6	Conduit Box	5200-101-012	1

*See page 48 for specific part numbers. †Optional LK facing a

How to Order:

1. Specify Bore Size for Item 5.
2. Specify Voltage for Item 4.

Example:

SF-1525 Clutch per I-25640 - 90 Volt, 1" Bore

These units, when used in conjunction with the correct Warner Electric conduit box, meet the standards of UL508 and are listed under guide card #NMTR, file #59164. These units are CSA certified under file #LR11543.

SF-1525 H.T. Clutch, Hi-Torque Bearing Mounted

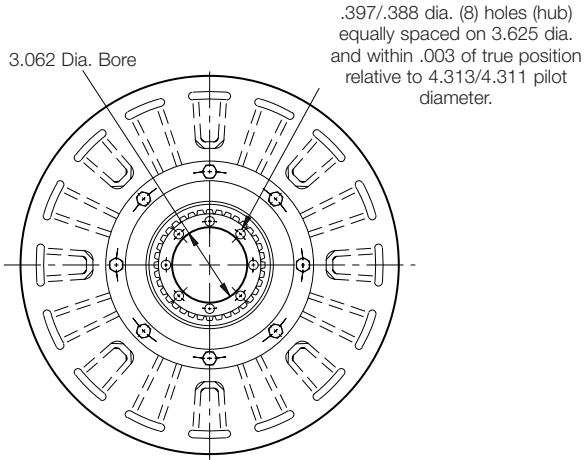

Armature View

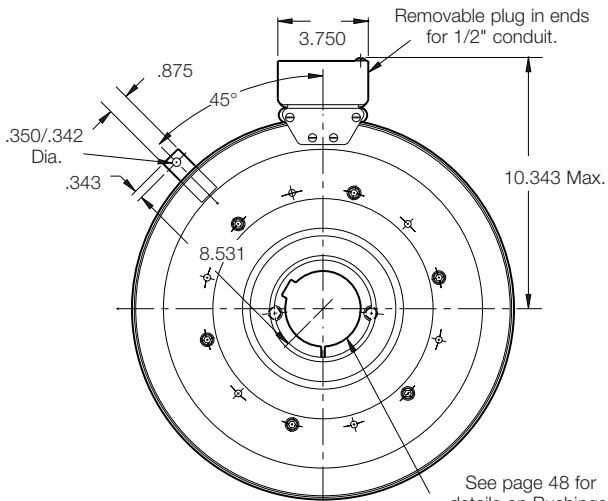

Field View

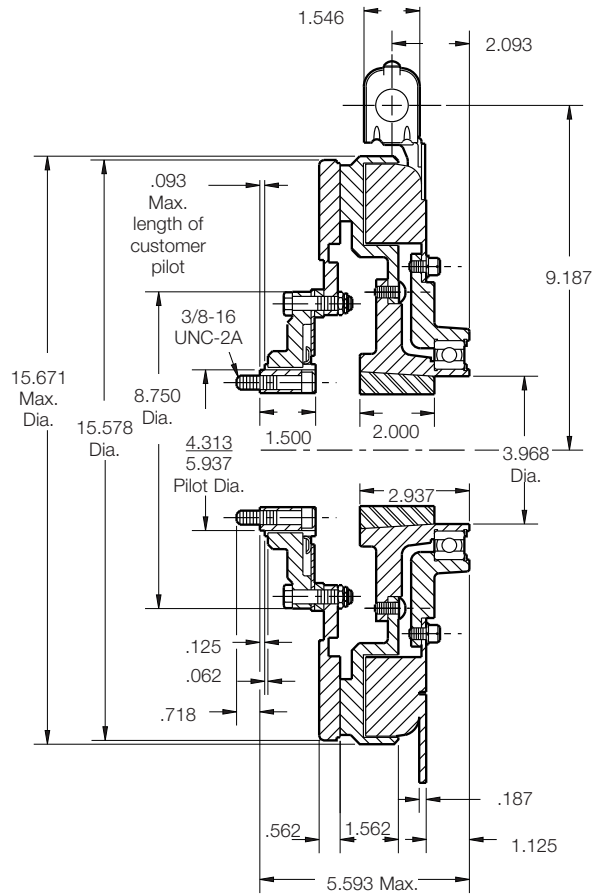

Shaft Size	.937- 3.000
Static Torque	1,350 lb. ft.
Maximum Speed	1,800 rpm
Standard Voltage	D.C. 90

All dimensions are nominal unless otherwise noted.

Customer Shall Maintain:

1. Armature hub pilot dia. to be concentric with field and rotor mounting shaft within .010 T.I.R.
2. Angular alignment of shafts within 1/2 degree.

SF-1525 H.T. Clutch, Hi-Torque Bearing Mounted

Drawing I-25643

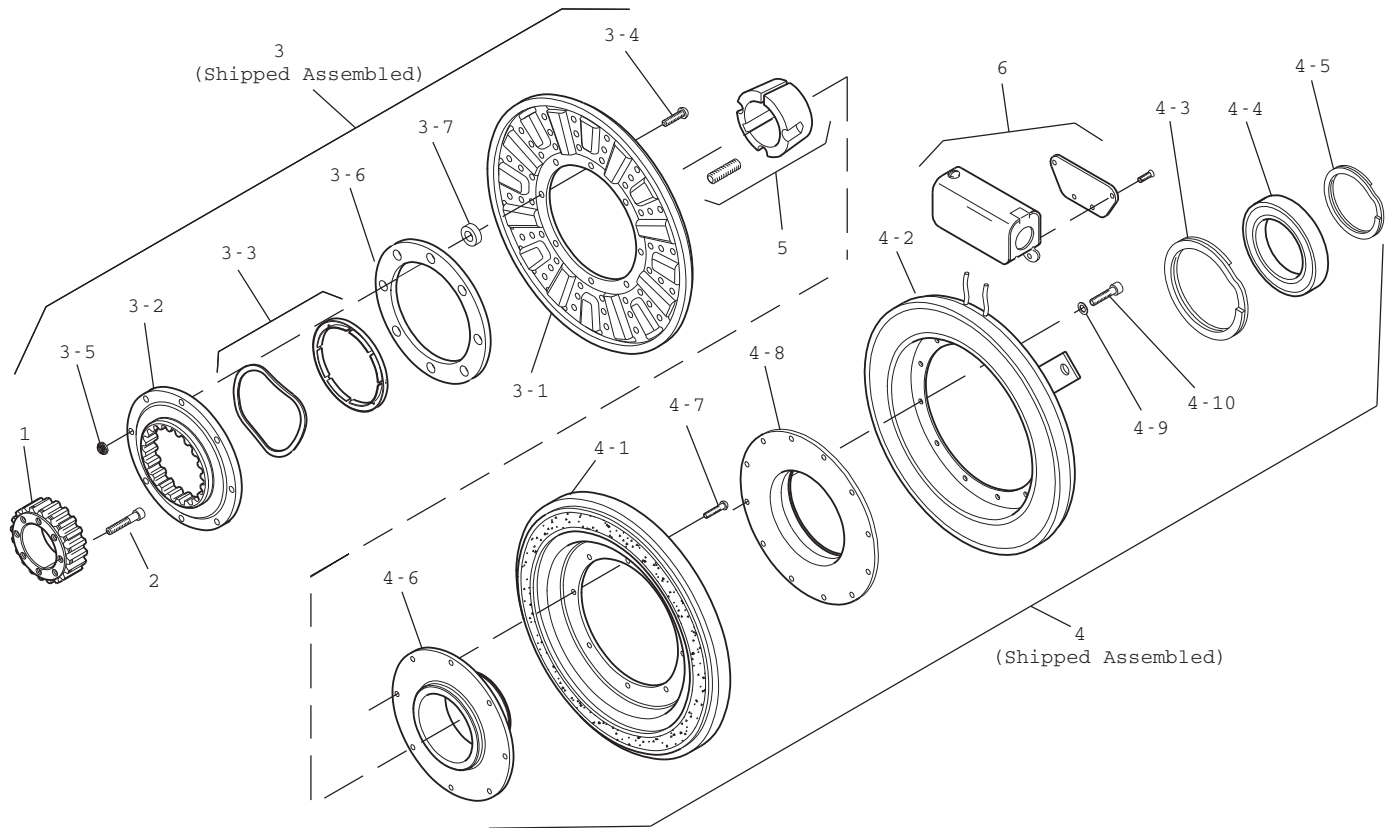

SF-1525 H.T. B.M.			
Item	Description	Part Number	Qty.
1	Splined Hub	540-0148	1
2	Accessory, Mounting	5202-101-001	1
3	Armature & Adapter Assembly	5204-111-004	1
3-1	Armature	5324-111-034	1
3-2	Splined Adapter	104-0011	1
3-3	Autogap Accessory	5323-101-002	1
3-4	Screw	797-0342	8
3-5	Locknut	661-0004	8
3-6	Retainer Plate	686-0003	1
3-7	Spacer	748-0333	8
4	Field & Rotor Assembly		1
	90 Volt	5204-452-015	
4-1	Rotor	5204-751-001	1
4-2	Field		1
	90 Volt	5204-451-090	
4-3	Retainer Ring	748-0114	1
4-4	Ball Bearing	166-0163	1
4-5	Retainer Ring	748-0583	1
4-6	Rotor Hub	540-1306	1
4-7	Buttonhead Screw	797-1261	8
4-8	Ring Adapter	748-1048	1

SF-1525 H.T. B.M.			
Item	Description	Part Number	Qty.
4-9	Lockwasher	950-0359	6
4-10	Sockethead Screw	797-0424	6
5	Bushing*	180-0223 to 180-0256	1
6	Conduit Box	5200-101-012	1

*See page 48 for specific part numbers.

How to Order:

1. Specify Bore Size for Item 5.
2. Specify Voltage for Item 4.

Example:

SF-1225 Clutch Hi-Torque per I-25643 - 90 Volt, 1" Bore

These units, when used in conjunction with the correct Warner Electric conduit box, meet the standards of UL508 and are listed under guide card #NMTR, file #59164. These units are CSA certified under file #LR11543.

SF-825 Clutch Flange Mounted—Heavy Duty

.271/.263 dia. 5 holes (hub) equally spaced on 2.015 dia. Mounting holes are within .003 of true position relative to pilot dia.

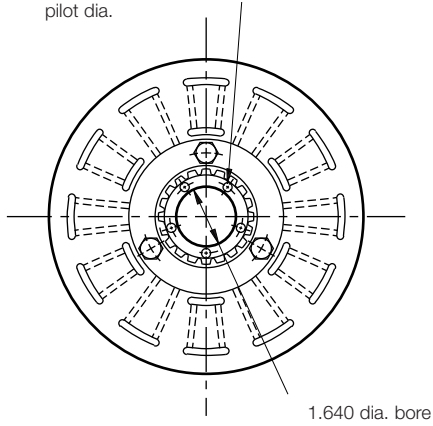

Armature View

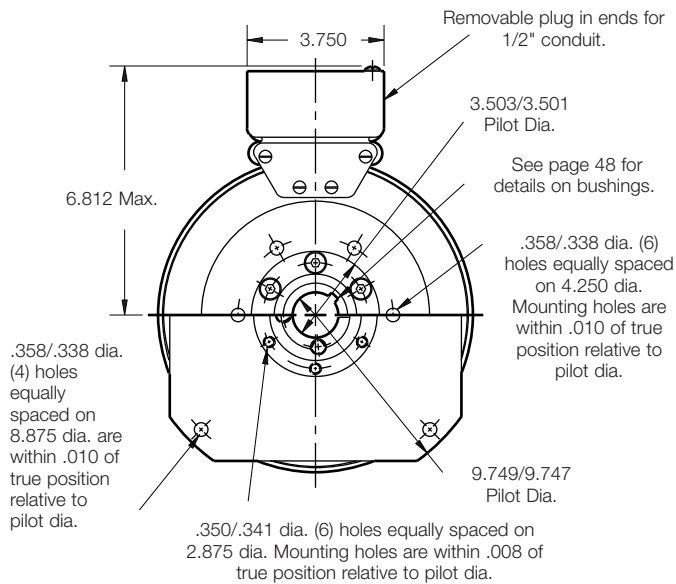

Field View
(Inside & Outside Mounted)

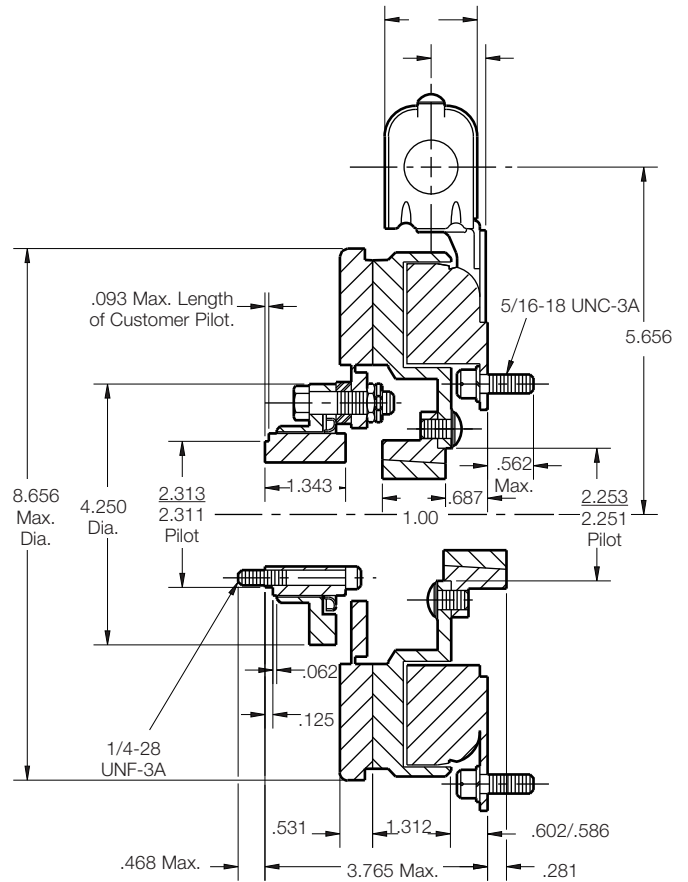

Shaft Size	.500 – 1.250
Static Torque	125 lb. ft.
Maximum Speed	4,000 rpm
Standard Voltage	D.C. 6, 24, 90

All dimensions are nominal unless otherwise noted.

Customer Shall Maintain:

1. Concentricity of field mounting pilot dia. with rotor mounting shaft within .006 T.I.R.
2. Squareness of field mounting face with shaft within .006 T.I.R. measured at field mounting bolt circle.
3. Rotor mounting shaft concentric with armature hub pilot dia. within .010 T.I.R.

SF-825 Clutch Flange Mounted-Heavy Duty

Drawing I-25561

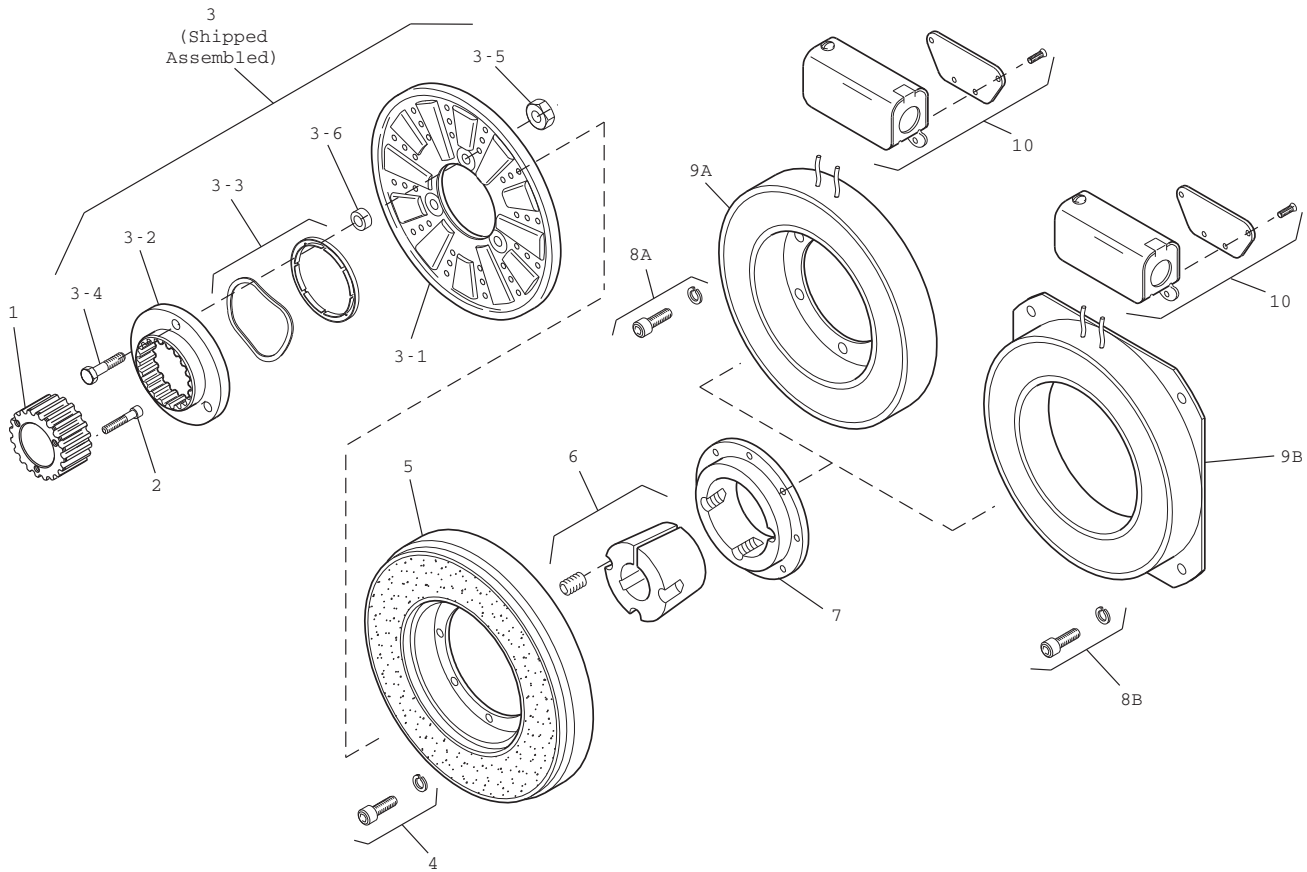

Item	Description	SF-825, F.M. Part Number	Qty.
1	Splined Hub	540-0146	1
2	Mounting Accessory	5201-101-001	1
3	Armature & Splined Adapter	5201-111-001	1
3-1	Armature	5321-111-022	1
3-2	Splined Adapter	104-0008	1
3-3	Autogap Accessory	5321-101-006	1
3-4	Screw	797-0341	3
3-5	Locknut	661-0004	3
3-6	Spacer	748-0333	3
4	Mounting Accessory	5201-101-007	1
5	Rotor		1
	Standard Friction Material	5201-751-003	
	†Optional LK Facing	5201-751-007	
6	Bushing, Taperlock*	180-0101 to 180-0113	1
7	Rotor Hub	540-0013	1
8A	Mounting Accessory, I.M.	5321-101-001	1
8B	Mounting Accessory, O.M.	5321-101-002	1
9A	Field, Inside Mounted		1
	6 Volt	5201-451-006	
	24 Volt	5201-451-008	
	90 Volt	5201-451-010	
9B	Field, Outside Mounted		1
	6 Volt	5201-451-014	
	24 Volt	5201-451-016	
	90 Volt	5201-451-018	
10	Conduit Box	5200-101-012	1

*See page 48 for specific part numbers. †Optional LK facing available.

How to Order:

1. Specify Bore Size for Item 6.
2. Specify Voltage for Item 9A or 9B.
3. Specify Inside Mounted for Items 9A and 10A or Outside Mounted for Items 9B and 10B.

Example:

SF-825 Clutch Coupling, Heavy Duty, per I-25561 - 90 Volt, Inside Mounted, 1" Bore (Item 6)

These units, when used in conjunction with the correct Warner Electric conduit box, meet the standards of UL508 and are listed under guide card #NMTR, file #59164. These units are CSA certified under file #LR11543

SF-1000 Clutch Flange Mounted—Heavy Duty

.397/.388 dia. 3 holes (hub) equally spaced on 3.187 dia. Mounting holes are within .003 of true position relative to pilot dia.

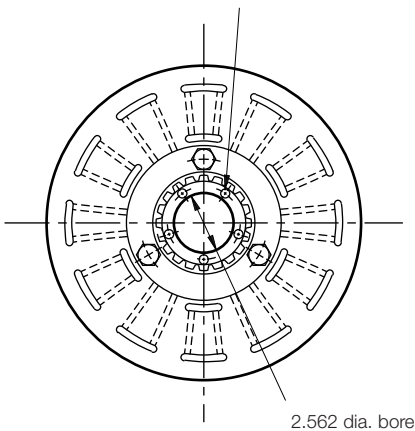

Armature View

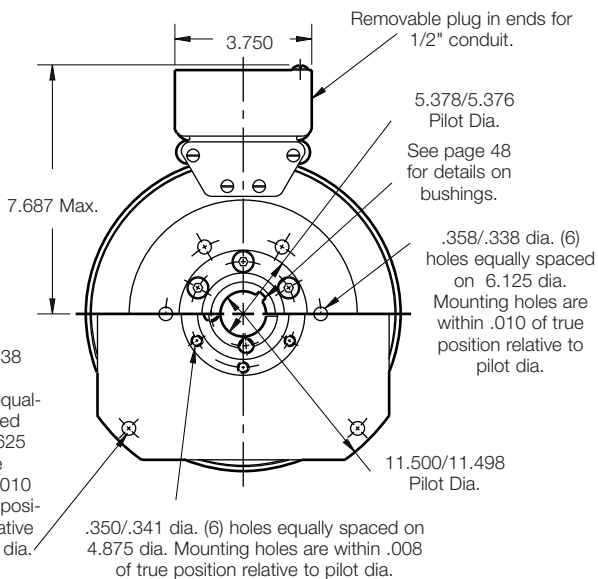
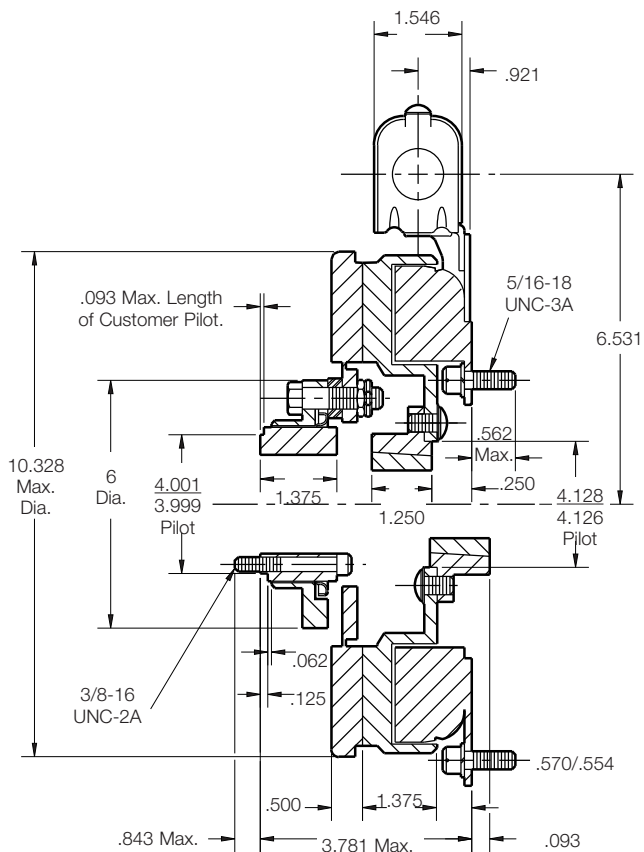

Field View
(Inside & Outside Mounted)

Customer Shall Maintain:

1. Concentricity of field mounting pilot dia. with rotor mounting shaft within .006 T.I.R.
2. Squareness of field mounting face with shaft within .006 T.I.R. measured at field mounting bolt circle.
3. Rotor mounting shaft concentric with armature hub pilot dia. within .010 T.I.R.

Shaft Size	.500 – 2.000
Static Torque	240 lb. ft.
Maximum Speed	3,600 rpm
Standard Voltage	D.C. 6, 24, 90

All dimensions are nominal unless otherwise noted.

SF-1000 Clutch Flange Mounted-Heavy Duty

Drawing I-25581

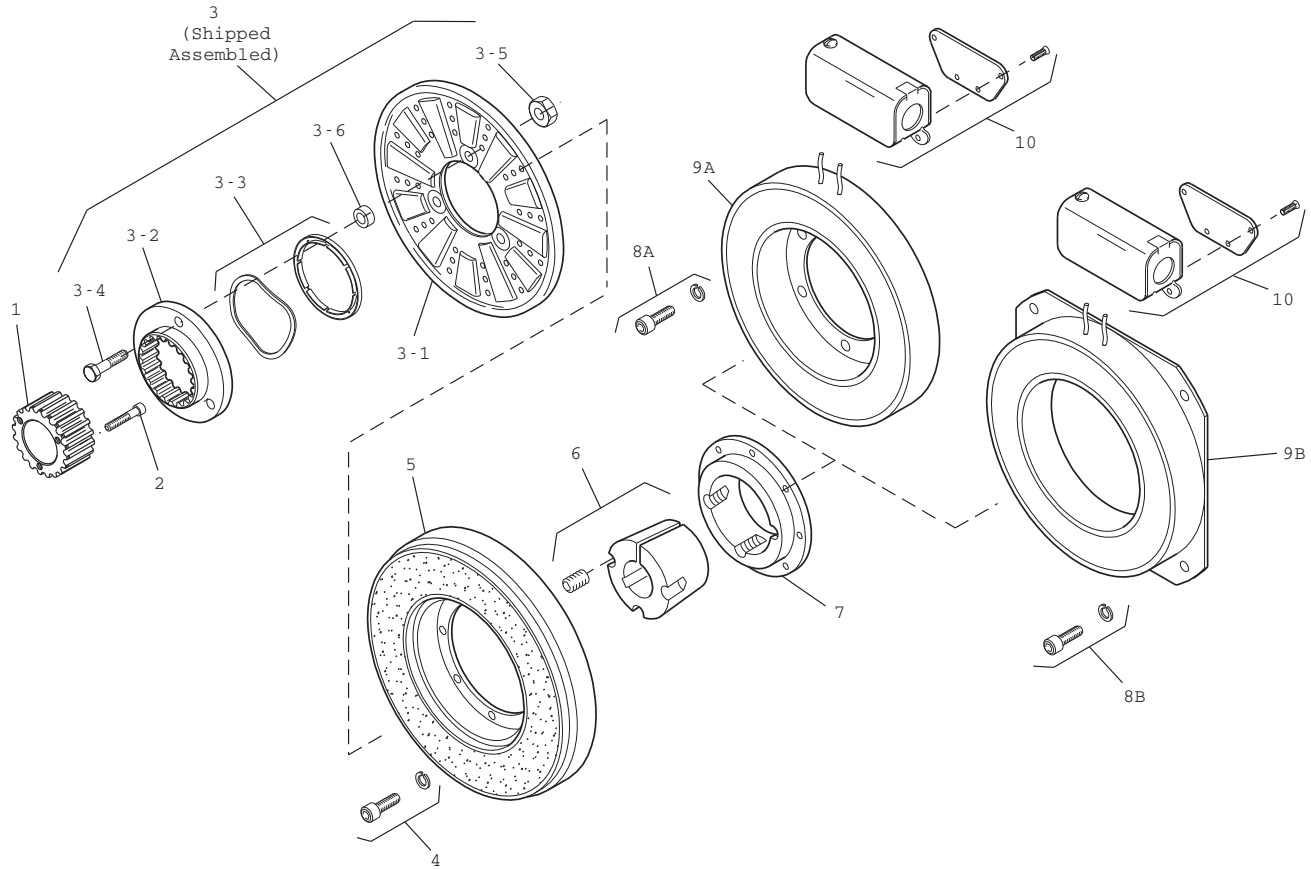

SF-1000, F.M.			
Item	Description	Part Number	Qty.
1	Splined Hub	540-0147	1
2	Mounting Accessory	5202-101-001	1
3	Armature & Splined Adapter	5202-111-001	1
3-1	Armature	5322-111-036	1
3-2	Splined Adapter	104-0009	1
3-3	Autogap Accessory	5322-101-004	1
3-4	Screw	797-0341	3
3-5	Locknut	661-0004	3
3-6	Spacer	748-0333	3
4	Mounting Accessory	5202-101-007	1
5	Rotor		1
	Standard Friction Material	5202-751-003	
	†Optional LK Facing	5202-751-007	
6	Bushing, Taperlock*	180-0155 to 180-0179	1
7	Rotor Hub	540-0315	1
8A	Mounting Accessory, I.M.	5321-101-001	1
8B	Mounting Accessory, O.M.	5321-101-002	2
9A	Field, Inside Mounted		1
	6 Volt	5202-451-004	
	24 Volt	5202-451-006	
	90 Volt	5202-451-007	
9B	Field, Outside Mounted		1
	6 Volt	5202-451-011	
	24 Volt	5202-451-013	
	90 Volt	5202-451-014	
10	Conduit Box	5200-101-012	1

*See page 48 for specific part numbers. †Optional LK facing available.

How to Order:

1. Specify Bore Size for Item 6.
2. Specify Voltage for Item 9A or 9B.
3. Specify Inside Mounted for Items 9A and 10A or Outside Mounted for Items 9B and 10B.

Example:

SF-1000 Clutch Coupling, Heavy Duty per I-25581 - 90 Volt, Inside Mounted, 1-1/4" Bore (Item 6)

These units, when used in conjunction with the correct Warner Electric conduit box, meet the standards of UL508 and are listed under guide card #NMTR, file #59164. These units are CSA certified under file #LR11543

SF-1225 Clutch Flange Mounted—Heavy Duty

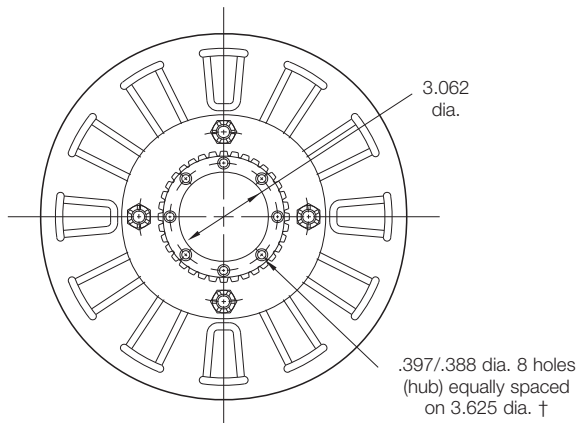

Armature View

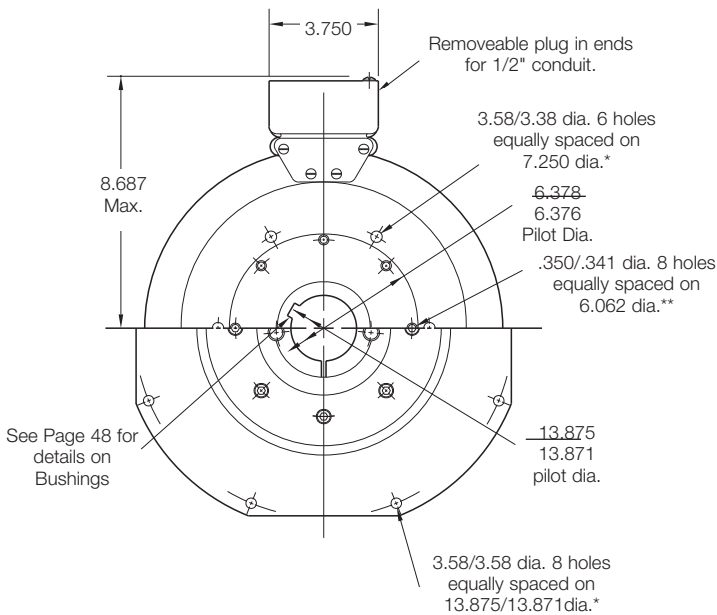

Field View
(Inside & Outside Mounted)

See Page 48 for details on Bushings

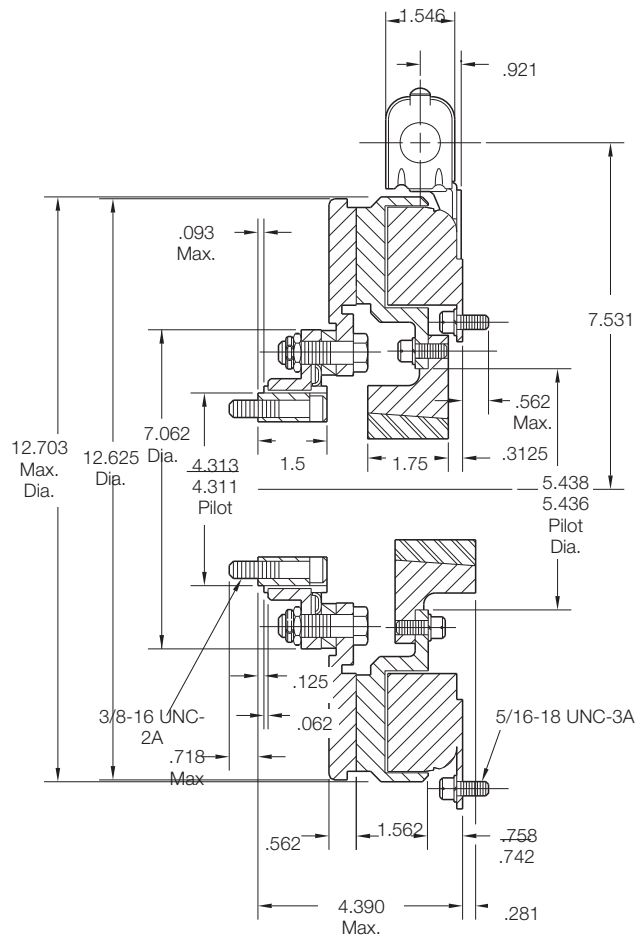

* Mounting holes are within .010 of true position relative to pilot diameter.

** Mounting holes are within .008 of true position relative to pilot diameter.

† Mounting holes are within .003 of true position relative to pilot diameter.

Customer Shall Maintain:

1. Concentricity of field mounting pilot dia. with rotor mounting shaft within .006 T.I.R.
2. Squareness of field mounting face with shaft within .006 T.I.R. measured at field mounting bolt circle.
3. Armature hub pilot diameter to be concentric with rotor mounting shaft within .010 T.I.R.

Shaft Size	.500 – 2.500
Static Torque	465 lb. ft.
Maximum Speed	3,000 rpm
Standard Voltage	D.C. 6, 24, 90

All dimensions are nominal unless otherwise noted.

SF-1225 Clutch Flange Mounted—Heavy Duty

Drawing I-25601

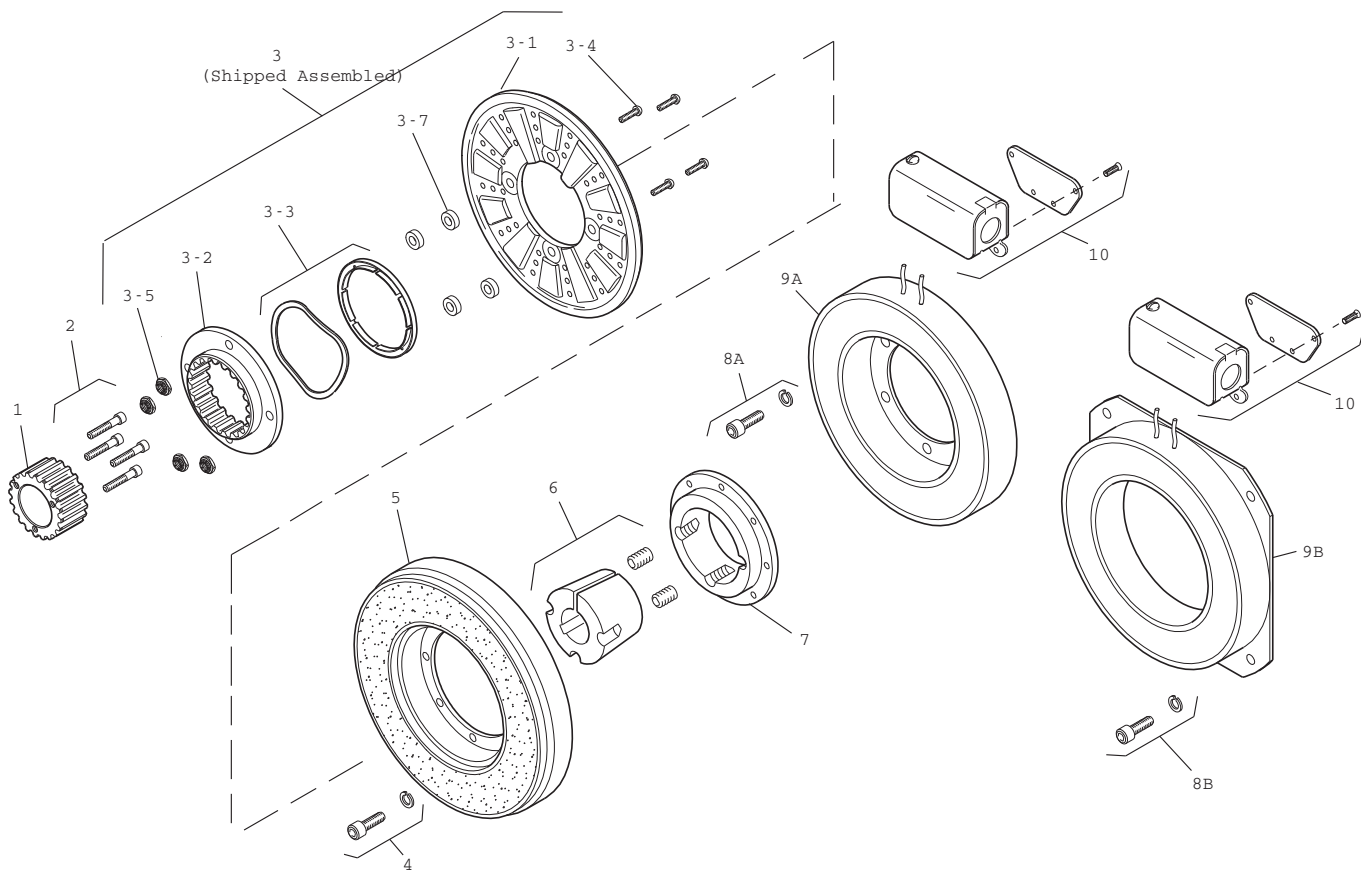

Item	Description	SF-1225, F.M. Part Number	Qty.
1	Splined Hub	540-0148	1
2	Mounting Accessory	5202-101-001	1
3	Armature & Splined Adapter	5203-111-001	1
3-1	Armature	5323-111-034	1
3-2	Splined Adapter	104-0010	1
3-3	Autogap Accessory	5323-101-002	1
3-4	Screw	797-0356	4
3-5	Locknut	661-0005	4
3-6	Retainer Plate		
3-7	Spacer	266-0004	4
4	Mounting Accessory	5321-101-002	1
5	Rotor		1
	Standard Friction Material	5203-751-001	
	†Optional LK Facing	5203-751-004	
6	Bushing, Taperlock*	180-0185 to 180-0217*	1
7	Rotor Hub	540-0318	1
8A	Mounting Accessory, I.M.	5321-101-001	1
8B	Mounting Accessory, O.M.	5321-101-002	2
9A	Field, Inside Mounted		1
	6 Volt	5203-451-002	
	24 Volt	5203-451-006	
	90 Volt	5203-451-005	
9B	Field, Outside Mounted		1
	6 Volt	5203-451-010	
	24 Volt	5203-451-013	

Item	Description	SF-1225, F.M. Part Number	Qty.
	90 Volt	5203-451-011	
10	Conduit Box	5200-101-012	1

*See page 48 for specific part numbers. †Optional LK facing available.

How to Order:

1. Specify Bore Size for Item 6.
2. Specify Voltage for Item 9A or 9B.
3. Specify Inside Mounted for Items 8A and 9A or Outside Mounted for Items 8B and 9B.

Example:

SF-1225 Clutch per I-25601 - 90 Volt, 1-1/2" Bore Inside Mounted

These units, when used in conjunction with the correct Warner Electric conduit box, meet the standards of UL508 and are listed under guide card #NMTR, file #59164. These units are CSA certified under file #LR11543

SF-1525 Clutch Flange Mounted—Heavy Duty

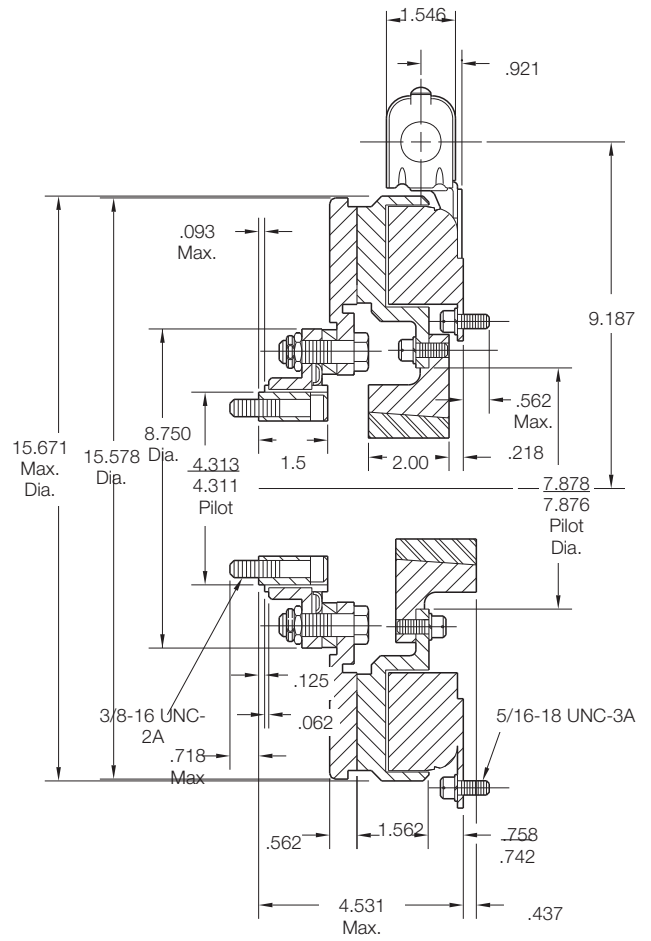
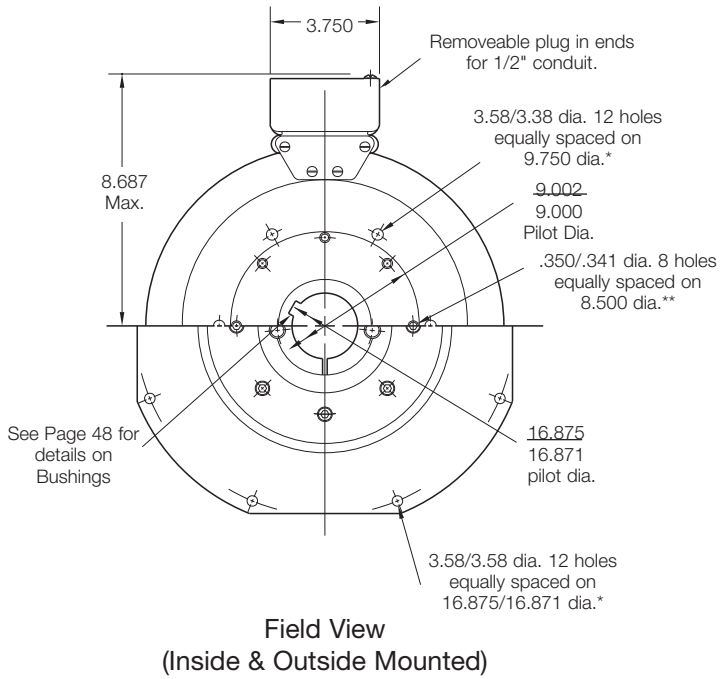
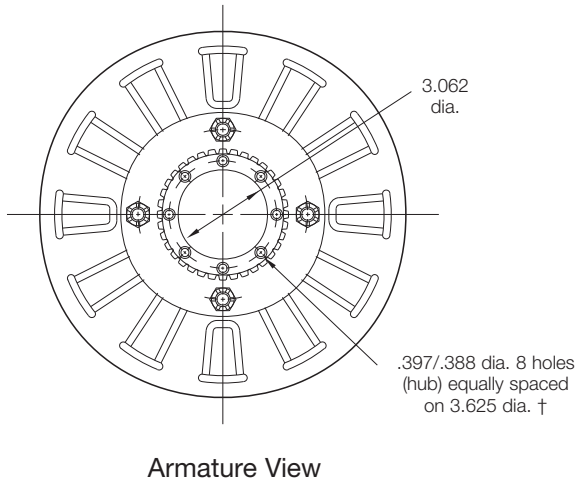

* Mounting holes are within .010 of true position relative to pilot diameter.

** Mounting holes are within .008 of true position relative to pilot diameter.

† Mounting holes are within .003 of true position relative to pilot diameter.

Customer Shall Maintain:

1. Concentricity of field mounting pilot dia. with rotor mounting shaft within .006 T.I.R.
2. Squareness of field mounting face with shaft within .006 T.I.R. measured at field mounting bolt circle.
3. Armature hub pilot diameter to be concentric with rotor mounting shaft within .010 T.I.R.

Shaft Size	.937 – 3.000
Static Torque	700 lb. ft.
Maximum Speed	2,000 rpm
Standard Voltage	D.C. 6, 24, 90

All dimensions are nominal unless otherwise noted.

SF-1525 Clutch Flange Mounted-Heavy Duty

Drawing I-25626

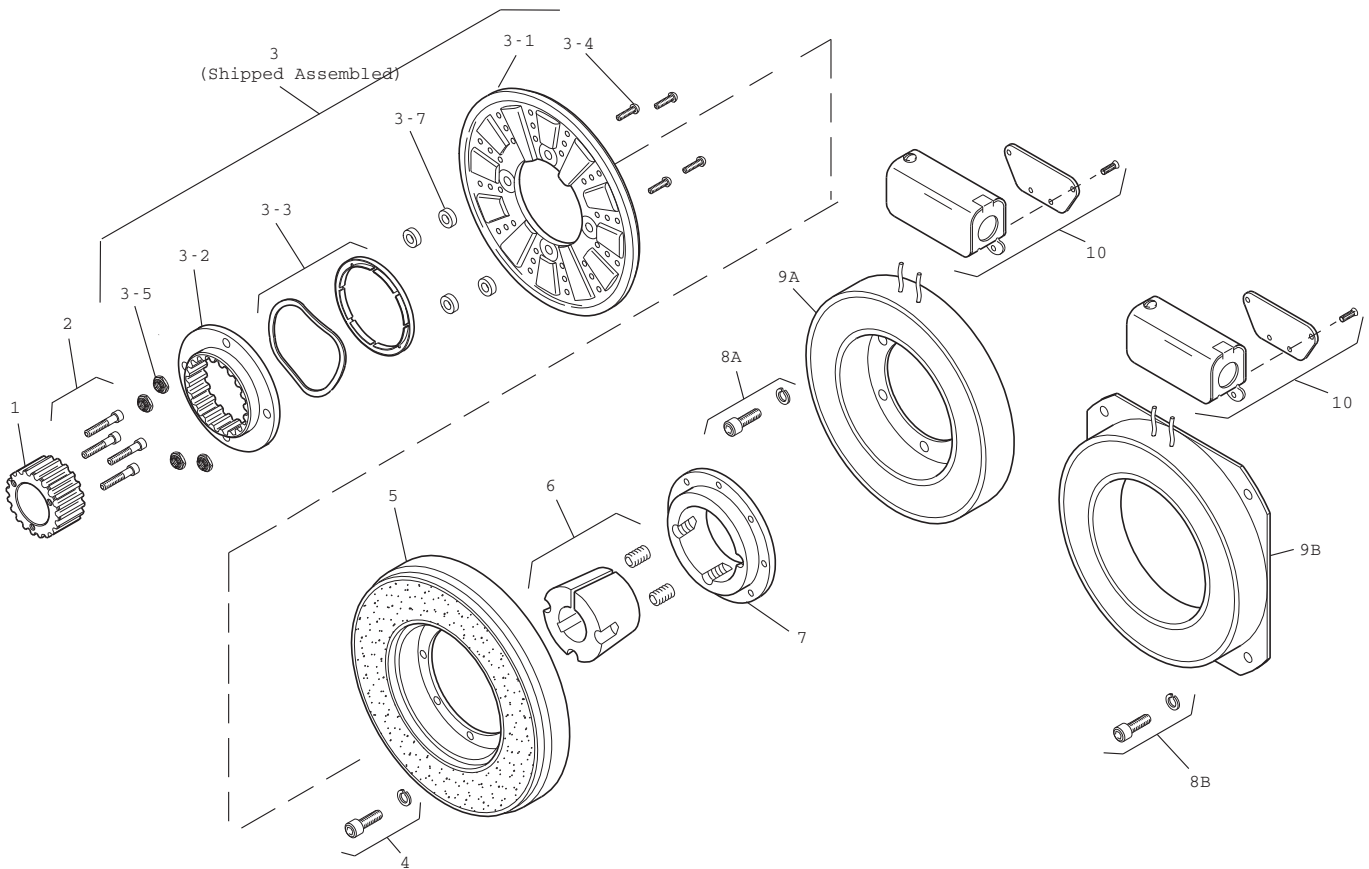

Item	Description	SF-1525, F.M. Part Number	Qty.
1	Splined Hub	540-0148	1
2	Mounting Accessory	5202-101-001	1
3	Armature & Splined Adapter	5204-111-004	1
3-1	Armature	5324-111-034	1
3-2	Splined Adapter	104-0011	1
3-3	Autogap Accessory	5323-101-002	1
3-4	Screw	797-0342	8
3-5	Locknut	661-0004	8
3-6	Retainer Plate	686-0003	1
3-7	Spacer	748-0333	8
4	Mounting Accessory	5321-101-002	2
5	Rotor		1
	Standard Friction Material	5204-751-002	
	†Optional LK Facing	5204-751-004	
6	Bushing, Taperlock*	1180-0223 to 180-0256*	1
7	Rotor Hub	540-0004	1
8A	Mounting Accessory, I.M.	5321-101-001	2
8B	Mounting Accessory, O.M.	5321-101-002	2
9A	Field, Inside Mounted		1
	6 Volt	5204-451-013	
	24 Volt	5204-451-015	
	90 Volt	5204-451-016	
9B	Field, Outside Mounted		1
	6 Volt	5204-451-055	
	24 Volt	5204-451-056	

Item	Description	SF-1525, F.M. Part Number	Qty.
	90 Volt	5204-451-057	
10	Conduit Box	5200-101-012	1

*See page 48 for specific part numbers. †Optional LK facing available.

How to Order:

1. Specify Bore Size for Item 6.
2. Specify Voltage for Item 9A or 9B.
3. Specify Inside Mounted for Items 8A and 9A or Outside Mounted for Items 8B and 9B.

Example:

SF-1525 Clutch per I-25626 - 90 Volt, 2" Bore Inside Mounted

These units, when used in conjunction with the correct Warner Electric conduit box, meet the standards of UL508 and are listed under guide card #NMTR, file #59164. These units are CSA certified under file #LR11543

Bushing Part Numbers Browning Bushing

Shaft Size	Keyway Size	Bushing Number		
		Warner Electric	Browning	
1/2	1/8 x 1/16	180-0002	H-1	
9/16	1/8 x 1/6	180-0003		
5/8	3/16 x 3/32	180-0004		
11/16	3/16 x 3/32	180-0005		
3/4	3/16 x 3/32	180-0006		
13/16	3/16 x 3/32	180-0007		
7/8	3/16 x 3/32	180-0008		
15/16	1/4 x 1/8	180-0009		
1	1/4 x 1/8	180-0010		
1-1/6	1/4 x 1/8	180-0011		
1-1/8	1/4 x 1/8	180-0012		
1-3/16	1/4 x 1/8	180-0013		
1-1/4	1/4 x 3/16	180-0014		
1-5/16	5/16 x 7/32	180-0015		
1-3/8	5/16 x 7/32	180-0016		
1-7/16	3/8 x 1/4	180-0017		H-2
1-1/2	3/8 x 7/32	180-0018		
3/4	1/2 x 3/8	180-0026	QI-1	
13/16	1/2 x 3/8	180-0027		
7/8	1/2 x 3/8	180-0028		
15/16	1/2 x 3/8	180-0029		
1	1/2 x 3/8	180-0030		
1-1/16	1/2 x 3/8	180-0031		
1-1/8	1/2 x 3/8	180-0032		
1-3/16	1/2 x 3/8	180-0033		
1-1/4	1/2 x 3/8	180-0034		
1-5/16	1/2 x 3/8	180-0035		
1-3/8	1/2 x 3/8	180-0036		
1-7/16	1/2 x 3/8	180-0037		
1-1/2	1/2 x 3/8	180-0038		
1-9/16	1/2 x 3/8	180-0039		
1-5/8	1/2 x 3/8	180-0040		
1-11/16	1/2 x 3/8	180-0041		
1-3/4	1/2 x 3/8	180-0042		
1-13/16	1/2 x 3/8	180-0043		
1-7/8	1/2 x 3/8	180-0044		
1-15/16	1/2 x 3/8	180-0045		
2	1/2 x 3/8	180-0046	QI-2	
2-1/16	1/2 x 3/8	180-0047		
2-1/8	1/2 x 3/4	180-0048		
2-3/16	1/2 x 23/32	180-0049		
2-1/4	1/2 x 11/16	180-0050		
2-5/16	5/8 x 5/16	180-0051		
2-3/8	5/8 x 5/16	180-0052		
2-7/16	5/8 x 5/16	180-0053		
2-1/2	5/8 x 5/16	180-0054		
2-9/16	5/8 x 5/16	180-0055		
2-5/8	5/8 x 5/16	180-0056		
2-11/16	5/8 x 5/16	180-0057		

Dodge Bushing

Shaft Size	Keyway Size	Bushing Number		
		Warner Electric	Dodge	
1/2	1/8 x 1/16	180-0101	1210	
9/16	1/8 x 1/16	180-0102		
5/8	3/16 x 3/32	180-0103		
11/16	3/16 x 3/32	180-0104		
3/4	3/16 x 3/32	180-0105		
13/16	3/16 x 3/32	180-0106		
7/8	3/16 x 3/32	180-0107		
5/16	1/4 x 1/8	180-0108		
1	1/4 x 1/8	180-0109		
1-1/16	1/4 x 1/8	180-0110		
1-1/8	1/4 x 1/8	180-0111		
1-3/16	1/4 x 1/8	180-0112		
1-1/4	1/4 x 1/8	180-0113		
1/2	1/8 x 1/16	180-0116		1215
9/16	1/8 x 1/16	180-0117		
5/8	3/16 x 3/32	180-0118		
11/16	3/16 x 3/32	180-0119		
3/4	3/16 x 3/32	180-0120		
13/16	3/16 x 3/32	180-0121		
7/8	3/16 x 3/32	180-0122		
15/16	1/4 x 1/8	180-0123		
1	1/4 x 1/8	180-0124		
1-1/16	1/4 x 1/8	180-0125		
1-1/8	1/4 x 1/8	180-0126		
1-3/16	1/4 x 1/8	180-0127		
1-1/4	1/4 x 1/8	180-0128		
1/2	1/8 x 1/16	180-0131	1615	
9/16	1/8 x 1/16	180-0132		
5/8	3/16 x 3/32	180-0133		
11/16	3/16 x 3/32	180-0134		
3/4	3/16 x 3/32	180-0135		
13/16	3/16 x 3/32	180-0136		
7/8	3/16 x 3/32	180-0137		
15/16	1/4 x 1/8	180-0138		
1	1/4 x 1/8	180-0139		
1-1/16	1/4 x 1/8	180-0140		
1-1/8	1/4 x 1/8	180-0141		
1-3/16	1/4 x 1/8	180-0142		
1-1/4	1/4 x 1/8	180-0143		
1-5/16	5/16 x 5/32	180-0144		
1-3/8	5/16 x 5/32	180-0145		
1-7/16	3/8 x 3/16	180-0146		
1-1/2	3/8 x 3/16	180-0147		
1-9/16	3/8 x 3/16	180-0148		
1-5/8	3/8 x 3/16	180-0149		
1/2	1/8 x 1/16	180-0155	2012	
9/16	1/8 x 1/16	180-0156		
5/8	3/16 x 3/32	180-0157		
11/16	3/16 x 3/32	180-0158		
3/4	3/16 x 3/32	180-0159		
13/16	3/16 x 3/32	180-0160		
7/8	3/16 x 3/32	180-0161		
15/16	1/4 x 1/8	180-0162		
1	1/4 x 1/8	180-0163		
1-1/16	1/4 x 1/8	180-0164		
1-1/8	1/4 x 1/8	180-0165		
1-3/16	1/4 x 1/8	180-0166		
1-1/4	1/4 x 1/8	180-0167		

Bushing Part Numbers

Dodge Bushing

Shaft Size	Keyway Size	Bushing Number		
		Warner Electric	Dodge	
1-5/16	5/16 x 5/32	180-0168	2012	
1-3/8	5/16 x 5/32	180-0169		
1-7/16	3/8 x 3/16	180-0170		
1-1/12	3/8 x 3/16	180-0171		
1-9/16	3/8 x 3/16	180-0172		
1-5/8	3/8 x 3/16	180-0173		
1-11/16	3/8 x 3/16	180-0174		
1-3/4	3/8 x 3/16	180-0175		
1-13/16	1/2 x 1/4	180-0176		
1-7/8	1/2 x 1/4	180-0177		
1-15/16	1/2 x 1/4	180-0178		
2	1/2 x 1/4	180-0179		
1/2	1/8 x 1/16	180-0185		2517
9/16	1/8 x 1/16	180-0186		
5/8	3/16 x 3/32	180-0187		
11/16	3/16 x 3/32	180-0188		
3/4	3/16 x 3/32	180-0189		
13/16	3/16 x 3/32	180-0190		
7/8	3/16 x 3/32	180-0191		
15/16	1/4 x 1/8	180-0192		
1	1/4 x 1/8	180-0193		
1-1/16	1/4 x 1/8	180-0194		
1-1/8	1/4 x 1/8	180-0195		
1-3/16	1/4 x 1/8	180-0196		
1-1/4	1/4 x 1/8	180-0197		
1-5/16	5/16 x 5/32	180-0198		
1-3/8	5/16 x 5/32	180-0199		
1-7/16	3/8 x 3/16	180-0200		
1-1/2	3/8 x 3/16	180-0201		
1-9/16	3/8 x 3/16	180-0202		
1-5/8	3/8 x 3/16	180-0203		
1-11/16	3/8 x 3/16	180-0204		
1-3/4	3/8 x 3/16	180-0205		
1-13/16	1/2 x 1/4	180-0206		
1-7/8	1/2 x 1/4	180-0207		
1-15/16	1/2 x 1/4	180-0208		
2	1/2 x 1/4	180-0209		
2-1/16	1/2 x 1/4	180-0210		
2-1/8	1/2 x 1/4	180-0211		
2-3/16	1/2 x 1/4	180-0212		
2-1/4	1/2 x 1/4	180-0213		
2-5/16	5/8 x 5/16	180-0214		
2-3/8	5/8 x 5/16	180-0215		
2-7/16	5/8 x 5/16	180-0216		
2-1/2	5/8 x 5/16	180-0217		
15/16	1/4 x 1/8	180-0223	3020	
1	1/4 x 1/8	180-0224		
1-1/16	1/4 x 1/8	180-0225		
1-1/8	1/4 x 1/8	180-0226		
1-3/16	1/4 x 1/8	180-0227		
1-1/4	1/4 x 1/8	180-0228		
1-5/16	5/16 x 5/32	180-0229		
1-3/8	5/16 x 5/32	180-0230		
1-7/16	3/8 x 3/16	180-0231		
1-1/2	3/8 x 3/16	180-0232		
1-9/16	3/8 x 3/16	180-0233		
1-5/8	3/8 x 3/16	180-0234		

Shaft Size	Keyway Size	Bushing Number		
		Warner Electric	Dodge	
1-11/16	3/8 x 3/16	180-0235	3020	
1-3/4	3/8 x 3/16	180-0236		
1-13/16	1/2 x 1/4	180-0237		
1-7/8	1/2 x 1/4	180-0238		
1-15/16	1/2 x 1/4	180-0239		
2	1/2 x 1/4	180-0240		
2-1/16	1/2 x 1/4	180-0241		
2-1/8	1/2 x 1/4	180-0242		
2-3/16	1/2 x 1/4	180-0243		
2-1/4	1/2 x 1/4	180-0244		
2-5/16	5/8 x 5/16	180-0245		
2-3/8	5/8 x 5/16	180-0246		
2-7/16	5/8 x 5/16	180-0247		
2-1/2	5/8 x 5/16	180-0248		
2-9/16	5/8 x 5/16	180-0249		
2-5/8	5/8 x 5/16	180-0250		
2-11/16	5/8 x 5/16	180-0251		
2-3/4	5/8 x 5/16	180-0252		
2-13/16	3/4 x 3/8	180-0253		
2-7/8	3/4 x 3/8	180-0254		
2-15/16	3/4 x 3/8	180-0255		
3	3/4 x 3/8	180-0256		
15/16	1/4 x 1/8	180-0262		3030
1	1/4 x 1/8	180-0263		
1-1/16	1/4 x 1/8	180-0264		
1-1/8	1/4 x 1/8	180-0265		
1-3/16	1/4 x 1/8	180-0266		
1-1/4	1/4 x 1/8	180-0267		
1-5/16	5/16 x 5/32	180-0268		
1-3/8	5/16 x 5/32	180-0269		
1-7/16	3/8 x 3/16	180-0270		
1-1/2	3/8 x 3/16	180-0271		
1-9/16	3/8 x 3/16	180-0272		
1-5/8	3/8 x 3/16	180-0273		
1-11/16	3/8 x 3/16	180-0274		
1-3/4	3/8 x 3/16	180-0275		
1-13/16	1/2 x 1/4	180-0276		
1-7/8	1/2 x 1/4	180-0277		
1-15/16	1/2 x 1/4	180-0278		
2	1/2 x 1/4	180-0279		
2-1/16	1/2 x 1/4	180-0280		
2-1/8	1/2 x 1/4	180-0281		
2-3/16	1/2 x 1/4	180-0282		
2-1/4	1/2 x 1/4	180-0283		
2-15/16	5/8 x 5/16	180-0284		
2-3/8	5/8 x 5/16	180-0285		
2-7/16	5/8 x 5/16	180-0286		
2-1/2	5/8 x 5/16	180-0287		
2-9/16	5/8 x 5/16	180-0288		
2-5/8	5/8 x 5/16	180-0289		
2-11/16	5/8 x 5/16	180-0290		
2-3/4	5/8 x 5/16	180-0291		
2-13/16	3/4 x 3/8	180-0292		
2-7/8	3/4 x 3/8	180-0293		
2-15/16	3/4 x 3/8	180-0294		
3	3/4 x 3/8	180-0295		

Bushing Part Numbers

Dodge Bushing

Shaft Size	Keyway Size	Bushing Number	
		Warner Electric	Dodge
1/2	1/8 x 1/16	180-0326	1610
9/16	1/8 x 1/16	180-0327	
5/8	3/16 x 3/32	180-0328	
11/16	3/16 x 3/32	180-0329	
3/4	3/16 x 3/32	180-0330	
13/16	3/16 x 3/32	180-0331	
7/8	3/16 x 3/32	180-0332	
15/16	1/4 x 1/8	180-0333	
1	1/4 x 1/8	180-0334	
1-1/16	1/4 x 1/8	180-0335	
1-1/8	1/4 x 1/8	180-0336	
1-3/16	1/4 x 1/8	180-0337	
1-1/4	1/4 x 1/8	180-0338	
1-5/16	5/16 x 5/32	180-0339	
1-3/8	5/16 x 5/32	180-0340	
1-7/16	3/8 x 3/16	180-0341	
1-1/2	3/8 x 3/16	180-0342	
1-9/16	3/8 x 3/16	180-0343	
1-5/8	3/8 x 3/16	180-0344	
1/2	1/8 x 1/16	180-0410	
9/16	1/18 x 1/16	180-0411	
5/8	3/16 x 3/32	180-0412	
11/16	3/16 x 3/32	180-0413	
3/4	3/16 x 3/32	180-0414	
13/16	3/16 x 3/32	180-0415	
7/8	3/16 x 3/32	180-0416	
15/16	1/4 x 1/16	180-0417	
1	1/4 x 1/16	180-0418	
1/2	1/8 x 1/16	180-0421	1310
9/16	1/8 x 1/16	180-0422	
5/8	3/16 x 3/32	180-0423	
11/16	3/16 x 3/32	180-0424	
3/4	3/16 x 3/32	180-0425	
13/16	3/16 x 3/32	180-0426	
7/8	3/16 x 3/32	180-0427	
15/16	1/4 x 1/16	180-0428	
1	1/4 x 1/16	180-0429	
1-1/16	1/4 x 1/8	180-0430	
1-1/8	1/4 x 1/8	180-0431	
1-3/16	1/4 x 1/8	180-0432	
1-1/4	1/4 x 1/8	180-0433	
1-5/16	15/16 x 5/32	180-0434	
1-3/8	15/16 x 5/32	180-0435	

Warranty

Warner Electric LLC warrants that it will repair or replace (whichever it deems advisable) any product manufactured and sold by it which proves to be defective in material or workmanship within a period of one (1) year from the date of original purchase for consumer, commercial or industrial use.

This warranty extends only to the original purchaser and is not transferable or assignable without Warner Electric LLC's prior consent.

Warranty service can be obtained in the U.S.A. by returning any defective product, transportation charges prepaid, to the appropriate Warner Electric LLC factory. Additional warranty information may be obtained by writing the Customer Satisfaction Department, Warner Electric LLC, 449 Gardner Street, South Beloit, Illinois 61080, or by calling 815-389-3771.

A purchase receipt or other proof of original purchase will be required before warranty service is rendered. If found defective under the terms of this warranty, repair or replacement will be made, without charge, together with a refund for transportation costs. If found not to be defective, you will be notified and, with your consent, the item will be repaired or replaced and returned to you at your expense.

This warranty covers normal use and does not cover damage or defect which results from alteration, accident, neglect, or improper installation, operation, or maintenance.

Some states do not allow limitation on how long an implied warranty lasts, so the above limitation may not apply to you.

Warner Electric LLC's obligation under this warranty is limited to the repair or replacement of the defective product and in no event shall Warner Electric LLC be liable for consequential, indirect, or incidental damages of any kind incurred by reason of the manufacture, sale or use of any defective product. Warner Electric LLC neither assumes nor authorizes any other person to give any other warranty or to assume any other obligation or liability on its behalf.

WITH RESPECT TO CONSUMER USE OF THE PRODUCT, ANY IMPLIED WARRANTIES WHICH THE CONSUMER MAY HAVE ARE LIMITED IN DURATION TO ONE YEAR FROM THE DATE OF ORIGINAL CONSUMER PURCHASE. WITH RESPECT TO COMMERCIAL AND INDUSTRIAL USES OF THE PRODUCT, THE FOREGOING WARRANTY IS IN LIEU OF AND EXCLUDES ALL OTHER WARRANTIES, WHETHER EXPRESSED OR IMPLIED BY OPERATION OF LAW OR OTHERWISE, INCLUDING, BUT NOT LIMITED TO, ANY IMPLIED WARRANTIES OF MERCHANTABILITY OR FITNESS.

Some states do not allow the exclusion or limitation of incidental or consequential damages, so the above limitation or exclusion may not apply to you. This warranty gives you specific legal rights and you may also have other rights which vary from state to state.

Changes in Dimensions and Specifications

All dimensions and specifications shown in Warner Electric catalogs are subject to change without notice. Weights do not include weight of boxing for shipment. Certified prints will be furnished without charge on request to Warner Electric.



Warner Electric LLC
31 Industrial Park Road • New Hartford, CT 06057
815-389-3771 • Fax: 815-389-2582
www.warnerelectric.com
An Altra Industrial Motion Company